



READ THIS MANUAL CAREFULLY!
It contains important safety information.
Keep it for future reference.

SYSTEM SIX

Owner's Manual Supplement

119914.PDF

CONTENTS

About This Supplement	2	Headset / Stem / Fork Info	8-9
Safety Messages	2	Si Bottom Bracket Info	10
Important Composite Message	3	Chainstay Protector	12
Intended Use (HP Road Bikes) ...	3	Rear Derailleur Hanger.....	13
Building Up A Frameset	4	Seat Post	14
Bike Stands	4	Geometry	15
Extreme Temperatures	4	Replacement Parts (Kits).....	16
Inspection & Crash Damage	4		
Repainting or Refinishing	5		
Serial Number.....	6		
Bottom Bracket Cable Guide	6		
Fork Star Nut Tool (KT014/)	7		

Please note that the specifications and information in this manual are subject to change for product improvement. For the latest product information, go to <http://www.cannondale.com/bikes/tech/>.

ABOUT THIS SUPPLEMENT

Cannondale Owner’s Manual Supplements provide important model specific safety, maintenance, and technical information. They are not replacements for your *Cannondale Bicycle Owner’s Manual*.

This supplement may be one of several for your bike. Be sure to obtain and read all of them.

If you need a manual or supplement, or have a question about your bike, please contact your Cannondale Dealer immediately, or call us at one of the telephone numbers listed on the back cover of this manual.

You can download Adobe Acrobat PDF versions of any Cannondale Owner’s Manuals or Supplements from our website: <http://www.cannondale.com/bikes/tech>.

- This manual is not a comprehensive safety or service manual for your bike.
- This manual does not include assembly instructions for your bike.
- All Cannondale bikes must be completely assembled and inspected for proper operation by a Cannondale Dealer before delivery to the owner.

**** Important ****

This manual may include procedures beyond the scope of general mechanical aptitude. Special tools, skills, and knowledge may be required.

If you have any doubt about your ability to properly inspect, adjust, or service your bicycle, do not attempt to perform the work described; please take it to a Cannondale Dealer.

SAFETY MESSAGES

In this manual, information which affects your safety is emphasized in the following ways:

 **WARNING**

A WARNING indicates a potentially hazardous situation which, if not avoided, can result in serious injury or death.

CAUTION

A CAUTION Indicates a potentially hazardous situation which, if not avoided, can result in serious damage to the product. The matters described under CAUTION may, if not avoided, lead to personal injury, or results depending on the situation and degree of damage. Important matters are described in CAUTION (as well as WARNING), so be sure to observe them.

A NOTE provides helpful information or tips intended to make the information presented clearer.

IMPORTANT COMPOSITES MESSAGE

Your bike is made from composite materials also known as “carbon fiber.”

All riders must understand a fundamental reality of composites. Composite materials constructed of carbon fibers are strong and light, but when crashed or overloaded, carbon fibers do not bend, they break.

For your safety, as you own and use the bike, you must follow proper service, maintenance, and inspection of all the composites (frame, stem, fork, handlebar, seat post, etc.) Ask your Cannondale Dealer for help.

We urge you to read PART II, Section D. “Inspect For Safety” in your Cannondale Bicycle Owner’s Manual BEFORE you ride.



**YOU CAN BE SEVERELY INJURED,
PARALYZED OR KILLED IN AN ACCIDENT
IF YOU IGNORE THIS MESSAGE.**

INTENDED USE

The intended use category for SystemSix bikes and framesets is High-Performance Road.

High-Performance Road

INTENDED to be ridden on paved roads only.

NOT INTENDED for off-road, cyclocross, or touring with racks or panniers.

TRADE OFF In a high-performance road bike, material use is optimized to deliver both light weight and specific performance. You must understand that these types of bikes are intended to give an aggressive racer or competitive cyclist a performance advantage over a relatively short product life. A less aggressive rider will enjoy longer frame life. Please understand your choice between light weight (shorter frame life) over more higher frame weight and a longer frame life. Please understand that you are choosing light weight over more dent resistant or rugged frames that weigh more. All frames that are very light need frequent inspection for cracks that would indicate that the frame is worn out from fatigue. These frames are likely to be damaged or broken in a crash. They are not designed to take abuse or be a rugged workhorse.



**USING YOUR BICYCLE IMPROPERLY IS
HAZARDOUS.**

BUILDING UP A FRAMESET

Before building up a frameset, consult with your Cannondale Dealer and the component manufacturers, and discuss your riding style, ability, weight, and interest in and patience for maintenance.

Make sure the components chosen are compatible with your bike and intended for your weight and riding style.

Generally speaking, lighter weight components have shorter lives. In selecting lightweight components, you are making a trade-off, favoring the higher performance that comes with less weight over longevity. If you choose more lightweight components, you must inspect them more frequently. If you are a heavier rider or have a rough, abusive or “go for it” riding style, buy heavy duty components.

Read and follow the component manufacturers warnings and instructions.

BIKE STANDS

The clamping jaws of an ordinary bike stand can generate a crushing force strong enough to seriously damage and ruin your bike frame.

CAUTION

Never place your bike in a bike stand by clamping the frame.

Place your bike in a stand by extending the seat post and positioning the stand clamp on the extended seat post. Don't extend beyond the MINIMUM INSERT line marked on the seat post.

Since your carbon seat post can also be damaged by clamping force, adjust the stand clamp for the minimum clamping force needed to secure the bike.

PROTECT FROM EXTREME TEMPERATURES

- Protect your bike from extreme temperatures when storing or transporting it.
- Allow your bike to cool off or warm up before you ride
- Do not store your bike in places where the temperature will exceed 66.5C° (150°F).

For example, do not leave your bike lying flat in a black pickup truck bed in the desert sun, or, under the glass of a hatchback auto.

INSPECTION & CRASH DAMAGE

WARNING

AFTER A CRASH OR IMPACT:

Inspect frame carefully for damage (See PART II, Section D. Inspect For Safety in your Cannondale Bicycle Owner's Manual.)

Do not ride your bike if you see any sign of damage, such as broken, splintered, or delaminated carbon fiber.

ANY OF THE FOLLOWING MAY INDICATE A DELAMINATION OR DAMAGE:

An unusual or strange feel to the frame

Carbon which has a soft feel or altered shape

Creaking or other unexplained noises,

Visible cracks, a white or milky color present in carbon fiber section

Continuing to ride a damaged frame increases the chances of frame failure, with the possibility of injury or death of the rider.

REPAINTING OR REFINISHING

You should not paint over the existing finish, refinish or repaint your bike. The carbon fiber composites making up the frame are held together by some extremely strong bonding chemicals. However, these bonds can be attacked or weakened by paint stripping or refinishing chemicals.

WARNING

Repainting, painting over, retouching, or refinishing your frame or fork can result in severe damage leading to an accident. You can be severely injured, paralyzed or killed.

Refinishing chemicals : Solvents, and strippers can attack, weaken, or destroy the important composite chemical bonds holding your frame together.

Using abrasives or sanding the frame/ fork structure, original paint, decals, or coatings through the use of mechanical actions such as plastic or glass bead blasting or other abrasive methods such as sanding or scraping can remove frame material or weaken it.

SERIAL NUMBER

The serial number for your bike is located on the underside of the bottom bracket shell on a printed and permanently affixed barcode label (shown arrow below).

Use this serial number for warranty registration and theft recovery. See your *Cannondale Bicycle Owner's Manual* for more information on warranty registration.

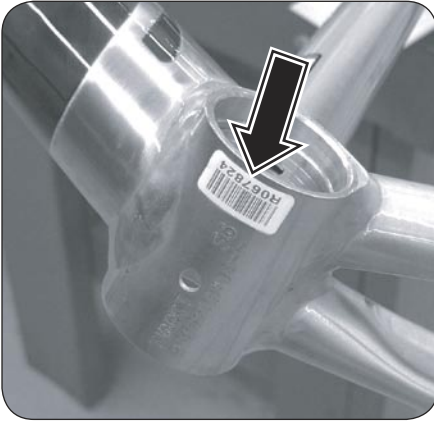

**BOTTOM BRACKET
CABLE GUIDE**

The snap in cable guide is mounted on the lower bottom bracket. Replacements are available through a Cannondale Dealer.

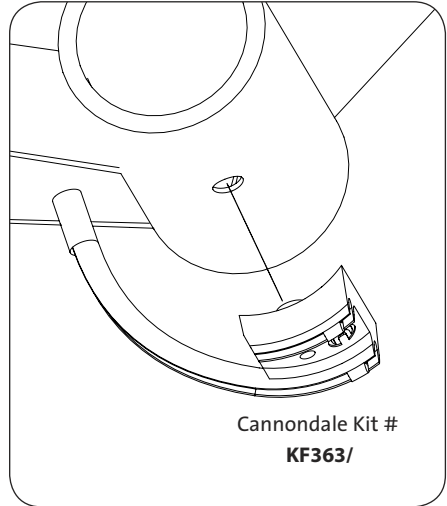

FORK STAR NUT TOOL

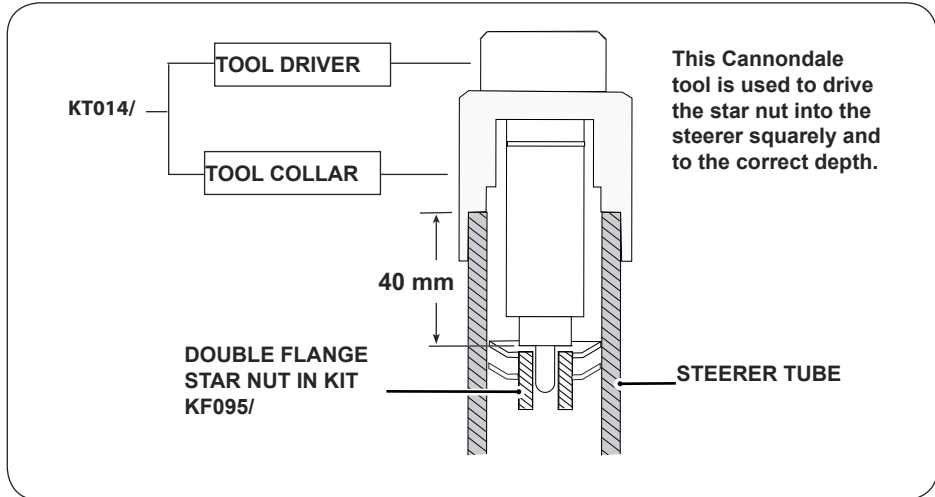

IMPORTANT

Use the Cannondale star nut tool - KT014/ to install the star nut into the fork.

MAKE SURE the star nut depth is 40mm.

DO NOT EXCEED the MAXIMUM STACK HEIGHT for the fork. Exceeding this height will place excessive stress on the steerer tube with risk of fork failure.

DO NOT INSTALL wedge compression or expansion devices. Use only the Cannondale kit KF095/. Headset compression devices do not extend far enough down into the steerer tube, and thus do not support the clamping force from the bottom stem bolt.

DO NOT INSERT spacers between the top of the stem and top cap.

Driving a star nut with the tool may produce marks on the inner steerer tube walls. This effect is normal. Occasionally, the marks inside the steerer tube can interfere with insertion of the top cap. Any burr or mark can be reduced by using a ball hone on a drill. This will remove the marks and open up the diameter enough to allow the top cap to easily slide inside the steerer. The ball hone will not cut structural carbon fibers, and will only remove the raised epoxy resin. The O.D. of the top cap must fit very snugly inside the I.D. of the steerer.

You Must Use a Torque Wrench

Stem clamp bolts, both for the steering tube and handlebars, must be torqued per the stem manufacturers specifications. Modern lightweight designs are permanently marked with proper torque specifications. These must be followed. Over tightening may cause damage and lead to a failure.

HEADSET, STEM, FORK

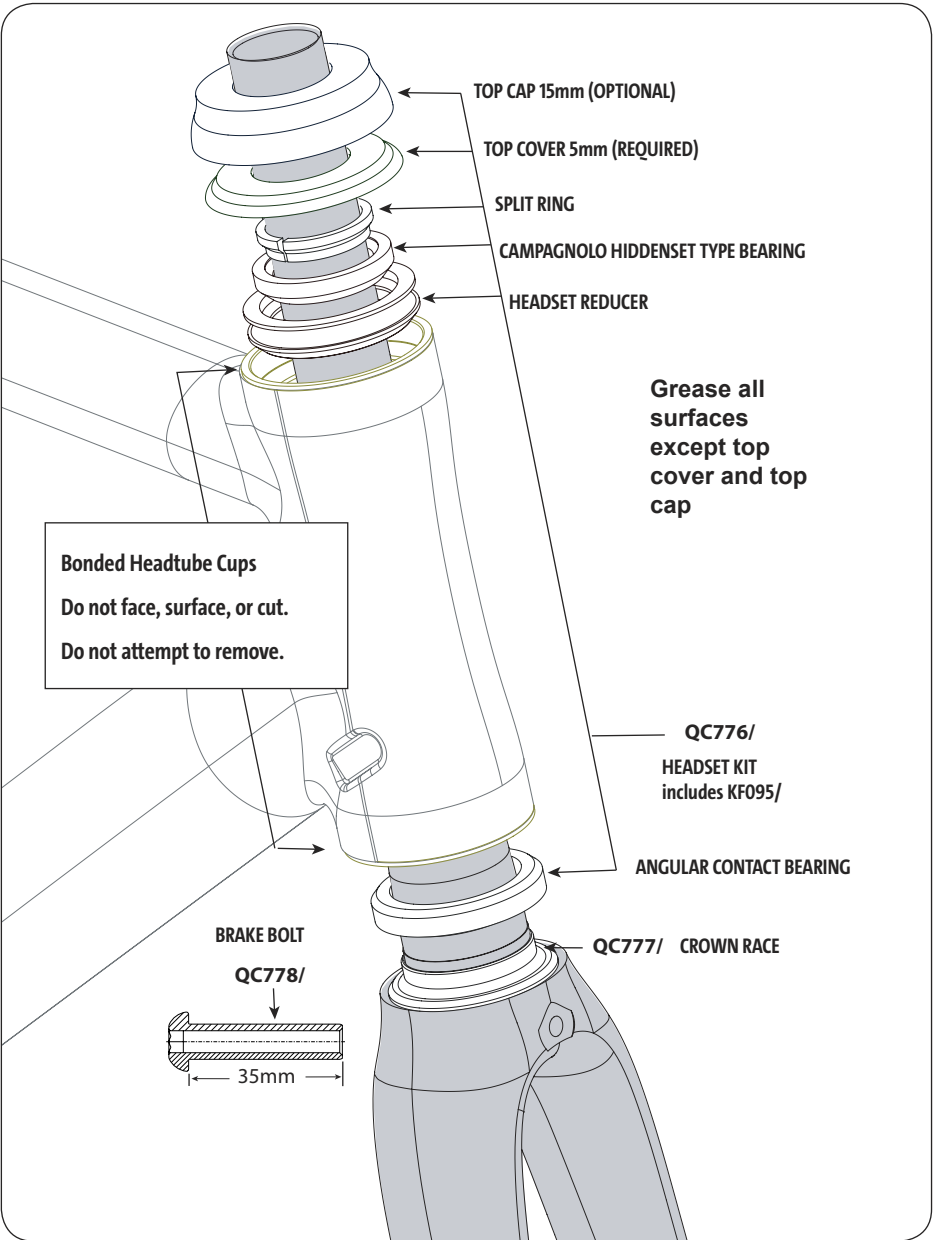

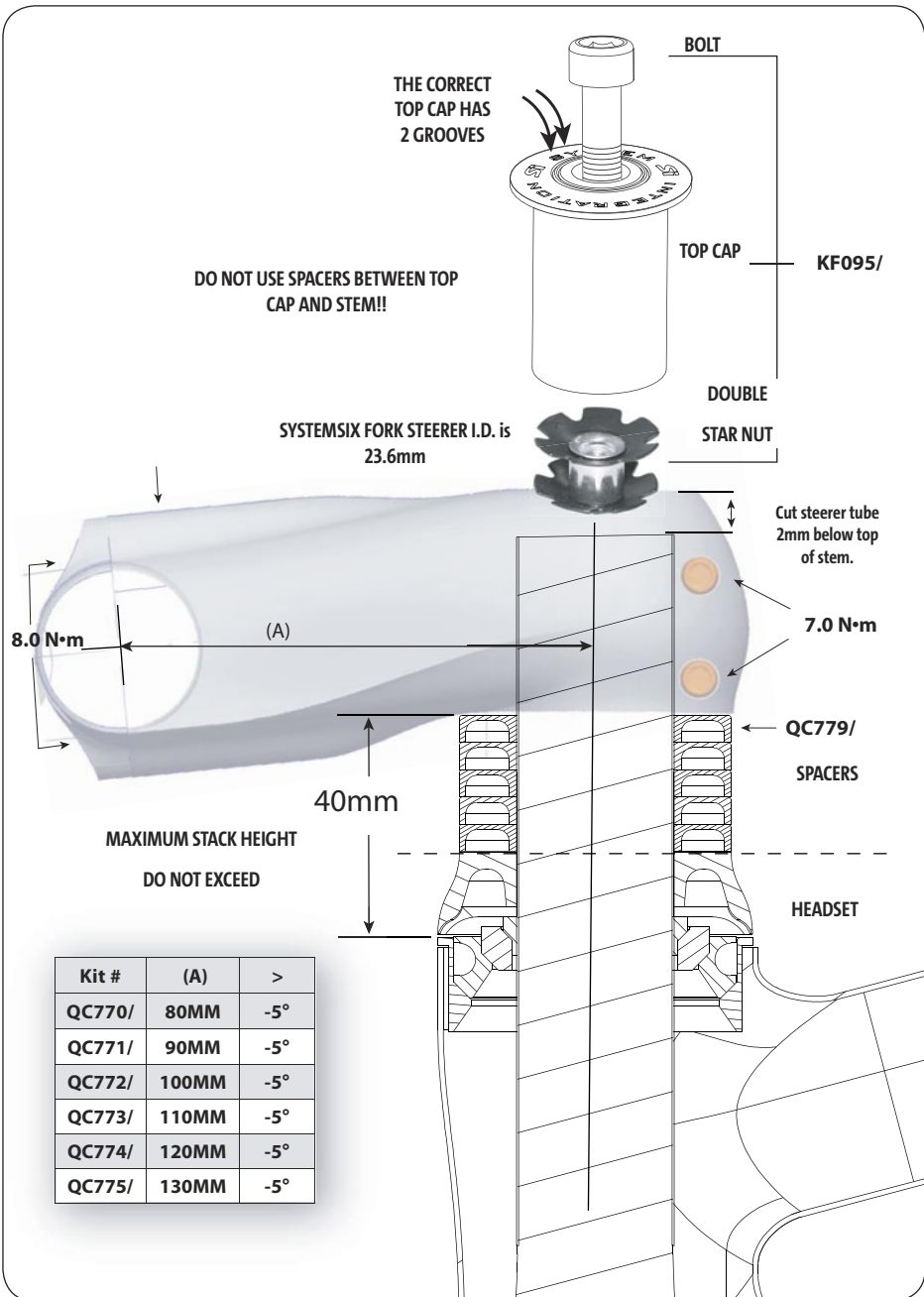

SI BOTTOM BRACKET SHELL INFORMATION

Bearings

The two bearings in the SI bottom bracket shell are a maintenance free sealed cartridge type and do not require lubrication. The bearings can be worn out overtime or damaged due to corrosion. The condition of the bearings should be inspected annually or anytime the crankset assembly is disassembled or serviced. Please consult the Si Cranksets Owner's Manual Supplement for specific information on servicing the Si crankset on your bike. It is available on our website: <http://www.cannondale.com/tech/>

Cannondale special tool **KT011/** is needed to remove the bearings. Replace bearings as a new set. Do not reinstall removed bearings.

Cannondale special tool **KT010/**, a press set for use with headset bearing press, is needed to install the bearings. The two circlips must be installed before the bearings.

It is not necessary to remove the circlips to service the bearings. Replacements are available if they become damaged. They can be lifted from the BB groove by lift the hooked end with a thin blade screwdriver.

Si-to-Standard BB Adapter

The SI bottom bracket adapter enables the use of standard English/68mm bottom bracket cranksets. The adapter is removable on alloy BB frames, however, repeated removal and reinstallation could result in damage to the SI BB shell and is not recommended. The adapter IS NOT a repair part and will only work in undamaged frames in good condition. Improper installation or removal can result in damage and void applicable frame warranty.

Cannondale Kit #	Description
KF365/	This kit includes the Si bottom bracket adapter and tools for use with a standard bicycle headset bearing press.
KF366/	This kit includes a two-piece adapter extraction tool for use with a standard bicycle headset bearing press.

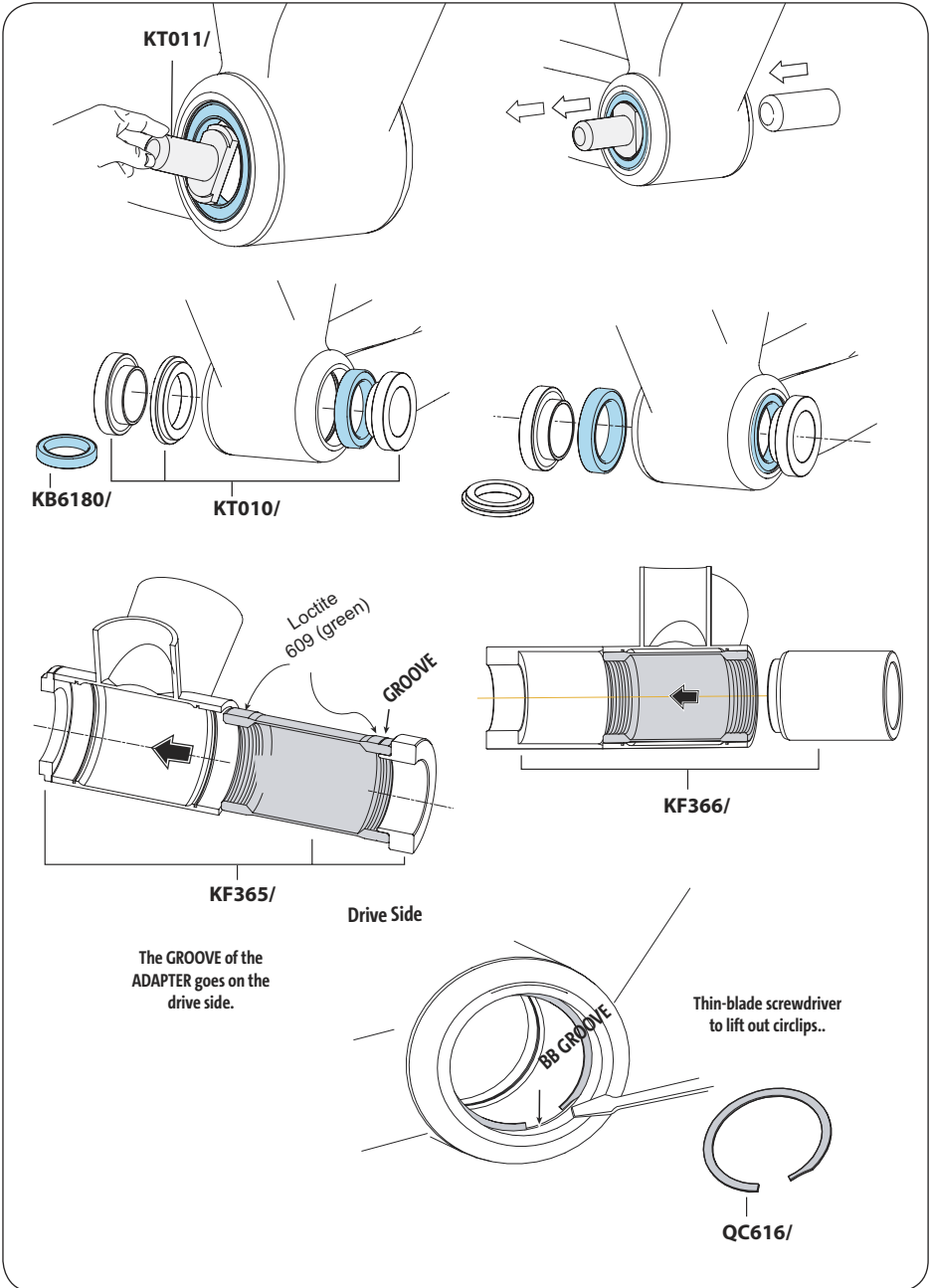

CHAINSTAY PROTECTOR

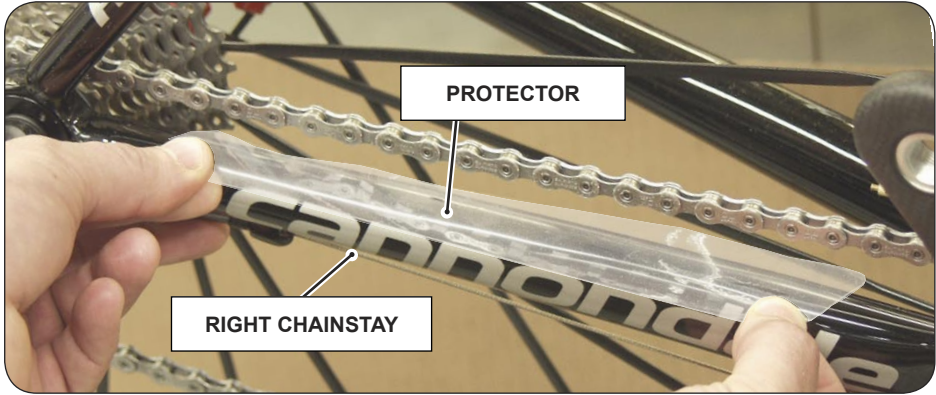

The clear chainstay protector provides limited protection against frame or finish damage caused by the chain. Replacement protectors are available through a Cannondale Dealer. On some bikes, the protector may overlay graphics. The protector will not damage the graphics if it is applied and removed properly. The protector is provided in a standard shape, but it can be trimmed easily with scissors if necessary.

To apply : Shift into largest front and smallest rear sprocket to indicate where chain is close to the chainstay. Clean the chainstay with a mild soap and water solution. Dry with a lint-free cloth. Apply the protector over the top of the chainstay Press firmly on long the entire length and edges of the protector to affix.

To remove: Carefully, lift an edge and peel away slowly!

CAUTION

Do not use a tool or sharp instruments to remove. Do not use solvents or other chemicals to clean .

REAR DERAILLEUR HANGER

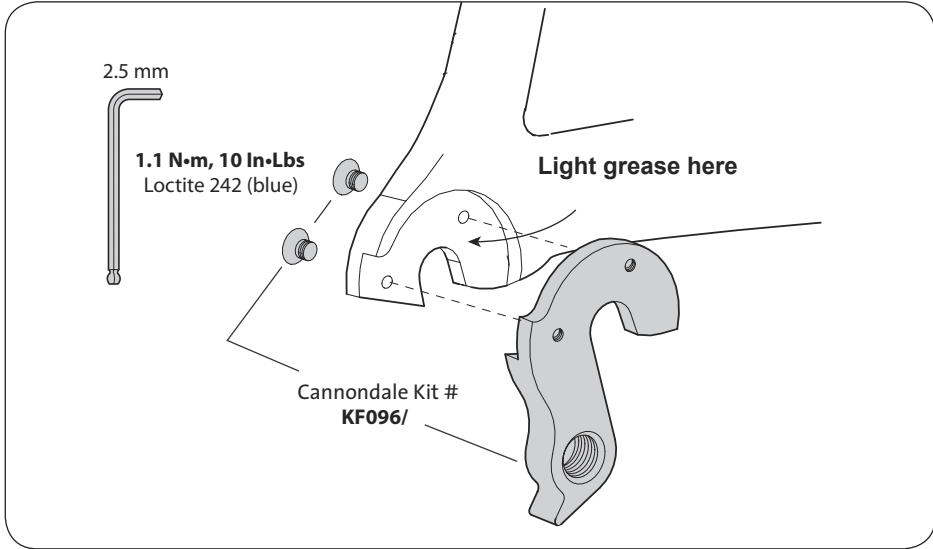

Before re- installing (same or new): Clean dropout and inspect carefully for any cracks or damage. Clean surfaces and apply a light film of bike grease to the dropout to minimize any noise or “creaking” that might result from very slight movement between the dropout and hanger during movement of the derailleur. Apply grease and Loctite carefully. Do not contaminate the male or female bolt threads with grease which would cause the Loctite to be ineffective.

Check derailleur adjustment after replacement.

Readjust wheel quick release so it is very tight. See PART I Section 4. A in your *Cannondale Bicycle Owner's Manual*.

CAUTION

DO NOT USE A DERAILLEUR HANGER ALIGNMENT TOOL TO STRAIGHTEN. Force applied can damage dropout.

SEAT POST

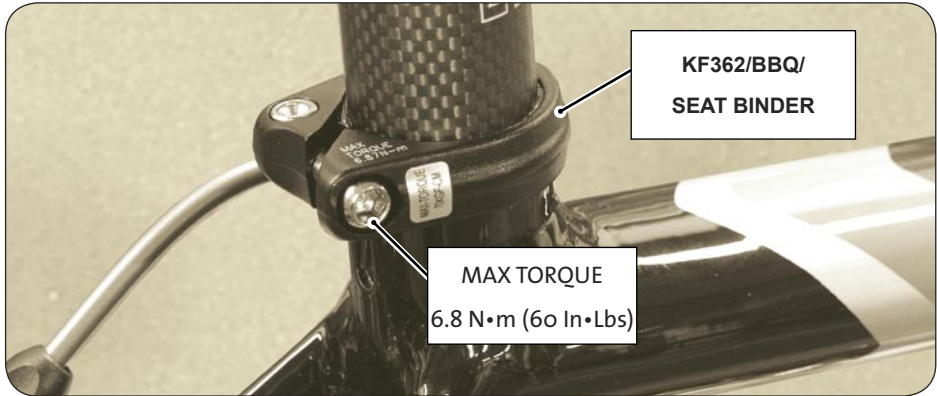

The entire seat tube section of your SystemSix frame is made from aluminium alloy.

You should follow the seat post manufacturer's recommendation for installation and maintenance of the seat post. It is very important that you follow the tightening torque recommendations for the seat post.

Whenever you adjust or remove the seat post:

- CLEAN AND APPLY A FILM OF GREASE TO THE INNER SURFACE OF THE BINDER CLAMP IN CONTACT WITH THE SEAT TUBE AND GREASE THE BINDER BOLT THREADS. This will promote even application of the clamping force.
- Make sure the inside of frame seat tube and the seat post itself is clean. Insert the post straight up and down in a smooth motion. Don't use a twisting or rotating action to install or remove the seat post. Cuts and scratches in the seat post can cause the seat post to break.
- Keep the MINIMUM INSERT or MAXIMUM HEIGHT line at or below the top edge of the seat tube.
- DO NOT CUT THE SEAT POST.
- AFTER ANY CRASH, FALL, OR IMPACT, remove and inspect the seat post for damage. If it is damaged in any way, (cracks, scratches, scrapes, gouges, splintering), discard it. Replace it with a new one.
- Under tightening the seat post (binder clamp or saddle adjustment) can result in it coming loose while riding causing you to lose control. Make sure the seat post is installed correctly and all fasteners tightened to the specified torque.

Note: Cannondale kit KF115/ KIT,GEL DYNAMIC CARBON SEATPOST gel will increase surface friction of carbon seat posts. The kit includes enough gel for several applications. Only a thin coating is needed. It is applied just like grease would be on an alloy seatpost.

GEOMETRY

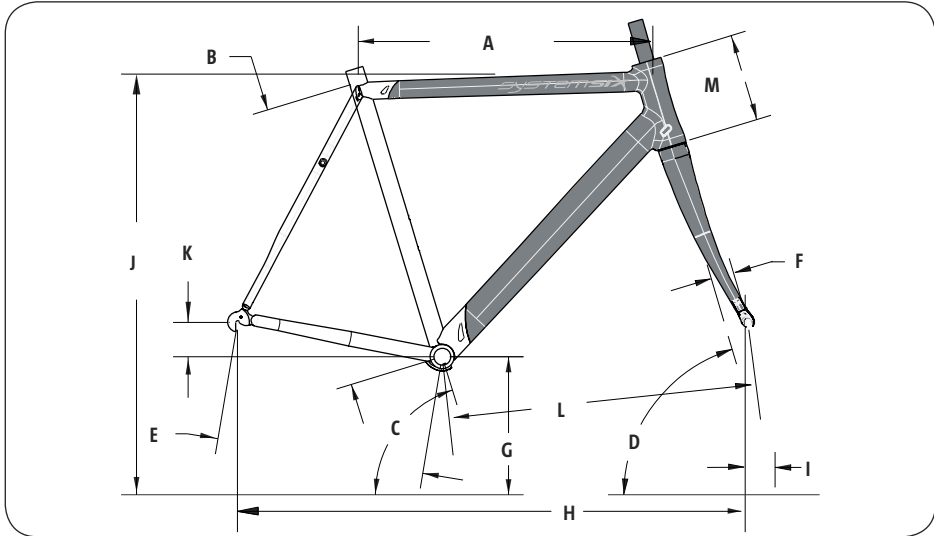

ITEM		48	50	52	54	56	58	60	63
Horizontal Top Tube Length (cm)	A	51.5	52.5	53.5	54.5	56.0	57.5	59.0	60.0
Measured Size (cm)*	B	46	48	50	52	54	56	58	61
Seat Tube Angle	C	74.5°	74.5°	74°	73.5°	73.5°	73°	72.5°	72°
Head Tube Angle	D	72°	72.5°	73°	73°	73°	73.5°	73.5°	73.5°
Chainstay Length	E	40.5	40.5	40.5	40.5	40.5	40.5	40.8	40.8
Fork Rake	F	4.5	4.5	4.5	4.5	4.5	4.5	4.5	4.5
Bottom Bracket Height (cm)	G	26.5	26.5	26.5	26.8	26.8	27.0	27.0	27.0
Wheelbase (cm)	H	95.9	96.6	96.8	97.5	99.2	99.6	100.1	101.3
Trail (cm)	I	6.2	5.9	5.6	5.6	5.6	5.3	5.3	5.3
Standover @ Top Tube Midpoint	J	74	75.3	76.5	78.5	80.1	82.2	83.8	86.6
Bottom Bracket Drop (cm)	K	7.2	7.2	7.2	6.9	6.9	6.7	6.7	6.7
Front Center Distance (cm)	L	56.5	57.2	57.4	58.0	59.7	60.1	61.0	61.4
Head Tube Length (cm)	M	11.0	11.5	12.0	14.0	15.5	17.5	19.0	22.0
STAR NUT DEPTH	40mm								
SEATPOST DIA.	31.6mm								
SEAT BINDER	Size				34.9mm				
	Maximum Torque				6.8 Nm				
FRONT DERAILLEUR CLAMP DIA.	34.9mm clamp-on								
DROPOUT SPACING	Rear 130mm, Front 100mm								
SYSTEMSIX STEM TORQUES	Stem Clamp Bolts				7.0 Nm				
	Handlebar Clamp Bolts				8.0 Nm				

* The measured size is from the center of the bottom bracket to the top of the top tube along the seat tube axis.
All sizes have a slightly sloping top tube.

REPLACEMENT PARTS (KITS)

ORDER	STEMS	NOTE
QC770/	SystemSix Stem 80mm	p. 9
QC771/	SystemSix Stem 90mm	p. 9
QC772/	SystemSix Stem 100mm	p. 9
QC773/	SystemSix Stem 110mm	p. 9
QC774/	SystemSix Stem 120mm	p. 9
QC775/	SystemSix Stem 130mm	p. 9
ORDER	HEADSET & FORK PARTS	NOTE
QC776/	Headset	p. 8
QC777/	Crown Race	p. 8
QC778/	Front Brake Bolt (35mm)	p. 8
QC779/	Headset Spacers	p. 9
QC780/	SystemSix Fork	p. 8
KF095/	Fork compression assembly	p. 9
KT014/	Cannondale Star Nut Installation Tool	p. 7
ORDER	OTHER SMALL PARTS	NOTE
KB6810/	Si Bottom Bracket Bearings (2x)	p. 11
QC616/	Si Bottom Bracket Circlips	p. 11
KF096/	Rear Derailleur Hanger CAAD8 style	p. 13
KF002/	Bottom Bracket Cable Guide (5x)	p. 6
KF055/	Adjuster-inline Shifter-2; Black,	--
KF362/BBQ	Seat Binder 34.9mm	p. 14
KF115/	Seatpost Gel for Carbon seatposts	p. 14
ORDER	SI BOTTOM BRACKET ADAPTER & TOOLS	NOTE
KF365/	Si Adapter w/ installation tool set	p. 11
KF366/	Si Adapter extraction tool set	p. 11

For an up to date list of kits available for your bike, please visit our Tech Center at : <http://www.cannondale.com/bikes/tech/>