



READ THIS SUPPLEMENT AND YOUR CANNONDALE BICYCLE OWNER'S MANUAL CAREFULLY! Both contain important safety information. Keep both for future reference.

# 2009 TANDEMS

## Owner's Manual Supplement 123598.PDF

### CONTENTS

SAFETY INFORMATION .....	2	TANDEM RIDING INFORMATION .....	6
Intended Use .....	2	MAINTENANCE .....	12
Building Up a Frameset .....	3	CANNONDALE KITS LIST .....	19
Tandem Specific Forks .....	3	GEOMETRY AND SPECIFICATION .....	20
Tandem Brakes .....	4		
Tandem Drum Brakes .....	4		



### WARNING

This supplement may include procedures beyond the scope of general mechanical aptitude. Special tools, skills, and knowledge may be required. Improper mechanical work increases the risk of an accident. Any bicycle accident has risk of serious injury, paralysis or death. To minimize risk we strongly recommend that owners always have mechanical work done by an authorized Cannondale retailer.

Please note that the specifications and information in this manual are subject to change for product improvement. For the latest product information, go to [http://www.cannondale.com/tech\\_center/](http://www.cannondale.com/tech_center/)

# SAFETY INFORMATION

## Intended Use

### ROAD TANDEM - CONDITION 1

Bikes designed for riding on a paved surface where the tires do not lose ground contact. Cannondale road tandems are designed for touring with racks and panniers. **Figure 1.**



### STREET TANDEM - CONDITION 2

Bikes designed for riding Condition 1, plus smooth gravel roads and improved trails with moderate grades where the tires do not lose ground contact. Cannondale street tandems are designed for touring with racks and panniers.

**Figure 2.**

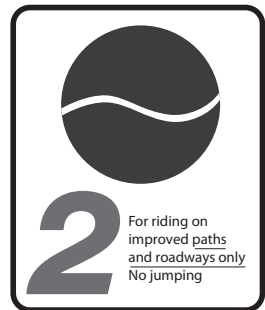

ROAD/ STREET TANDEM MAXIMUM WEIGHT LIMIT	RIDER	LUGGAGE	TOTAL
		500 lbs / 227 kg	75 lbs / 34 kg

**⚠ WARNING**

**UNDERSTAND YOUR BIKE AND ITS INTENDED USE. USING YOUR BIKE THE WRONG WAY IS DANGEROUS.**

Industry usage CONDITION 1 thru 5 are generalized and evolving. Consult your Cannondale Dealer about how you intend to use your bike.

Please read your [Cannondale Bicycle Owner's Manual](#) for more information about Intended Use and CONDITIONS 1 thru 5.

## Building Up A Frameset

Before building up a frameset, consult with your Cannondale Dealer and the component manufacturers, and discuss your riding style, ability, weight, and interest in and patience for maintenance.

Read and follow the component manufacturer's warnings and instructions.

### Tandem Specific Forks

The front fork of your Cannondale Tandem is specially designed to be much much stronger than a regular bike fork. One of the reasons it is much stronger is that braking a tandem subjects the frame and fork to tremendous stresses. Ordinary forks can buckle or fold under tandem braking conditions. Any fork used on your tandem must be designed and intended specifically for tandem use.



#### **WARNING**

**CONFIRM WITH ALL COMPONENT MANUFACTURER'S THAT THE COMPONENTS CHOSEN ARE DESIGNED AND INTENDED FOR USE ON A TANDEM BIKE AND INTENDED FOR YOUR WEIGHT AND RIDING STYLE.**

Tandems weight more and often are ridden faster than single bikes so many components must be designed for higher speeds and larger loads.

**BOTH RIDERS CAN BE SERIOUSLY INJURED, PARALYZED, OR KILLED. IN A RESULTING ACCIDENT IF YOU INGNORE THIS WARNING.**

## **Tandem Brakes**

Tandems can stop shorter than single bikes on pavement.

The reason: a single bike's braking performance is limited by the physics of pitching the rider over the front wheel. The tandem has the stoker's weight to hold the rear wheel down, so risk of pitchover is minimized.

The tandem's braking force on pavement is limited by the friction between the tire and the road. How great is that? It depends on the road and the tire, but it is very large. Since you don't want a front-wheel skid, don't be too bold. On good pavement, you can stop slightly more abruptly than you would on a single bike. Remember to gauge this by the feeling of deceleration, not by the brake hand lever effort. On poor pavement, unpaved surfaces, sand, oil, or any other debris, brake gingerly. Slow down—drastically—before you reach such surfaces.

Tandems, like singles, get most of their braking force from the front wheel. The rear wheel is more prone to skidding. The left hand lever normally controls the front brake. Apply front braking more than the rear brake for maximum stopping power. Brake before turns, not in them. If you must brake in a turn, do it with the rear brake.

Tandems are much faster than singles on downhills: GO SLOW and control your speed.

## **Tandem Drum Brakes**

Tandems bike frames are sometimes fitted with a rear drum brake (such as Arai). Rear drum brakes can be used as drag brakes to control speed such as on long downhill descents. Drum brakes are capable of dissipating heat without affecting other systems. A drum brake can be set up in addition to rim brakes.

Please consult with your Cannondale Dealer or shop to help you select and install a compatible drum brake system. Read and follow the brake manufacturer's instructions.

**WARNINGS****RIM BRAKE OVERHEATING HAZARD:**

Rim brakes used in normal conditions work fine. When used for long periods of continuous braking in mountainous terrain, rim brakes will heat the wheel rims. Heat build up in the rim can overheat the air in the inner tube, possibly resulting in a tire blowout. WHEN DESCENDING A LONG DOWNHILL, APPLY YOUR FRONT AND REAR BRAKES TOGETHER IN AN "ON AGAIN, OFF AGAIN" METHOD ALLOWING BRIEF PERIODS IN BETWEEN FOR THE BRAKE SYSTEM TO COOL. STOP, ENJOY THE VIEW and LET THE SYSTEM COOL.

**HYDRAULIC BRAKE OVERHEATING HAZARD :**

Hydraulic brakes used in normal conditions work fine. When used for long periods of continuous braking in mountainous terrain, hydraulic brakes will heat the hydraulic brake fluid. Heat build up in hydraulic brake fluid can cause brake fade possibly resulting in partial or complete loss of braking.

WHEN DESCENDING A LONG DOWNHILL, APPLY YOUR FRONT AND REAR BRAKES TOGETHER IN AN "ON AGAIN, OFF AGAIN" METHOD ALLOWING BRIEF PERIODS IN BETWEEN FOR THE BRAKE SYSTEM TO COOL. STOP, ENJOY THE VIEW and LET THE SYSTEM COOL.

**CLOSED HYDRAULIC BRAKE SYSTEMS:**

Closed hydraulic brake systems are not suitable for use with tandems. The brake fluid expansion in a closed hydraulic system can cause the brake pads to close, causing drag on the disc rotor and possible locking of the brakes in extreme conditions.

DO NOT USE A DISC BRAKE SYSTEM WHICH USES A "CLOSED" HYDRAULIC SYSTEM ON ANY TANDEM BICYCLE. Consult your authorized Cannondale retailer for advice about adding mechanical (non-hydraulic) or "open" system hydraulic disc brakes to your tandem.

**BRAKE MODIFICATIONS:**

Do not modify the frame or fork to install a brake system. Do not change forks. Do not use caliper mounting adapters or brackets. The incredible braking forces which can be produced by a disc brake, especially on the front wheel of a tandem, can bend or break a fork, frame, adapter or bracket which has not been designed and tested to withstand such a load. NEVER MODIFY YOUR TANDEM FRAME OR FORK TO INSTALL A BRAKE SYSTEM.

**YOU CAN BE SEVERELY INJURED, PARALYZED OR KILLED IF YOUR IGNORE THESE WARNINGS.**

## TANDEM RIDING INFORMATION



**Figure 3.**

Tandems are fun, and with two engines for the same frontal area, they're considerably faster than single bikes. Tandem teams learn to ride together well, to communicate without words, and to anticipate each other's desires. Tandeming is a great way to enjoy cycling with another person.

Tandems are serious business too. One rider (THE CAPTAIN) is entirely responsible for the well-being of the other rider (THE STOKER). The bike is bigger, heavier, and less forgiving of sloppy riding habits. A tandem captain can't be as spontaneous as a rider on a single, nor can the captain make the same kinds of last-minute recoveries from errors in judgment. Look farther ahead, plan farther ahead.

Also, be aware that tandems attract attention. People will stare, wave, shout. Passing cars, temporarily distracted, will often swerve in or out. The presence of a tandem can make people act differently on the road. A bell or airhorn can be very handy in traffic.

**WARNING**

**TANDEM ARE BIGGER, HEAVIER, AND LESS MANEUVERABLE THAN SINGLE RIDER BIKES.**

- Ride very cautiously as your team climbs the tandem learning curve.
- More time is needed to react and avoid ride hazards.
- Always think further ahead. Allow more time. Learn to anticipate hazards.

Tandem riding, like any bicycle riding carries a risk of serious injury, paralysis or death.

## The Captain's Responsibility

The captain's primary job is to make the stoker happy. With an unhappy stoker, the captain won't have a riding partner! So you must reassure your partner with careful, methodical riding habits. Anticipate maneuvers, beginning them far in advance. Be alert to shifting needs. A too-fast or too-slow cadence is doubly annoying to the stoker because she/he can't fix it. Watch the road or trail ahead, and make your steering and braking corrections smoothly.

Ride slightly farther from the curb, or from parked cars, than you would on a single bike. Your stoker doesn't want to feel hemmed in. If you ride too far to the right, you may find your stoker leaning to the left, trying to veer away from the curb.

When you conduct a maneuver, such as merging across traffic to make a left turn or steering around a pothole, make your decision early. Signal your intentions clearly, proceed on a straight path, and complete the maneuver. A decisive captain will ride smoother, and that will make the stoker happier.

Most new tandemists find captaining exhausting, and they get sore shoulder muscles from being tense. This too will pass. As you become accustomed to the requirements of captaining a tandem, you'll develop a light touch.

Don't hot dog. If your stoker is nervous, ride slowly. In time, the stoker may become more confident and ask for more speed. But if she/he wants to go slow, go slow! The more conservative voice must prevail. That's only fair. Remember, you're the chauffeur, not the stunt pilot.

## **The Stoker : The Best Seat in The House**

The back seat on a tandem is the fun seat. You have this person in front of you who's giving all his/her attention to making you feel comfortable. The view is terrific out to the sides, just like on a train ride. The view to the front may be a bit bland, but the captain's jersey pockets are a great place to put your fruit bars, and other hedonistic goodies.

Your obligations are few: Pedal—at an agreed-upon effort level. Pedal smoothly, so your pedaling doesn't make your upper body move around. Don't shift your upper body weight abruptly. (Your weight shift can inadvertently steer the bike, and force the captain to fight you.) Hold your head high and enjoy the scenery. Tell your captain what she/he is missing while she/he keeps eyes glued to the road for potholes.

Many tandem teams delegate hand turning signals to the stoker. This not only encourages communication between the stoker and the captain, it also allows the captain to concentrate on the steering and braking involved in making the maneuver.

Every successful stoker learns to delegate authority. The captain steers. The captain decides when to pedal and when to coast. When coasting, the captain decides where to position the pedals. Never fight the captain on these matters. She/he is busy giving you a great ride so you can enjoy yourself.

## **Tandem Bike Fit**

In addition to sizing and comfort issues for each individual, the bicycle must be made to accommodate the interaction between the two riders. This document is meant to offer hints and suggestions but only scratches the surface of tandem setup. The best configuration for any pair of cyclists on a tandem will be the result of experimentation. You should investigate the pros and cons of any setup decisions by first consulting with people or publications which are knowledgeable about tandem bicycles. See page 11.

The captain should fit the tandem as she/he would fit on a single bike. But on a tandem, it's doubly important to have 2-3 inches of crotch clearance for the starting and stopping maneuvers described below.

The stoker uses the same seat-to-pedals distance as on a single bike. But the handlebars will be closer (which is okay, since the stoker doesn't need to steer).



---

## Getting Underway

Allow time for a complete pre-ride inspection. See your *Cannondale Bicycle Owner's Manual* for overall bicycle pre-ride checks. See the Maintenance section of this supplement for Tandem checks.

## Starting Off

Starting and stopping a tandem is smooth and easy, but only if you do everything in the exact prescribed order. Start by shifting the bike into a comfortably low gear.

The captain mounts first. Before, and only before anyone gets on the bike, it can be leaned over to lower the clearance to straddle the bike. Swing your leg forward over the handlebars, not back over the rear of the bike. There might be a person standing there! Straddle the top tube, plant your feet on the ground, and spread your legs to clear the pedals. Firmly hold the bike upright and squeeze both brakes.

Never let the bike lean to the side, particularly after the stoker gets on. This is the biggest difference between your tandem and your single. (Your single is so light that you don't think twice about leaning it. The tandem is not only heavy, it's top heavy. Once you let it lean a little, the stoker's weight makes it want to lean more. And the stoker just hates the way that feels.)

The stoker gets on now. Because the captain is holding the bike rock solid, the stoker can mount it like a horse. Put one foot on a pedal and swing your other leg rearward over the saddle. Now the stoker puts both feet in the toe clips or clipless pedals. When you're ready, the stoker backpedals so the captain's preferred starting pedal is in the up position. The stoker says, "ready."

Now the captain can start. Pick up one foot, put it on a pedal, and stand on it while steering straight ahead. (Don't put your rear end on the seat before starting to pedal, because that could make the bike lean over and wobble, and possibly fall.) After you've started the first pedal stroke, get in the saddle, put your other foot on the backside of the pedal, and continue pedaling and steering. Don't worry about the toe clip or clipless pedals. Let the toe clip scrape the ground. Pedal until you are going comfortably fast (10 mph or so), and then put your other foot in the toe clip or clipless pedals.

## Stopping

If you stop briefly, say, for a traffic light, the captain stops the bike while the stoker stays strapped in. The captain takes one foot off the pedal, dismounts from the seat, and puts the foot on the ground while holding the bike absolutely upright. Starting up again is just like your initial start-up. The captain should let the stoker know what's happening —talk to one another —no surprises.

To stop and dismount, reverse the mounting procedure. The captain gets off the seat, spreads legs to clear the pedals and brace the bike upright while the stoker climbs off. Then the captain can dismount.

## Slow Speed Riding

Tandems are stable and easy to maneuver at slow speeds. But they need a confident captain who doesn't overcorrect or induce wobbling. A smooth style is the key to good slow-speed riding. After you've gotten to know your tandem well, you'll find you can make a U-turn on a narrow two-lane road.

## Communication

Some tandem teams talk a lot about riding. They inform each other of every bump, every shift, every time they slow down, every drink from a water bottle. Others almost never talk. They prefer to communicate silently. Whichever style you pick is up to you. Just pick the one that works for you.

One important coordination activity may require talking, at least at first: shifting. The reason: on a single bike, riders intuitively let up on the pedals when they're shifting. On a tandem, the stoker doesn't necessarily do that. This is hard on derailleurs (especially front derailleurs) and may make shifts more difficult. Make sure you both let up on the pedals during critical shifts. Whether you do that by talking or by the stoker feeling when captain is about to shift is up to you.



### WARNING

**GOOD COMMUNICATION BETWEEN THE CAPTAIN AND STOKER INCREASES THE SAFETY AND ENJOYMENT OF THE RIDE. MIS-COMMUNICATION OR POOR COORDINATION INCREASES THE CHANCE OF BEING INVOLVED IN AN ACCIDENT.**

#### **NEW TANDEM RIDERS:**

Before riding on a more challenging course, choose an open area free of hazards to practice and develop good Tandem communication skills.

## Riding at Night

Most of tandem safety comes from good technique, which we've described above. A few specific warnings merit mention, though.

Riding a tandem at night is legal if you have a headlight and taillight— but we don't recommend it. Nighttime riding is more mentally demanding than day time riding. Tandem riding is more mentally demanding than single riding. A tandem at night adds up to too much demand, and too small a margin for error. A tandem is a pleasure vehicle, so use it during day—the most pleasant time to ride.

See your Cannondale Bicycle Owner's Manual for more important safety information on riding at night.

## Further Reading & Information:

This supplement can't cover everything you might want to know about tandeming. For additional information on riding technique, we suggest you contact:

- Talk to an Authorized Cannondale Dealer with Tandem expertise.
- Tandem Club of America, c/o Jack & Susan Goertz, 2220 Vanessa Dr., Birmingham, AL 35242, 205-991-7766, e-mail: [tca\\_of\\_a@mindspring.com](mailto:tca_of_a@mindspring.com). Their magazine, Doubletalk, and attendance at TCA events will make you an expert. Besides, TCA events, such as the various regional tandem rallies, are lots of fun.
- Local tandeming/bicycling clubs in your area have many helpful people. Ask your Authorized Cannondale retailer to put you in touch with them.
- The Tandem Scoop, the only book about tandeming we know of, contains extensive instructions on smooth technique, racing, touring, and dirt riding, riding with children, blind and disabled stokers, and other subjects. (By John Schubert, published by Burley Designs, Eugene, Oregon, 1996. Paperback, \$9. ISBN 0-9637190-0-9)
- The Tandem Book, The Complete Guide to Buying, Riding and Enjoying Tandem Bicycles. (By Angel Rodriguez and Carla Black, \$14.95, available from Adventure Cycling, 800-721-8719 8am.-5pm. M-F Mtn. Time, or [www.adv-cycling.org](http://www.adv-cycling.org))

## MAINTENANCE

The following table lists only supplemental maintenance items. Please consult your Cannondale Bicycle Owner's Manual for more information on basic bike maintenance. Consult with your Cannondale Dealer to create a complete maintenance program for your riding style, components, and conditions of use. Follow the maintenance recommendations given by the component manufacturers for the various non-Cannondale parts of your bike.

WHAT TO DO	HOW OFTEN
<p><b>CHECK CHAINS, DERAILLEURS, HEADSETS AND TIRES</b> on Tandems experience greater wear and tear than on single bikes. These items should be maintained as on your single bike, but more frequently and more carefully.</p>	<p><b>BEFORE AND AFTER EACH RIDE</b></p>
<p><b>CHECK THE STOKER HANDLEBAR SYSTEM.</b> See page 13.</p>	
<p><b>TANDEM TIRE PRESSURE</b> is critical. Low tire pressure invites pinch-cut flats, while high pressure improves your performance and makes the tires last longer. Use the maximum pressure named on the tire sidewall.</p>	<p><b>BEFORE EVERY RIDE</b></p>
<p><b>CHECK CONTROL CABLES</b> are critical. Because of their length on tandems, cables are vulnerable to poor performance friction or poor routing. Have damaged (worn, frayed, stretched, broken) cables replaced with new ones before riding.</p>	<p><b>EVERY FEW RIDES</b></p>
<p><b>CHECK THE TIMING CHAIN TENSION</b> - The timing chain—between the two cranksets—is unique to tandems. It stretches in normal use, and must be kept tight. A loose timing chain can flop sideways and snag a crank arm, or it can come off entirely. See pages 14.</p> <p>Buy a chain wear indicator to know when to replace both chains. A tandem has a lot of expensive chainwheels and cogs, so the chain wear indicator will quickly pay for itself.</p>	



### WARNING

**ANY PART OF A POORLY MAINTAINED BIKE CAN BREAK OR MALFUNCTION LEADING TO AN ACCIDENT WHERE YOU CAN BE KILLED, SEVERELY INJURED OR PARALYZED.**

Please ask your Cannondale Dealer to help you develop a complete maintenance program, a program which includes a list of the parts on your bike for YOU to check regularly. Frequent checks are necessary to identify the problems that can lead to an accident.

## Checking the Stoker Handlebar System

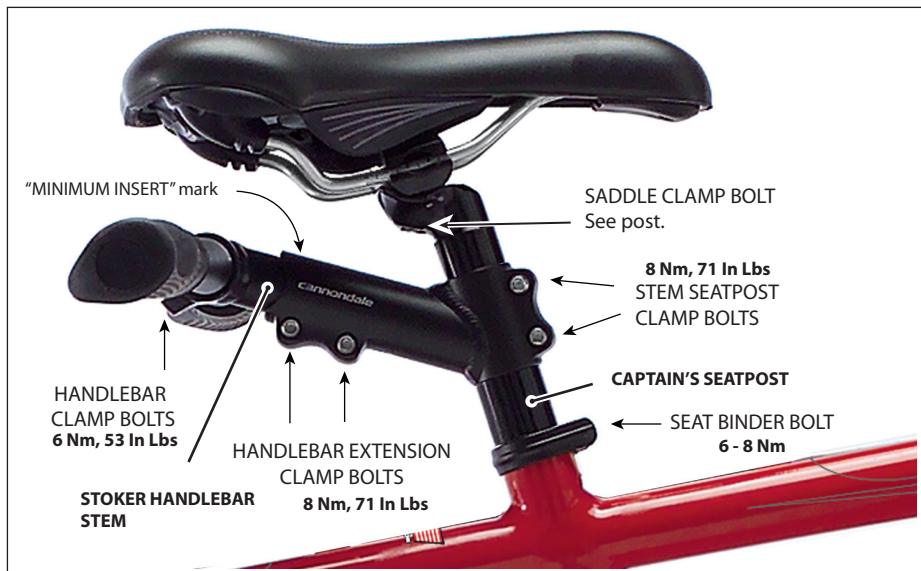

Figure 4.

### WARNING

**TO PREVENT THE STOKER HANDLEBAR SYSTEM DETACHING, MOVING, ROTATING, OR TWISTING UNEXPECTEDLY OR SUDDENLY WHILE RIDING :**

**BEFORE EACH RIDE:** Check all bolts. Use a torque wrench when tightening the bolts of the stoker/captain seat post and handlebar assemblies. Follow the manufacturer’s torque instructions for your particular handlebar/stem/seat post components.

**AT LEAST ANNUALLY:** Remove, clean and inspect the captains seat post. Replace it with a new one if it is damaged. Also, clean and inspect the Stoker’s handlebar assembly. Make sure it is in good condition. Replace it with a new one if it is damaged.

**EXTENSION:** If the stoker handlebar assembly is the extension type, never extended it beyond the “MINIMUM INSERT” or MAXIMUM EXTENSION” line.

If you do not understand these instructions or are unable to complete them as described, please have the performed by a professional bike mechanic.

**BOTH RIDERS CAN BE SERIOUSLY INJURED, PARALYZED, OR KILLED. IN A RESULTING ACCIDENT IF YOU IGNORE THIS WARNING.**

## Adjusting The Timing Chain Tension

Periodically, the tension of the timing chain must be checked. The tension should be maintained at 1/2" of total vertical deflection. Wear and stretch will cause the tension to change over time.

1. Clean and lubricate the timing chain.
2. **MEASURE THE TENSION** - On the upper length of the chain in the middle of the front and rear timing chainrings, move the chain up and down. You should be able to lift it up 1/4" and move it down 1/4." This is 1/2" vertical deflection.

Turn the crank to rotate the wheel so you can check the chain tension at different links of the chain at the same midpoint. If the chain seems tighter in some places, it may be an indication of chain damage or some other problem. Have the chain replaced or the damage repaired before attempting any adjustment. If the chain is in good condition continue to step 3.

3. **ADJUST THE TENSION** - Insert a 4 mm Allen key into the eccentric fixing bolt and turn it counter-clockwise to loosen the eccentric. After the first turn or so, the wedge bolt will feel loose then it may seem to tighten as it pushes the wedge backward freeing up the eccentric to rotate in the BB shell. When the wedge is loose and the eccentric assembly is free to rotate within the bottom bracket shell, insert the end of an Allen key into one of the eccentric holes and rotate it until the correct vertical chain deflection is reached. See next figure.
4. **RETIGHTEN THE FIXING BOLT** - When the chain tension is set, tighten the wedge bolt to the specified torque.



### WARNING

#### **INCORRECT CHAIN TENSION ADJUSTMENT CAN CAUSE YOU TO HAVE AN ACCIDENT.**

A chain that is too loose can come off and a chain that is too tight can bind, break or accelerate wear on other parts. Both conditions can lead to an accident.

If you do not understand these instructions or are unable to complete them as described, please have them performed by a professional bike mechanic.

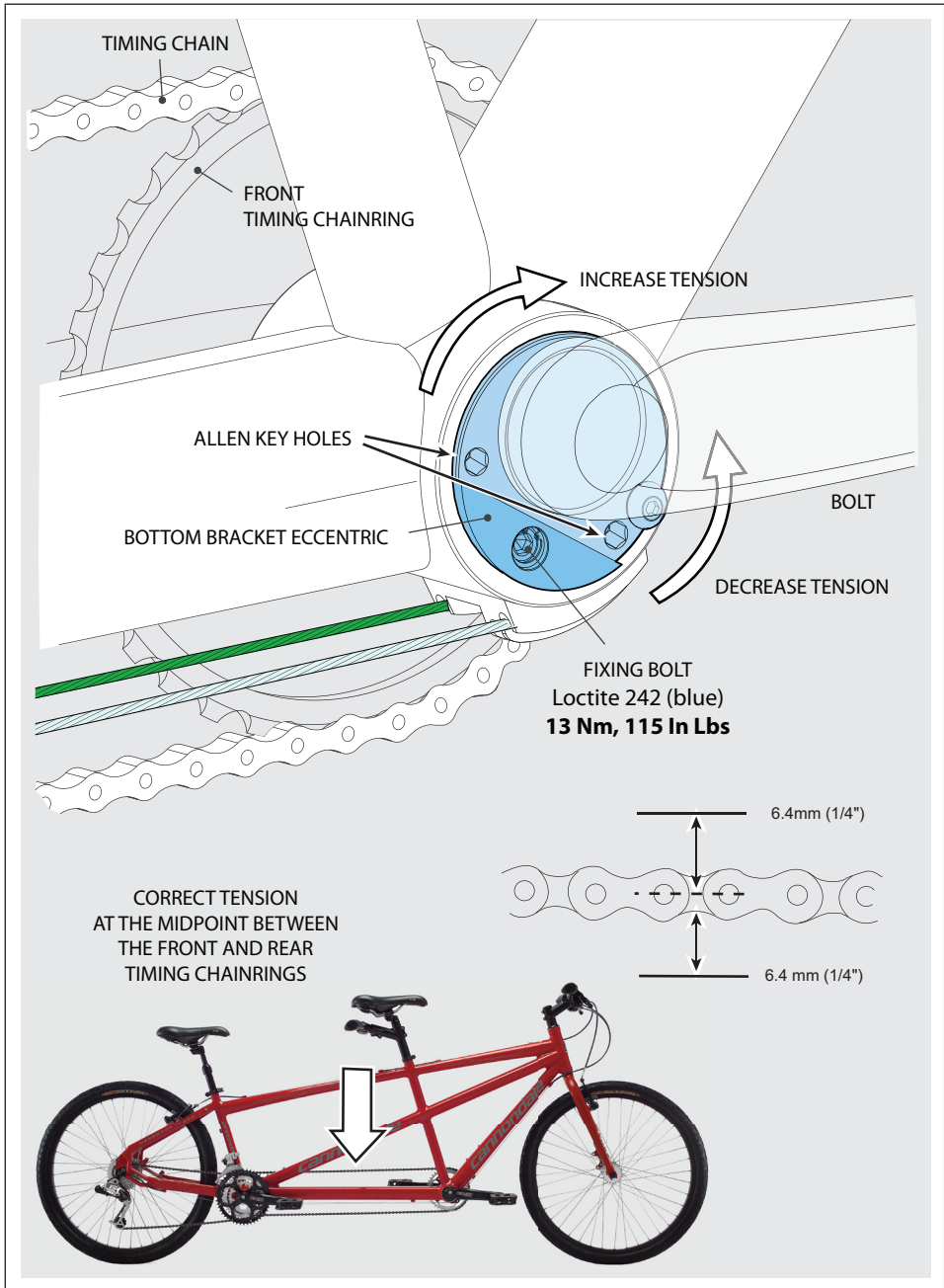

Figure 5.

## **Eccentric (DEALER ONLY)**

### **Installation**

1. Clean the BB shell and eccentric and apply a high quality bicycle bearing grease.
2. Apply Loctite 242 (blue) to the FIXING BOLT threads.
3. Slide the eccentric assembly into the drive side of the BB shell. Position the CENTERING BOLT on the right (drive) side of the bicycle. It locates on the face of the bottom bracket shell to center the assembly. It is not an adjustment; do not remove it.

### **Removal**

Periodic removal, cleaning and renewal of grease will help ensure that the eccentric can be rotated within the shell easily. This should only be done by a bike professional bike mechanic.

#### **To remove the eccentric from the bottom bracket shell:**

1. Loosening the fixing bolt. Turn it counter-clockwise enough to slide the complete eccentric assembly out of the shell from the drive side.

**NOTE:** Taping the head of the fixing bolt with a T-handle after it is loosened a turn or two. This can free a stuck wedge. Forcing the bolt with a stuck wedge can damage the threads.

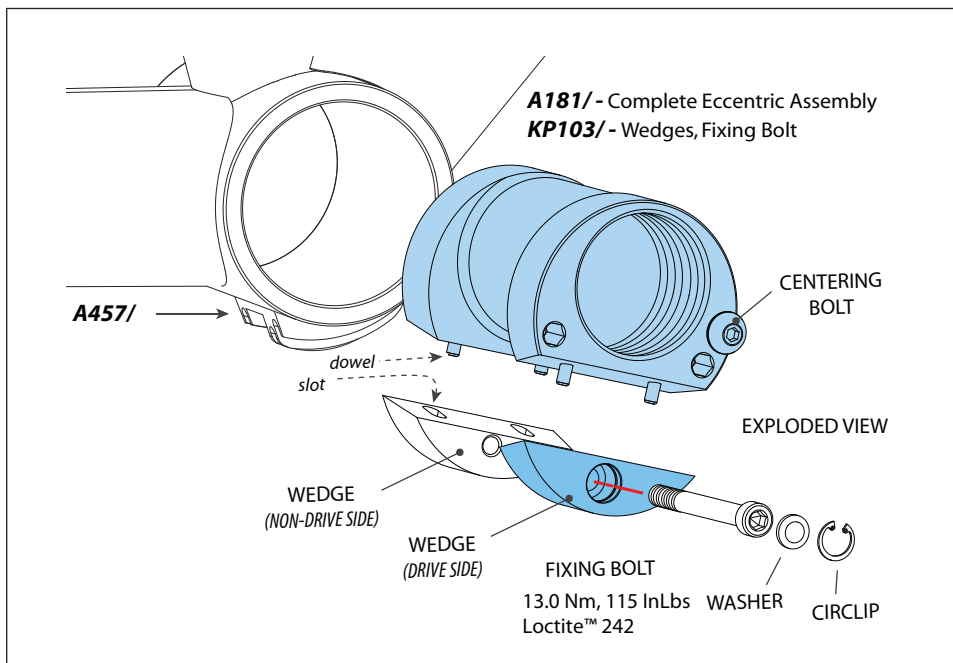

**Figure 6.**



## Rear Derailleur Hanger Replacement

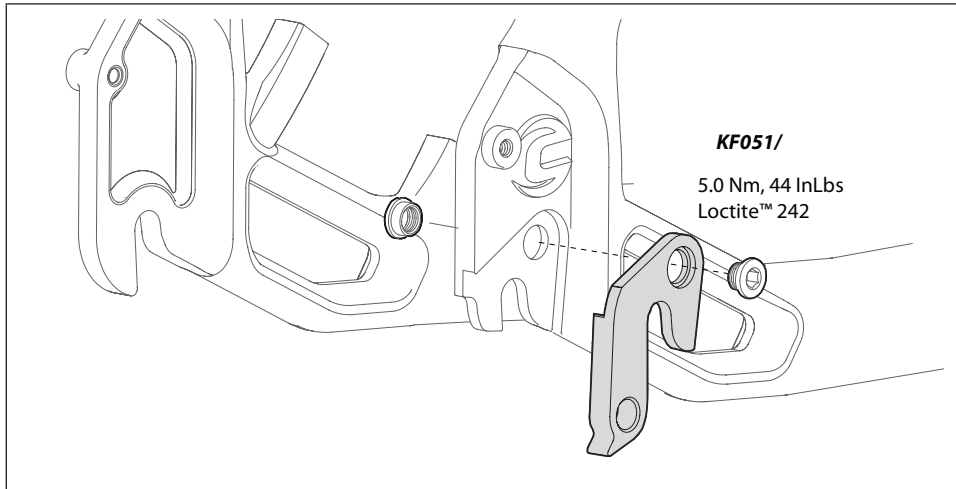

Figure 7.

## Stoker Bottom Bracket Cable Routing (DEALER ONLY)

Figure 8. shows the correct cable routing method at the stoker bottom bracket. All three cables ( rear brake, front derailleur, and rear derailleur) coming into this point will be bare from the captain BB area to the pulleys/guides. The rear cable guides on the boom tube will not be used. It is only necessary for disc brake housing.

**NOTE:** Even when disc brakes are used, both pulleys must be installed.

### **WARNING**

**ROUTE RIM BRAKE CABLE UNDER THE PIN IN THE LARGE PULLEY.** This is necessary to prevent the cable from dislocating from the pulley groove. If the cable is dislocated, you can lose your rear brakes. See Figure 8.

**YOU CAN BE SEVERELY INJURED, PARALYZED OR KILLED IF YOU IGNORE THIS WARNING.**

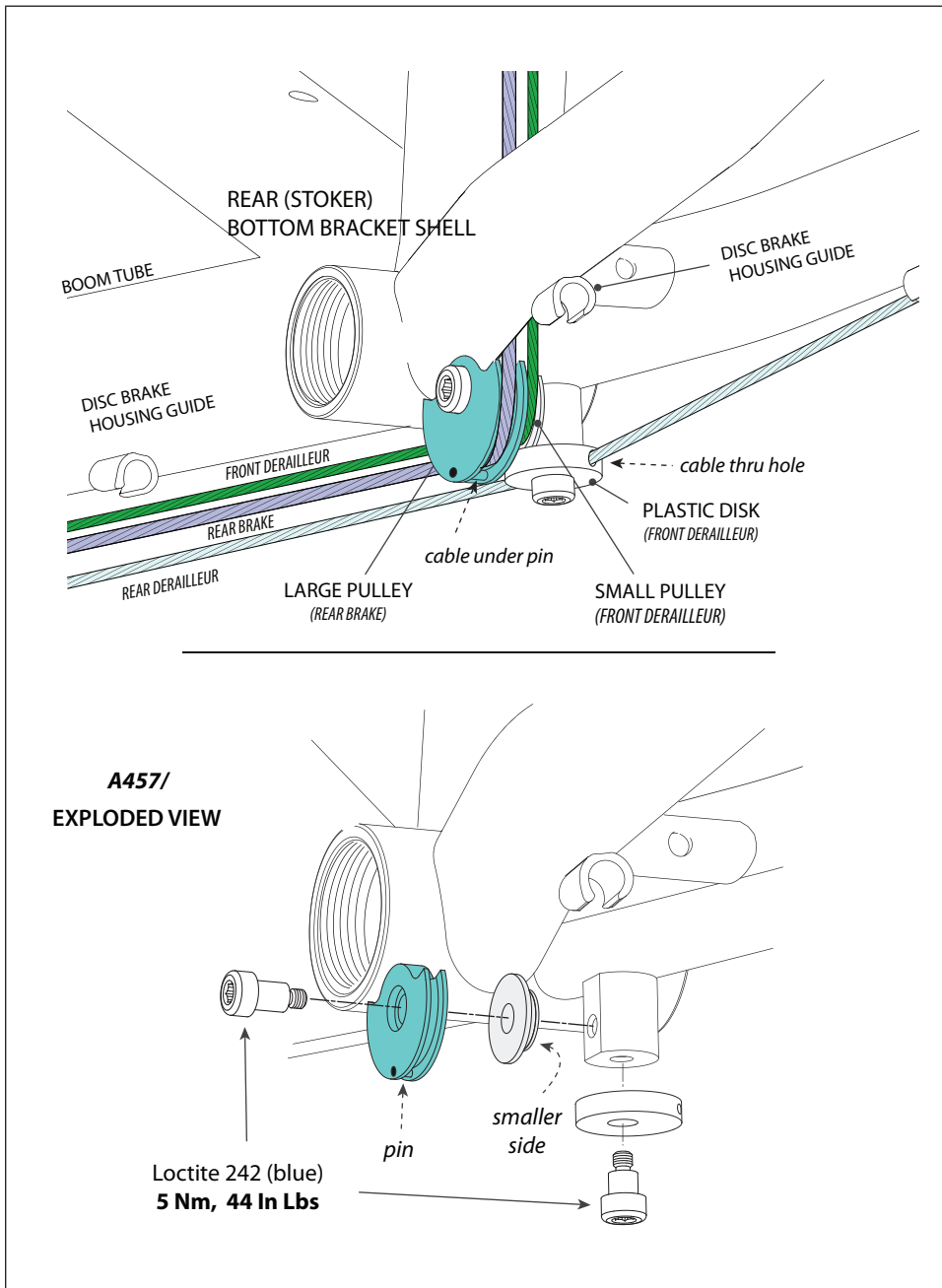

Figure 8.

## Housing Guides/ Cable Stops

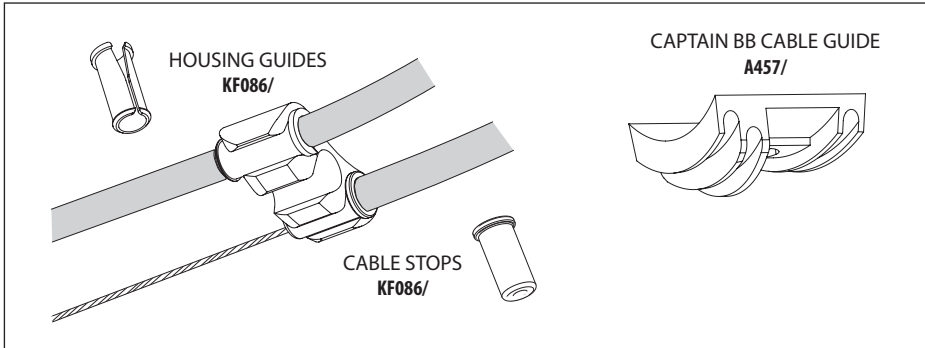

Figure 9.

## CANNONDALE KITS LIST

Cannondale kits are only available through an authorized Cannondale Dealer. For an up to date list of kits available for your bike, please visit our Tech Center at : <http://www.cannondale.com/tech/>

P/N	DESCRIPTION
<b>A457/</b>	KIT,BB CABLEGUIDE,TANDEM; 3 channel BB cable guide
<b>A181/</b>	KIT,BB ECCENTRIC,TANDEM/1FG; COMPLETE ASS'Y
<b>KP103/</b>	KIT,BB ECCENTRIC,HWARE
<b>KA027/</b>	KIT,STEM,STOKER,ADJUSTABLE; FOR USE WITH 31.6 SEATPOST AND 31.8 H'BAR DIAMETER
<b>KB002/</b>	KIT,HEADSET, SI FSA CARBON W/ 15MM TOPCAP
<b>KF051/</b>	KIT,DER.HANGER;SINGLE SIDED 2
<b>KF014/</b>	KIT,CABLESTOP, INSERTS - 2
<b>KF086/</b>	KIT,HYDRAUL. BRK GUIDES,10 PCS
<b>QC840/BBQ</b>	KIT,SEATBINDER,MTN QR,31.8,BLK-STOKER
<b>QC843/BBQ</b>	KIT,SEATBINDER,MTN QR,34.9,BLK-CAPTAIN
<b>QC841/BBQ</b>	KIT,SEATBINDER,MTN,31.8,BLK -STOKER
<b>QC842/BBQ</b>	KIT,SEATBINDER,MTN,34.9,BLK -CAPTAIN
<b>KF115/</b>	KIT,GEL,DYNAMIC,CARBON SEATPOST

# GEOMETRY AND SPECIFICATION

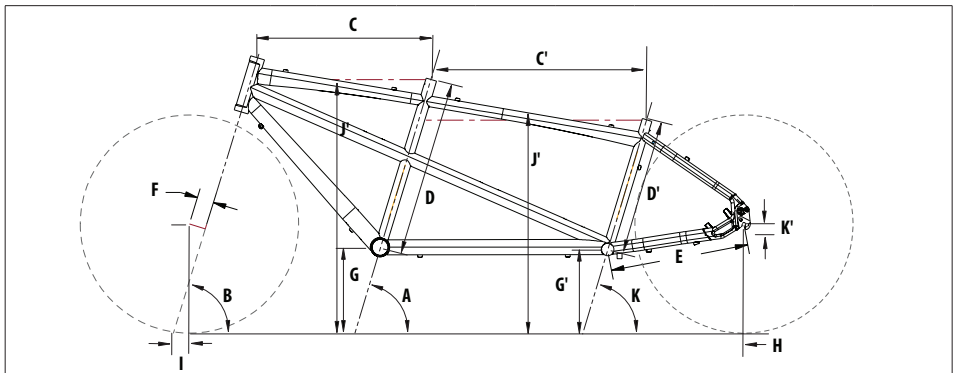

(in / cm), * same spec	ROAD				STREET				
	M/S	L/S	X/S	J/M	M/S	L/S	X/S	J/M	
SIZE (Front / Rear)									
FRONT SEAT TUBE ANGLE	A	73°	*	*	*	73°	*	*	*
REAR SEAT TUBE ANGLE	K	73°	*	*	*	73°	*	*	*
HEAD TUBE ANGLE	B	73°	*	*	*	71°	*	*	*
HORIZONTAL FRONT TOP TUBE LENGTH	C	21.5 / 54.5	22.0 / 56.0	22.6 / 57.5	23.6 / 60.0	22.5 / 57.1	23.0 / 58.5	23.6 / 60.0	24.6 / 2.5
HORIZONTAL REAR TOP TUBE LENGTH	C'	28.6 / 72.6	28.6 / 72.6	28.6 / 72.6	29.1 / 73.9	28.6 / 72.6	28.6 / 72.6	28.6 / 72.6	29.1 / 73.9
FRONT SEAT TUBE OVERALL LENGTH	D	19.0 / 48.3	20.0 / 50.8	22.0 / 55.9	23.0 / 58.4	18.0 / 45.7	19.0 / 48.3	21.0 / 53.3	22.0 / 55.9
REAR SEAT TUBE OVERALL LENGTH	D'	17.0 / 43.2	17.0 / 43.2	17.0 / 43.2	19.0 / 48.3	17.0 / 43.2	17.0 / 43.2	17.0 / 43.2	19.0 / 48.3
REAR SEAT TUBE MEASURED LENGTH		15.6 / 39.7	15.6 / 39.7	17.0 / 43.2	19.0 / 48.3	15.6 / 39.7	15.6 / 39.7	17.0 / 43.2	19.0 / 48.3
HEAD TUBE LENGTH		5.9 / 15.0	6.5 / 16.5	7.1 / 18.0	7.9 / 20.0	5.9 / 15.0	6.5 / 16.5	7.1 / 18.0	7.9 / 20.0
CHAINSTAY LENGTH	E	17.4 / 44.2	*	*	*	17.4 / 44.2	*	*	*
FORK RAKE	F	2.1 / 5.3	*	*	*	2.1 / 5.3	*	*	*
FRONT BOTTOM BRACKET HEIGHT	G	10.8 / 27.4	*	*	*	11.5 / 29.2	*	*	*
REAR BOTTOM BRACKET HEIGHT	G'	10.5 / 26.7	*	*	*	11.2 / 28.5	*	*	*
WHEELBASE	H	68.4 / 73.6	69.0 / 175.1	69.5 / 176.6	71.0 / 180.4	70.7 / 179.6	71.3 / 181.1	72.0 / 182.7	73.5 / 186.6
TRAIL	I	2.0 / 5.1	*	*	*	2.3 / 5.8	*	*	*
FRONT STANDOVER TOP TUBE MIDPOINT	J	28.2 / 71.7	30.6 / 77.7	31.6 / 80.3	32.5 / 82.6	27.6 / 70.2	29.8 / 75.8	30.9 / 78.6	31.8 / 80.8
REAR STANDOVER TOP TUBE MIDPOINT	J'	25.4 / 64.6	26.3 / 66.8	27.6 / 70.2	29.5 / 74.0	25.7 / 65.2	26.4 / 67.3	27.8 / 70.6	29.3 / 74.4
FRONT BOTTOM BRACKET DROP		2.9 / 7.4	*	*	*	1.5 / 3.8	*	*	*
REAR BOTTOM BRACKET DROP		3.2 / 8.1	*	*	*	1.8 / 4.6	*	*	*
FRONT CENTER DISTANCE		22.9 / 58.3	23.5 / 59.7	24.1 / 61.2	25.1 / 63.7	24.9 / 63.2	25.5 / 64.7	26.1 / 66.4	27.2 / 69.0
INTENDED USE (See page 2.)		CONDITION 1				CONDITION 2			
REAR BRAKE MOUNT		74mm POST MOUNT, or CANTILEVER							
	HEADSET	Campy style bearings: 41.8mm OD w/ 45° chamfers							
SEAT POST DIA.	FRONT	31.6 mm							
	REAR	27.2 mm							
DROPOUT SPACING	FRONT	100 mm							
	REAR	140 mm							
MAXIMUM WEIGHT LIMIT (See page 2.)		RIDER		LUGGAGE		TOTAL			
		500 lbs / 227 kg		75 lbs / 34 kg		575 lbs / 261 kg			

# Problems

## Travel Agent™

**BEFORE INSTALLATION, READ THESE INSTRUCTIONS AND WARNINGS COMPLETELY.** If you don't completely and thoroughly understand these instructions, don't have the proper tools, or aren't absolutely sure of what you are doing, do the right thing - **LEAVE THIS INSTALLATION TO AN EXPERIENCED, PROFESSIONAL BICYCLE MECHANIC. THESE ARE YOUR BRAKES: YOUR LIFE MAY QUITE LITERALLY BE IN YOUR HANDS!! IF YOU DON'T GET IT, DON'T MESS WITH IT!!**

The Travel Agent offers two different settings. These guidelines will help you determine whether you should use the “cable roller” setting or the “cable travel doubler” setting. Please note that the Travel Agent is

not recommended for use with all lever / brake combinations. Failure to follow these guidelines will produce less-than-desirable results.

- **Long-pull MTB lever + linear-pull brake = use roller setting**
- **Regular MTB lever + linear-pull brake = use cable travel doubler setting**
- **Road lever (including STI and Ergo) + linear-pull brake = use cable travel doubler setting**
- **Shimano “Servo-Wave” MTB lever + linear-pull brake = avoid this combination, period. Not compatible.**

**PLEASE USE THE DIAGRAMS ON THIS PAGE FOR REFERENCE.**

### Installation (Roller Setting)

1. Remove and recycle old cable, housing and cable noodle.
2. Place the Travel Agent in your linear-pull brake's noodle carrier, cut a new piece of housing to the appropriate length, and string brake cable through the lever and housing.
3. Feed the cable through the Travel Agent's outermost cable hole, around the outer cable pulley, and out the cable exit hole.
4. Make sure that the housing is firmly seated at both ends, then attach the brake cable to the brake arm and adjust per the brake manufacturer's instructions for proper brake pad clearance.

### Installation (Cable Travel Doubler Setting)

1. Remove and recycle old cable, housing and cable noodle.
2. Place the Travel Agent in your linear-pull brake's noodle carrier, cut a new piece of housing to the appropriate length, and string brake cable through the lever and housing.
3. Remove the Travel Agent from the brake's noodle carrier.
4. Feed the brake cable through the innermost cable hole, make sure the housing is firmly seated at both ends, pull any cable slack taut, and get ready to wrap the cable around the inner cable pulley.
5. Find the hole in the pulley that bridges the inner cable pulley to the outer cable pulley (the “bridging” hole) and aim this hole at the two o'clock position.
6. Feed the cable around the inner pulley and through the bridging hole.
7. Again make sure that both ends of the housing are properly seated and pull the cable taut once more. Make sure that the bridging hole is still aimed at the two o'clock position.
8. Now feed the cable counter-clockwise around the outer cable pulley and through the cable exit hole.
9. Pop the Travel Agent back into the brake's noodle carrier, then pull the cable as taut as possible and attach it to the brake arm.
10. Squeeze the brake lever firmly several times to seat the cable properly in the Travel Agent, then adjust the brake per the brake manufacturer's instructions for proper brake pad clearance.

11. Increased brake arm spring tension may be required to make the brakes return properly.

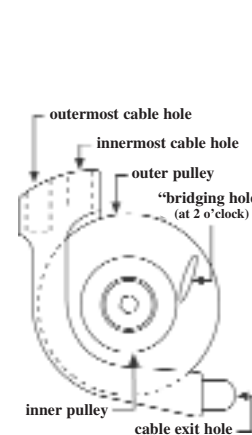

**Travel Agent**

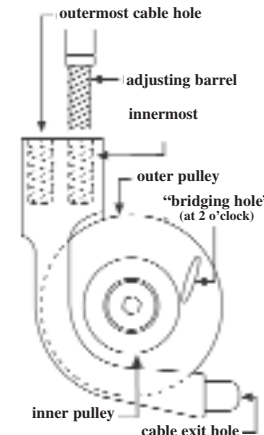

**Travel Agent With Adjusting Barrel**

### **Supplement: Travel Agents With Adjusting Barrels**

1. Before installation, be sure to thread the adjusting barrel into the correct cable hole for the desired setting; the adjusting barrel should be threaded into the outermost cable hole for the roller setting, and into the innermost cable hole for the cable travel doubler setting.
2. The adjusting barrel should be threaded in as far as possible prior to installation.
3. Proceed with the appropriate installation instructions.

### **WARNINGS**

1. Dirt and debris will clog the Travel Agent and result in poor performance. Keep your Travel Agent clean and free from debris.
2. Cable travel doubler setting only. The position of the bridging hole will change as the brake cable stretches, but if properly set up, should not vary beyond an acceptable limit. If the position of the bridging hole ever wanders past the 5 o'clock position, stop riding the bike immediately and reset the travel agent to its original specifications as described above.
3. Travel agents with adjusting barrels only. Never adjust the adjusting barrel in a way that will cause the bridging hole to move beyond the 5 o'clock position. If for any reason the position of the bridging hole ever wanders past the 5 o'clock position, stop riding the bike immediately, thread the adjusting barrel all the way down, and reset

the Travel Agent to its original specifications as described above. Also, never unthread the adjusting barrel to the point that insufficient threads are holding the barrel in place.

4. Before each ride, inspect the Travel Agent for loose hardware, cracks, dirt, proper cable flow, rotting cables, fraying cable strands, or anything else that may impede the performance of this product. Remember, these are your brakes!
5. Like all moving parts, brake cables fatigue and need to be replaced regularly in accordance with a preventative maintenance program.
6. Use this product at your own risk. We stand behind all of our products. However, we cannot be responsible for certain circumstances, including, but not limited to, incorrect installation, misuse of product, user error of any kind, damage to product, or failure to properly inspect and maintain this product regularly.

### **Problem Solvers™ LIMITED 2 YEAR WARRANTY**

This product is warranted against defects in materials and workmanship only, for 2 years from the original date of retail purchase by the consumer, subject to the limitations detailed below. This warranty is expressly limited to the repair or replacement of the original product, at the option of Problem Solvers, and is the sole remedy of this warranty. This limited warranty applies only to the original purchaser of this product and is not transferable. In no event shall Problem Solvers be liable for loss, inconvenience or damage, whether direct, incidental or otherwise resulting from breach of any express or implied warranty or condition, of merchantability, fitness for a particular purpose, or otherwise with respect to this product except as set forth herein.

This warranty does not cover the following:

- Damage due to improper assembly or follow-up maintenance or lack of skill, competence or experience of user.
- Products that have been modified, neglected, used in competition or for commercial purposes, misused or abused, involved in accidents or anything other than normal use.
- Damage or deterioration to the surface finish, aesthetics or appearance of the product.
- Normal wear and tear.
- Labor required to remove and/or refit and re-adjust the product within the bicycle assembly.

This warranty gives the consumer specific legal rights, and those right and other rights may vary from state to state.

We recommend that you have this product installed and maintained by a professional bicycle mechanic.

### **Contact Us:**

Problem Solvers™  
6400 West 105th Street  
Bloomington, MN 55438  
877.997.2572