

SYNAPSE

OWNER'S MANUAL SUPPLEMENT



 **WARNING**

Read this supplement and your *Cannondale Bicycle Owner's Manual*. Both contain important safety information. Keep both for future reference.

cannondale

Explicit Definitions

In this supplement, particularly important information is presented in the following ways:

 **DANGER**

Indicates a hazardous situation which, if not avoided, **will** result in death or serious injury.

 **WARNING**

Indicates a hazardous situation which, if not avoided, **may** result in death or serious injury.

NOTICE

Indicates special precautions that must be taken to avoid damage.

Cannondale Supplements

This manual is a “supplement” to your **Cannondale Bicycle Owner’s Manual**.

This supplement provides additional and important model specific safety, maintenance, and technical information. It may be one of several important manuals/supplements for your bike; obtain and read all of them.

Please contact your Authorized Cannondale Dealer immediately if you need a manual or supplement, or have a question about your bike. You may also contact us using the appropriate country/region/location information. See Contacting Cannondale in this supplement.

You can download Adobe Acrobat PDF versions of any manual/supplement from our website:

<http://www.cannondale.com>

Your Authorized Cannondale Dealer

To make sure your bike is serviced and maintained correctly, and that you protect applicable warranties, please coordinate all service and maintenance through your Authorized Cannondale Dealer.

NOTICE

Unauthorized service, maintenance, or repair parts can result in serious damage and void your warranty.

Contacting Cannondale

Cannondale USA

Cycling Sports Group, Inc.
1 Cannondale Way, Wilton CT, 06897, USA
1-800-726-BIKE (2453)

Cycling Sports Group Europe B.V

Mail: Postbus 5100
Visits: Hanzepoort 27
7570 GC, OLDENZAAL, Netherlands
Tel: +41 61 551 14 80
Fax: +31 54 151 42 40

CONTENTS

Safety Information	1-4
Technical Information	5-12
Replacement Parts.....	13

Intended Use

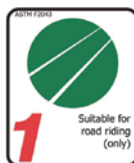

The intended use of all models is ASTM CONDITION 1, High-Performance Road.

WARNING

Please read your **Cannondale Bicycle Owner’s Manual** for more information about Intended Use and Conditions 1-5.

SAFETY INFORMATION

Important Composites Message

WARNING

Your bike (frame and components) is made from composite materials also known as “carbon fiber.”

All riders must understand a fundamental reality of composites. Composite materials constructed of carbon fibers are strong and light, but when crashed or overloaded, carbon fibers do not bend, they break.

For your safety, as you own and use the bike, you must follow proper service, maintenance, and inspection of all the composites (frame, stem, fork, handlebar, seat post, etc.) Ask your Cannondale Dealer for help.

We urge you to read PART II, Section D. “Inspect For Safety” in your Cannondale Bicycle Owner’s Manual BEFORE you ride.

YOU CAN BE SEVERELY INJURED, PARALYZED OR KILLED IN AN ACCIDENT IF YOU IGNORE THIS MESSAGE.

Inspection & Crash Damage Of Carbon Frames/Forks

WARNING

AFTER A CRASH OR IMPACT:

Inspect frame carefully for damage (See PART II, Section D. Inspect For Safety in your Cannondale Bicycle Owner’s Manual.)

Do not ride your bike if you see any sign of damage, such as broken, splintered, or delaminated carbon fiber.

ANY OF THE FOLLOWING MAY INDICATE A DELAMINATION OR DAMAGE:

- An unusual or strange feel to the frame
- Carbon which has a soft feel or altered shape
- Creaking or other unexplained noises,
- Visible cracks, a white or milky color present in carbon fiber section

CONTINUING TO RIDE A DAMAGED FRAME INCREASES THE CHANCES OF FRAME FAILURE, WITH THE POSSIBILITY OF INJURY OR DEATH OF THE RIDER.

YOU CAN BE YOU SERIOUSLY INJURED, PARALYZED OR KILLED IF YOU IGNORE WARNINGS.

Disc Brake on Road Bikes

WARNING

Relative to conventional rim brakes, disc brakes are less affected by water, do not wear or heat the rims and therefore are more consistent. Disc brakes also may be more powerful.

To minimize risk of injury or accidents:

- Understand that road bikes have a relatively small tire contact patch (part of the tire that touches the road). In order to apply the brakes safely and effectively, you may need more or less braking force in different situations. You need to take into account various road and weather conditions that can affect traction.
- Disc brakes are excellent, but not some kind of magic. Take some time riding your new disc brake road bike in lower risk circumstances to get used to the feel and performance of the disc brakes and tires.

YOU CAN BE SEVERELY INJURED, PARALYZED OR KILLED IN AN ACCIDENT IF YOU IGNORE THIS MESSAGE.

Tightening Torques

Correct tightening torque for the fasteners (bolts, screws, nuts) on your bicycle is very important to your safety. Correct tightening torque for the fasteners is also important for the durability and performance of your bicycle. We urge you to have your Dealer correctly torque all fasteners using a torque wrench. If you decide to torque fasteners yourself always use a torque wrench.

Find Tightening Torque Information :

The wide range of bicycle models and components used means that a listing of tightening torque would be out of date by the time it was published. Many fasteners should be installed with a thread locking adhesive such as Loctite®.

To determine correct tightening torque and any adhesive application for a fastener we ask you to check:

- Many components are marked. On-product marking is becoming common.
- Torque specs in the component manufacturers instructions shipped with your bicycle.
- Torque specs listed on the websites of component manufacturers.
- With your Dealer. Dealers have access to current data and have experience with correct torque for most fasteners.

Trainers

If you ride a trainer that requires removal of the front wheel and clamps the fork dropouts: Be sure your fork quick release is tight! Relative movement will wear parts, weaken and damage your bike.

If you ride a trainer that holds the bike up by clamping the rear quick release between two cones: Take off the nice, lightweight quick release that came with your bike. Substitute a heavy, classic all steel quick release and clamp it tight! Relative movement will wear parts, weaken and damage your bike. Note that many modern quick releases will not fit the clamping cones in this kind of trainer because their shapes are incompatible.

For thru axles, make sure you follow the trainer manufacturer instructions for the use of any specialized adapters

Be particularly cautious with a carbon frame or fork. Carbon is relatively soft, not abrasion resistant. If there is any relative movement, carbon will wear quickly.

If you ride a trainer a lot, consider using an old bike: Corrosion from sweat will take its toll. Weight is irrelevant. Save wear on your expensive components.

Ask your dealer for help with trainers, the right one and the correct way to use it.

NOTICE

TRAINERS - Improperly mounting a bike in a trainer, or using one that is not compatible with your particular bike frame can cause serious damage.

WATER BOTTLES - An impact, crash, or loose bottle cage can result in damage to your frame.

This kind of damage is not covered by the Cannondale Limited Warranty.

Water Bottles

Side impacts to a water bottle or cage can result in damage threaded inserts due to the leverage on a very small area. In a crash, certainly the last thing you should be worried about is saving the threaded inserts in your frame. However, when you are storing or transporting your bike, take steps to prevent situations where a water bottle may be hit or bumped by a strong force that would cause damage. Remove bottle and cage when you are packing your bike for travel.

Periodically check the attachment of the bottle cage; tighten the cage bolts if necessary. Don't ride with a loose bottle cage. Riding with loose cage bolts can produce a rocking motion or vibration of the attached cage. A loose cage will damage the insert and possibly lead to the inserts to pull out.

It may be possible to repair a loose insert, or install another insert only if the frame is undamaged. Replacement requires the use of a special tool. If you notice damage to the threaded insert, please ask your Cannondale Dealer for help.

Building Up A Frame Set

Before building up a frame set, consult with your Cannondale Dealer and the component manufacturers, and discuss your riding style, ability, weight, and interest in and patience for maintenance.

Make sure the components chosen are compatible with your bike and intended for your weight and riding style.

Generally speaking, lighter weight components have shorter lives. In selecting lightweight components, you are making a trade-off, favoring the higher performance that comes with less weight over longevity. If you choose more lightweight components, you must inspect them more frequently. If you are a heavier rider or have a rough, abusive or "go for it" riding style, buy heavy duty components.

Read and follow the component manufacturers warnings and instructions.

TECHNICAL INFORMATION

Frame Specification

FRAME	Synapse HM, Synapse Carbon
HEAD TUBE	See, "Headset Bearings"
BOTTOM BRACKET	BB30A 73mm
FRONT DERAILLEUR	braze-on / 1X
SEAT POST DIA	25.4 mm
MINIMUM SEAT POST INSERT	65 mm
BRAKES	Flat Mount
REAR AXLE	142 x 12mm. M12 x 1.0
MAXIMUM WEIGHT LIMIT (Lbs/Kg)	275/125

Headset Bearings - (size specific)

FRAME SIZE (cm)	UPPER BEARING	LOWER BEARING	OFFSET	CROWN DIA.
56, 58, 61	1 1/8" ACB 45/45, 41.8mm O.D. FSA - MR121 Cannondale- K35018/	1 3/8" ACB 36x45, 48.9mm O.D. FSA - MR031 Cannondale - K35038	45mm	54mm
51, 54		1 1/4" ACB 45/45, 46.8mm OD FSA - MR082 Cannondale - K35028	55mm	52mm
44, 48		1 1/8" ACB 45/45, 41.8mm OD FSA MR121 / K35018	60mm	50 mm

NOTICE

Do not face, surface, or cut the head tube bearing cups. When removing adapters, bearings, or cup from, extra care must be used so that the tool used to drive out the bearing is not located on any part a bonded cup.

Bottom Bracket – BB30A 73mm

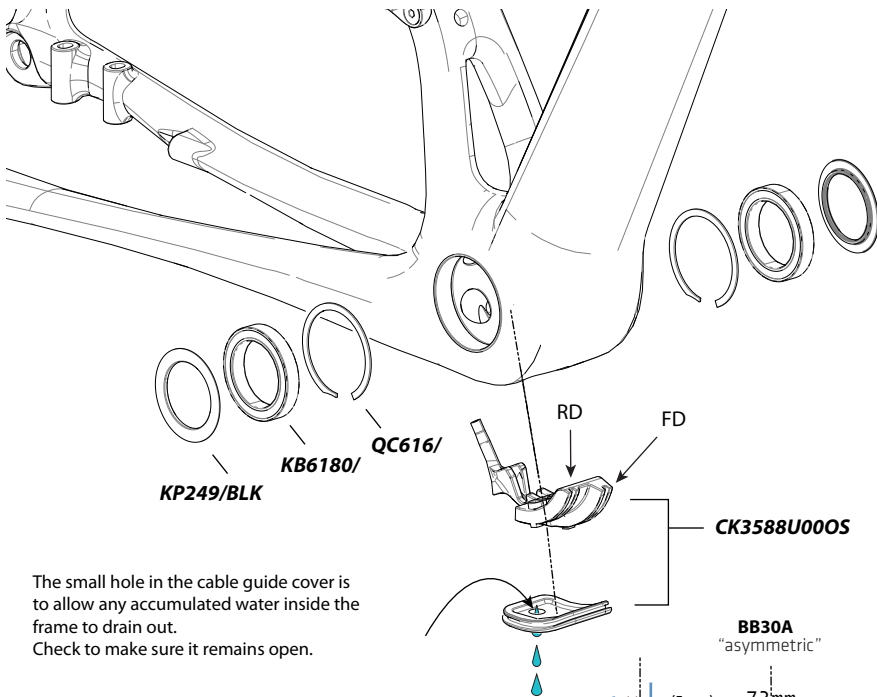

The small hole in the cable guide cover is to allow any accumulated water inside the frame to drain out. Check to make sure it remains open.

SI HOLLOWGRAM	BB30A-73
Si Spindle Length	109 mm
Spacer Left (non-drive)	2.5 mm
Spacer Right (drive)	2.6 mm

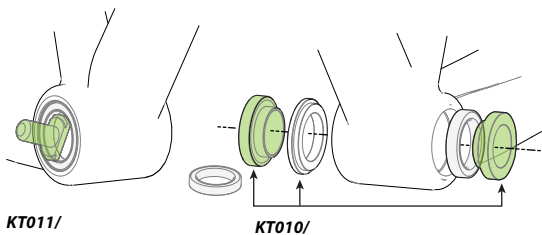
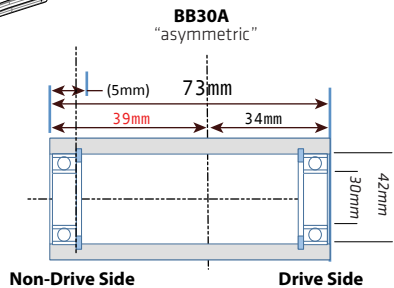

Bearings

Inspect bearing condition annually (at a minimum) and anytime the crank set assembly is disassembled or serviced. With the crank set removed, rotate the inner bearing race of both bearings; rotation should be smooth. No play or movement inside the shell. If the bearing is damaged, replace both bearings with new ones.

Remove the old bearings with the bearing removal tool **KT011/**.

To install bearings, use a headset press and Cannondale tool **KT010/**. Clean inside of shell apply a high-quality bicycle bearing grease to the inside surface. Press bearing one at a time. Press each bearing until seated. Following installation, apply a light coating of a high-quality bicycle bearing grease to both sides of each bearing to help repel moisture.

Do not re-use removed bearings. Install both bearings as a new set.

NOTICE

BEARINGS - Repeated removal and reinstallation can damage BB shell surfaces resulting in poor bearing fit.

- Do not face, mill or machine the bottom bracket shell for any reason.
- Repeated removal and reinstallation of BB components could result in damage to the shell and is not recommended.

Damage caused by improper installation/removal is not covered under your warranty.

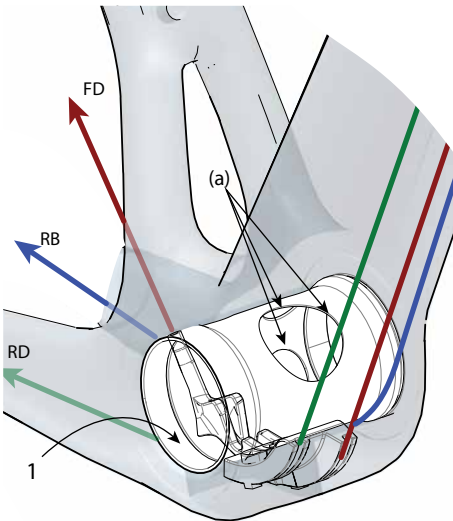

BB Internal Routing

NOTICE

Keep all cables and wires outside the inner bonded alloy BB shell (1). Do not route cables or wires inside the inner alloy shell.

Secure all mechanical cables and electronic wires safely inside the frame, so they cannot unintentionally enter the inner alloy BB shell through the access holes (a). The access holes are only to support installation and removal of parts through the frame tube easier. Do not permit cables or wires to unintentionally enter the shell through these holes.

Mechanical cables and electronic wires that contact the rotating crank set spindle can cause serious component damage.

Geometry

- A Seat Tube Length
- B Top Tube Horizontal
- D Head Tube Angle
- E Seat Tube Angle
- F Standover
- G Head Tube Length
- H Wheelbase
- I Front Center
- J Chain Stay Length
- K Bottom Bracket Drop
- L Bottom Bracket Height
- M Fork Rake
- N Trail
- O Stack
- P Reach
- Z Head Tube Height

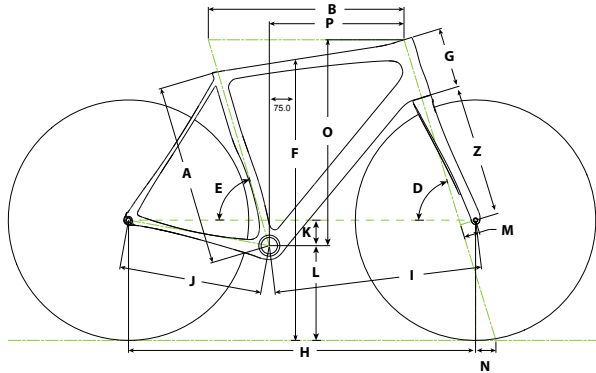

Dimensions = (centimeter/inches)

SIZE	44	48	51	54	56	58	61
A	37.0/14.6	40.7/16.0	44.3/17.4	48.0/18.9	52.0/20.5	55.0/21.7	59.0/23.2
B	50.5/19.9	51.7/20.4	53.1/20.9	54.7/21.5	56.1/22.1	57.9/22.8	60.4/23.8
C							
D	70.2°	70.8°	71.7°	★	73.0°	★	★
E	74.7°	74.6°	74.3°	73.9°	73.5°	73.0°	72.5°
E'							
F							
G	10.3/4.1	12.2/4.8	13.7/5.4	16.1/6.3	17.3/6.8	19.7/7.8	22.9/9.0
H	98.9/38.9	99.6/39.2	99.4/39.2	100.8/39.7	99.5/39.2	100.9/39.7	102.8/40.5
I	59.1/23.3	59.8/23.5	59.6/23.5	60.9/24.0	59.6/23.5	60.9/24.0	62.7/24.7
J	41.0/16.1	★	★	★	★	★	★
K	7.5/3.0	★	★	7.3/2.9	★	7.0/2.8	★
L	27.0/10.6	★	★	27.2/10.7	★	27.5/10.8	★
M	6.0/2.4	★	5.5/2.2	★	4.5/1.8	★	★
N	6.0/2.4	5.6/2.2	5.6/2.2	★	5.8/2.3	★	★
O	51.0/20.1	53.0/20.9	55.0/21.6	57.0/22.5	59.0/23.2	61.0/24.0	64.0/25.2
P	36.5/14.4	37.1/14.6	37.7/14.8	38.2/15.1	38.6/15.2	39.3/15.5	40.2/15.8
Z	38.1/15.0	★	★	★	★	★	★

All Specifications subject to change without notice.

* - Indicates same.

Seat Post

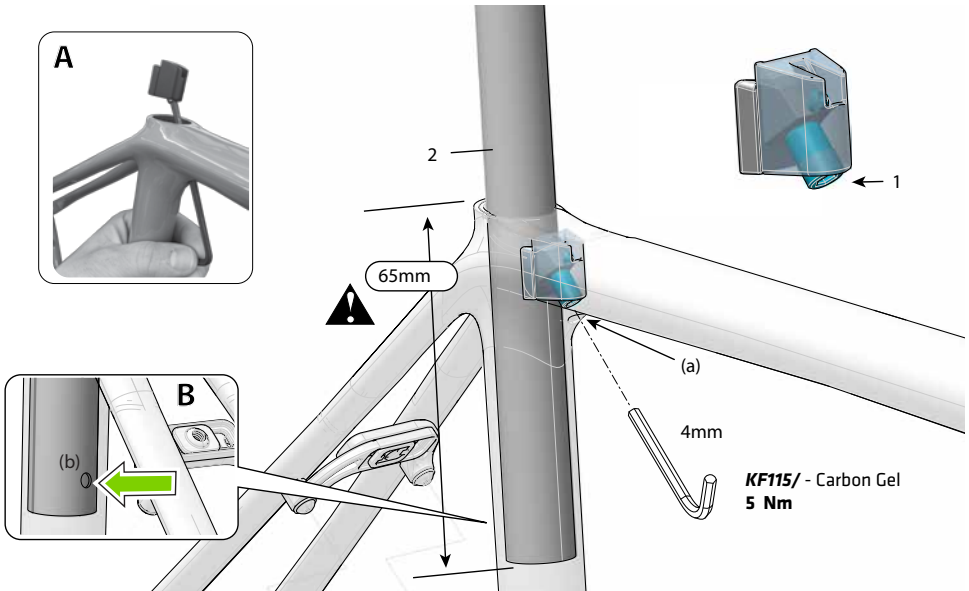

To adjust the seat post height:

1. Insert 4mm hex through the underside seat tube opening (a) as shown.
2. Loosen the binder screw (1) sufficient to move the seat post up or down.
3. Set the seat post (2) position.

Make sure the seat post is visible through the inspection hole (b) (inset B). This ensures 65mm Minimum Seat Post Insertion.

4. Tighten the binder screw to 5 Nm.

To remove binder:

1. Loosen binder screw (1) and remove the seat post.
2. Use the 4mm allen hex tool to push the binder out of the top of the seat tube. See inset A.

For more information about carbon fiber seat posts, see also "APPENDIX D. Care and Maintenance of Carbon Fiber Seat Posts" in your Cannondale Bicycle Owner's Manual.

NOTICE

Use only a 25.4mm seat post. Do not use shims or adapters.

Do not force a seat post into the frame.

Frame Size (cm)	Maximum Seatpost Depth (mm)
44	100
48	110
51	120
54	130
56	170
58	200
61	240

If the seat post length is cut, make sure the 65mm minimum insert length is maintained.

Periodically clean and apply carbon gel **KF115/** to the inside of the seat tube and the seat post. Do not use grease.

If a SHIMANO Di2 system battery is installed in the seat post ensure, sufficient wiring length to prevent damage or battery disconnection.

SiSL Compression Assembly - K35058

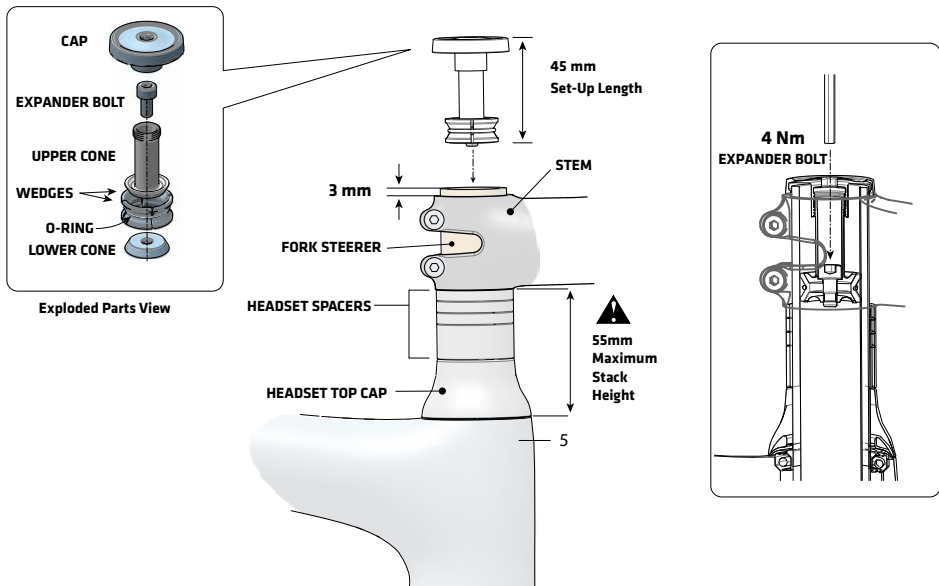

Installation

1. Assemble the fork, headset, spacers, and stem into the head tube. The fork steerer is to extend 3mm above the top of the stem.
2. Lightly tighten the stem bolts.
3. Set-up the compression assembly to 45mm length. Adjust the length by threading the cap on the upper cone.
4. Insert the compression assembly into the steerer tube.
5. Insert an 4mm Allen key through the hole in the cap and into the expander bolt. Tighten the expander bolt to 4 Nm.
6. Set bearing preload. Insert a 5mm allen key into the cap. Turn the entire top cap clockwise to increase bearing preload. Turning it counter-clockwise will decrease the preload.
7. When the headset preload is set, turn the stem to align the handlebar with the front wheel and tighten the stem clamp bolts to the torque specified for the stem. Consult the stem manufacturer's instructions. The torque values for components are often marked on the part.

⚠ WARNING

The installation and adjustment to be performed by a professional bike mechanic. Incorrect installation can result damage leading to a accident.

DO NOT EXCEED THE MAXIMUM STACK HEIGHT (55mm) OR LOCATE SPACERS ON TOP OF THE STEM.

YOU CAN BE SEVERELY INJURED, PARALYZED OR KILLED IN AN ACCIDENT IF YOU IGNORE THESE WARNINGS.

Di2 Battery Seat Post Installation

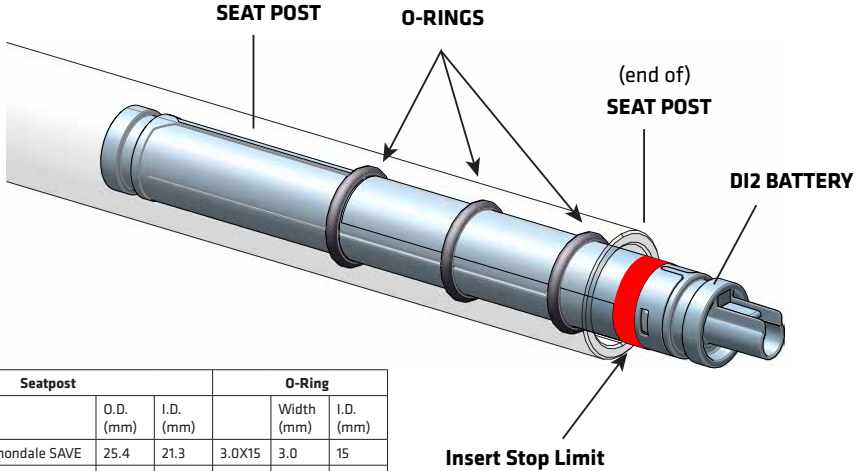

Seatpost	O-Ring		O-Ring		
	O.D. (mm)	I.D. (mm)		Width (mm)	I.D. (mm)
Cannondale SAVE	25.4	21.3	3.0X15	3.0	15
FSA SL-K	25.4	20.3	2.5X15	2.5	15
Cannondale C2	25.4	19.0	1.5X15	1.5	15

The Shimano Di2 battery fits within the inside diameter of the seat post.

The battery is retained by the placement of specifically sized O-rings on the outside of the battery as marked by the Cannondale label applied to it.

The O-rings, when installed properly are sufficient to retain the battery. See the table above.

To install the O-ring:

Select the correct size O-rings for the seat post in use.,

Clean the outside of the battery surface with a clean lint-free shop towel. Also clean the inside of the seat post.

Position the three O-ring on the label surface as indicated.

Insert the batter and O-rings into the bottom of the seat up to the "STOP Insert" red line limit.

When installing the battery fitted seat post into the frame, make sure there is adequate slack in the harness wiring to enable removal or seat post adjustment.

NOTICE

- Do not use any cleaners or solvents on the battery or seat post.
- It is important that you DO NOT use grease or other lubricants which will cause the O-rings to slide.
- When installing the battery fitted seat post into the frame, make sure there is adequate slack in the harness wiring to enable removal or seat post adjustment.

DT Guide Configurations

Shimano Di2

- Insert Shimano junction box, RS910 (1), into DT guide base (2) before final assembly into the frame making sure the charging port is towards the rear of the bike.
- Rotate the junction box 15 degrees in the base to secure its position.
- Attach E-Tube wires.
- Hook the rear of the guide (a) into the DT port (b) and then continue to push the guide in the DT. Make sure the forward tab (c) is hooked under the front of the DT port.
- Install the DT Guide – Di2 Cap (3) starting from the back and working forward.

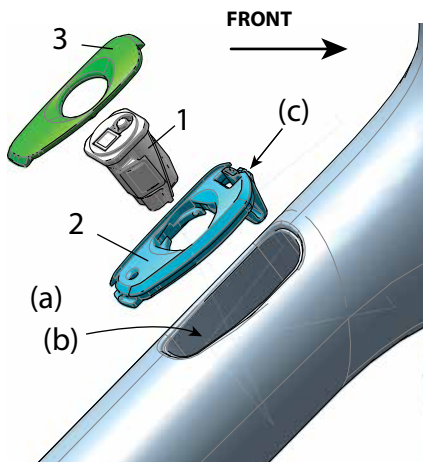

SRAM eTap

- Hook the rear of the guide into the DT port and then continue to push the guide base (2) in the DT port (a).
- Make sure the forward tab is hooked under the front of the DT port wall.
- Install the DT Guide – eTap Cap (4) starting from the back and working to front.

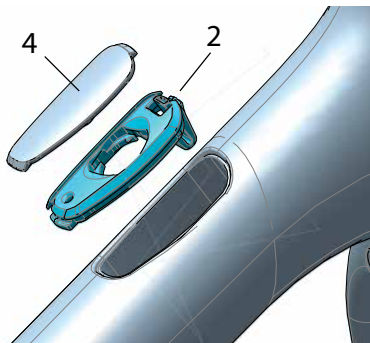

Mechanical

- Loosen the bolt (5) enough so the head is above the top of the mechanical DT guide (6).
- Hook the rear of the guide into the DT port and then continue to push the guide in the DT.
- Make sure the forward tab is hooked under the front of the DT port.
- Tighten the bolt until the head is lightly seated. DO NOT OVER-TIGHTEN.

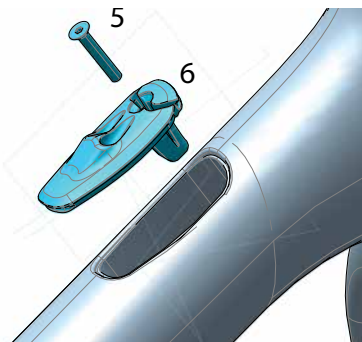

Replacement Parts

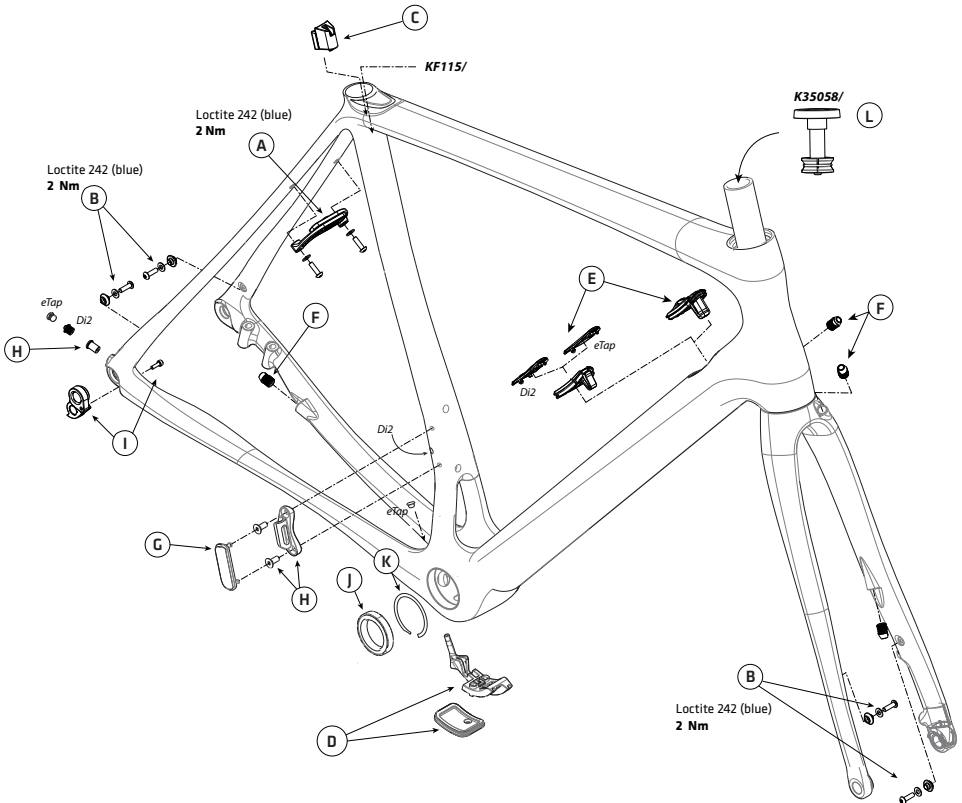

ID	CODE	DESCRIPTION
A	CK1168U100S	Adjustable Fender Bridge BLK
B	K11018	Road Fender Mount Hardware
C	KP448/	Seat Binder Wedge Super X
D	CK3588U000S	BB Cable Guide
E	CK3568U000S	Synapse Crb DT Cable Guide
F	K32048	Shift And Brake Grommets
G	CK3578U000S	Synapse Crb FD 1X Cover
H	CK3598U000S	Synapse Crb FD Hanger
I	KP302/	Dropout Cable Stop 20X
I	KP419/	Der Hanger X12

ID	CODE	DESCRIPTION
	K35018	1 1/8 Crb Headset No Crown Race
	K35028	1 1/4 Crb Headset No Crown Race
	K35038	1 3/8 Crb Headset No Crown Race
j	KB6180/	Bearing BB Si 2PCS BLU
K	QC616/	Circlips 2x BB Si
	K83038	Ratchet Lever Maxle 100x12 125mm
	K83048	Adjustable Lever Maxle 100x12 125mm
	K83058	Ratchet Lever Syntace 142x12 165mm
	K83068	Adjustable Lever Syntace 142x12 165mm
L	K35058	SISL Compression Assy.
	KF115/	Kit Gel Dynamic Carbn Seatpost

CANNONDALE USA

Cycling Sports Group, Inc.
1 Cannondale Way,
Wilton CT, 06897, USA
1-800-726-BIKE (2453)

CANNONDALE EUROPE

Cycling Sports Group Europe B.V
Mail: Postbus 5100
Visits: Hanzepoort 27
7570 GC, OLDENZAAL, Netherlands
Tel: +41 61 551 14 80
Fax: +31 54 151 42 40

WWW.CANNONDALE.COM

© 2017 Cycling Sports Group
SYNAPSE Owner's Manual
Supplement - 134917 Rev 1



CYCLING SPORTS GROUP