

Habit

Owner's Manual Supplement



 **WARNING**

READ THIS SUPPLEMENT AND YOUR CANNONDALE BICYCLE OWNER'S MANUAL. Both contain important safety information. Keep both for future reference.

cannondale

Safety Messages

In this supplement, particularly important information is presented in the following ways:



WARNING

Indicates a hazardous situation which, if not avoided, may result in death or serious injury.

NOTICE

Indicates special precautions that must be taken to avoid damage.

The following symbols are used in this manual:

Symbol	Name	Description
	NGLI-2 synthetic grease	Apply NGLI-2 synthetic grease.
	Carbon gel	Apply carbon gel (friction paste) KF115/
	Medium-strength removable thread lock	Apply Loctite® 242 (blue) or equivalent.

Cannondale Supplements

This manual is a “supplement” to your [Cannondale Bicycle Owner’s Manual](#).

This supplement provides additional and important model specific safety, maintenance, and technical information. It may be one of several important manuals/supplements for your bike; obtain and read all of them.

Please contact your Authorized Cannondale Dealer immediately if you need a manual or supplement, or have a question about your bike. You may also contact us using the appropriate country/region/location information.

You can download Adobe Acrobat PDF versions of any manual/supplement from our website:
<http://www.cannondale.com>.

Contacting Cannondale

Cannondale USA
Cycling Sports Group, Inc.
1 Cannondale Way,
Wilton CT, 06897, USA
1-800-726-BIKE (2453)

Cycling Sports Group Europe B.V
Mail: Postbus 5100
Visits: Hanzepoort 27
7570 GC, OLDENZAAL, Netherlands
Tel: +41 61 551 14 80
Fax: +31 54 151 42 40

CONTENTS

Safety Information	2-6
Technical Information	7-27
Replacement Parts	28-29
Tightening Torques	30
Maintenance	31
Notes	32

Your Cannondale Dealer

To make sure your bike is serviced and maintained correctly, and that you protect applicable warranties, please coordinate all service and maintenance through your Authorized Cannondale Dealer.

NOTICE

Unauthorized service, maintenance, or repair parts can result in serious damage and void your warranty.

SAFETY INFORMATION

Important Composites Message

WARNING

Your bike (frame and components) is made from composite materials also known as "carbon fiber."

All riders must understand a fundamental reality of composites. Composite materials constructed of carbon fibers are strong and light, but when crashed or overloaded, carbon fibers do not bend, they break.

For your safety, as you own and use the bike, you must follow proper service, maintenance, and inspection of all the composites (frame, stem, fork, handlebar, seat post, etc.) Ask your Cannondale Dealer for help.

We urge you to read PART II, Section D. "Inspect For Safety" in your [Cannondale Bicycle Owner's Manual](#) BEFORE you ride.

You can be severely injured, paralyzed or killed in an accident if you ignore this warning.

Inspection & Crash Damage Of Carbon Frames/Forks

WARNING

After A Crash Or Impact:

Inspect frame carefully for damage (See PART II, Section D. Inspect For Safety in your [Cannondale Bicycle Owner's Manual](#)).

Do not ride your bike if you see any sign of damage, such as broken, splintered, or delaminated carbon fiber.

Any of the following may indicate a delamination or damage:

- An unusual or strange feel to the frame
- Carbon which has a soft feel or altered shape
- Creaking or other unexplained noises,
- Visible cracks, a white or milky color present in carbon fiber section

Continuing to ride a damaged frame increases the chances of frame failure, with the possibility of injury or death of the rider.

Intended Use



The intended use of all models is ASTM CONDITION 4, All-Mountain.

WARNING

Understand your bike and its intended use. Using your bike the wrong way is dangerous.

Please read your [Cannondale Bicycle Owner's Manual](#) for more information about Intended Use and Conditions 1-5.

Servicing

WARNING

This supplement may include procedures beyond the scope of general mechanical aptitude.

Special tools, skills, and knowledge may be required. Improper mechanical work increases the risk of an accident. Any bicycle accident has risk of serious injury, paralysis or death.

To minimize risk we strongly recommend that owners always have mechanical work done by an Authorized Cannondale Dealer.

Maximum Fork Length

Maximum Fork Length is an important frame safety testing specification for front suspension mountain bikes. You must observe the measurement when installing headset parts, headset adapters, installing and adjusting a fork, and selecting replacement forks.

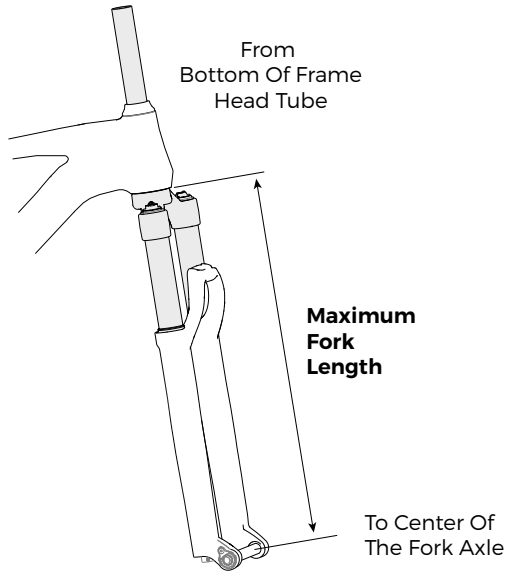

WARNING

You must select a replacement fork not only based on head tube diameter but the critical factor of frame maximum fork length.

Do not exceed maximum fork length. Exceeding the MAXIMUM FORK LENGTH limit can overload the frame causing it to break while riding.

Your retailer MUST follow and observe this specification for your bike. For Maximum Fork Length specifications for Cannondale bicycles, see www.cannondale.com.

You can be severely injured, paralyzed or killed in an accident if you ignore this warning.

Tire Size x Maximum Width

WARNING

Observe the Tire Size x Maximum Width for your bike found in the “Specifications” page of this manual.

Mounting the wrong size tires can result in the tires hitting the fork or frame when riding. If this happens, you can lose control of your bike and you can be thrown off, a moving tire can be stopped because it touches the fork or frame.

Do not mount oversized tires, ones that rub or hit the fork or frame, ones that result in too little clearance, or ones that can hit the fork or frame when the suspension is fully compressed or when riding.

Take care that the tires you select are compatible with your bike’s fork or frame design. Also, be sure to follow the manufacturer’s recommendations of your front fork and rear shocks.

When you are considering tires for your bike consider..

The actual measured size of a tire may be different than its sidewall marking. Each time you mount a new tire, take the time to inspect the actual clearance between the rotating tire and all parts of the frame. The U.S. Consumer Product Safety Commission (CPSC) requires at least 1/16” (1.6 mm) tire clearance from any part of the bike. Allowing for lateral rim flex and a wheel or rim that is out-of-true will likely mean choosing a rear tire that provides even more clearance than the CPSC recommends.

Ask your dealer for the right tires for your bike and its particular components!

You can be severely injured, paralyzed or killed in an accident if you ignore this warning.

Rear Shocks

WARNING

Select only compatible shocks and forks for your bike. Do not modify your bike in any way to mount one.

Have your shock or fork installed by a professional bike mechanic

Riding with the wrong rear shock can damage the frame. You could have a serious accident. Make sure the total travel, eye-to-eye length, and stroke length of the rear shock you select meet the "Specifications" listed in this manual.

When selecting different shocks or forks for your bike, make sure that the shock or fork you select is compatible with your bike's design and how you will use your bike.

You can be severely injured, paralyzed or killed in an accident if you ignore this warning.

Minimum Seat Post Insert

WARNING

Make sure at least 100 mm of the seat post is inserted into the frame at all times.

Failure to insert the seat post at least 100 mm can place a very high stress on the seat tube top tube junction causing the frame to fail while riding.

Remove the seat post. Measure 100 mm from the bottom of the seat post. Use a permanent marker to mark the post at 100 mm.

When adjusting the seat post height in the seat tube, never adjust the seat post so that the line you mark is above the top edge of the seat tube.

You must also be aware that bicycle seat posts are permanently marked by the manufacturer with a "minimum insert" line on the seat post itself. You must not rely on this marking as an indication of the proper minimum seat post insertion depth.

You can be severely injured, paralyzed or killed in an accident if you ignore this warning.

TECHNICAL INFORMATION

Specifications

Item	Specification	
Model	Habit	Bad Habit
Wheel Size	XS: 27.5 in S-XL: 29 in	27.5+ in
Rear Travel	XS: 120 mm, S-XL: 130 mm	130 mm
Head Tube	UPR: 1 -1/8 in, LWR: 1-1/2 in	
Headset	Integrated, 1-1/8 in - 1-1/2 in	
Bottom Bracket: Type/ Width	CRB: PF30 / 83 mm, ALLY: BSA / 83 mm	
Front Derailleur	N/A	
Seat Post: Dia./Binder	31.6 mm / 34.9 mm	
▲ Min. Seat Post Insert	100 mm	
▲ Tire Size x Max. Width (measured)	XS: 27.5 in x 2.5 in S-XL: 29 in x 2.5 in	27.5 in x 2.8 in
▲ Max. Fork Length	551 mm	
Rear Shock: Eye-To-Eye / Stroke / Bushing Width	XS: 190 mm / 45 mm S-XL: 210 mm / 50 mm	
Recommended Sag (measured at shock)	25%, 11 mm	
Chain Guide	ISCG 05	
Rear Brake: Mount Type / Min/Max Rotor Dia.	Post Mount / 180 mm	
Rear Axle: Type/Length	Maxle TA / 148 x 12 mm, 180 mm Length	
Ai Offset:	Rear Wheel: 3mm Offset to NDS SRAM Chainring: +6 mm Offset Hollowgram SpideRing: Ai Offset	
▲ Intended Use	ASTM CONDITION 4, All-Mountain	
▲ Max. Weight Limit Total (rider+all equipment):	305 lbs / 138 kg	

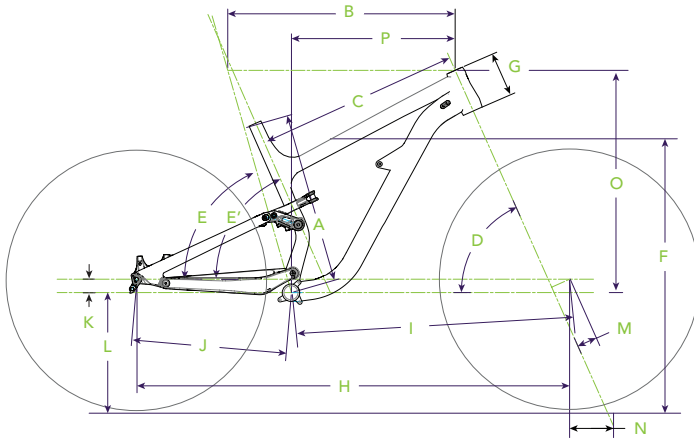

Dimensions = centimeter

Geometry - Habit

Frame Size	XS	S	M	L	XL
A Seat Tube Length	38	40	44	48	52
B Top Tube Horizontal	53.8	57.3	60.6	63.9	67.1
C Top Tube Actual	47.6	51	54.3	57.9	61.7
D Head Tube Angle	66°	*	*	*	*
E Seat Tube Angle	66.3°	*	*	*	*
E' Seat Tube Angle Effective	74.5°	*	*	*	*
F Stand Over	70	72	75	77	78
G Head Tube Length	9.5	10.5	11.5	12.5	13.5
H Wheel Base	110.3	114.4	117.6	121	124.4
I Front Center	67	71	74.3	77.8	81.1
J Chain Stay Length	43.5	*	*	*	*
K Bottom Bracket Drop	2.8	3.8	*	*	*
L Bottom Bracket Height	33.1	33.9	*	*	*
M Fork Rake	4.4	5.1	*	*	*
N Trail	11.2	*	*	*	*
O Stack	60	60.7	61.6	62.5	63.4
P Reach	36.6	40.0	43.0	46.0	49.0

All Specifications subject to change without notice.

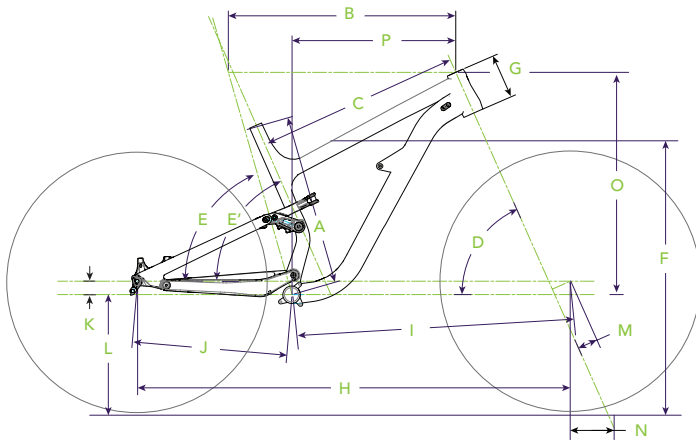

Dimensions = centimeter

Geometry - Bad Habit

Frame Size	S	M	L	XL
A Seat Tube Length	40	44	48	52
B Top Tube Horizontal	57.3	60.6	63.9	67
C Top Tube Actual	74.5°	*	*	*
D Head Tube Angle	66°	*	*	*
E Seat Tube Angle	66.3°	*	*	*
E ¹ Seat Tube Angle Effective	74.5°	*	*	*
F Stand Over	71.7	74.7	76.7	77.7
G Head Tube Length	10.5	11.5	12.5	13.5
H Wheel Base	114.6	118	121.4	124.7
I Front Center	71.3	74.7	78.2	81.4
J Chain Stay Length	43.4	*	*	*
K Bottom Bracket Drop	2.8	*	*	*
L Bottom Bracket Height	33.6	*	*	*
M Fork Rake	5.1	*	*	*
N Trail	10.6	*	*	*
O Stack	60.7	61.6	62.5	63.4
P Reach	40	43	46	49

All Specifications subject to change without notice.

Cable Guide - K32109

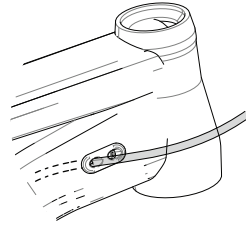

To remove:

1. Un thread the guide bolt using a 2.5mm allen before pushing on the bolt head to release the sliding part of the guide.

To install:

1. Route the housing or brake cable through the opening in the tube wall.
2. Slide the open cable guide over the exposed housing end.
3. Insert the cable guide into the frame. Use a 2.5mm allen key to push on the bolt head to ease installation.
4. Pull the excess housing slack out of the frame.
5. Tightening the guide bolt until the cable no longer moves. Do not over-tighten.

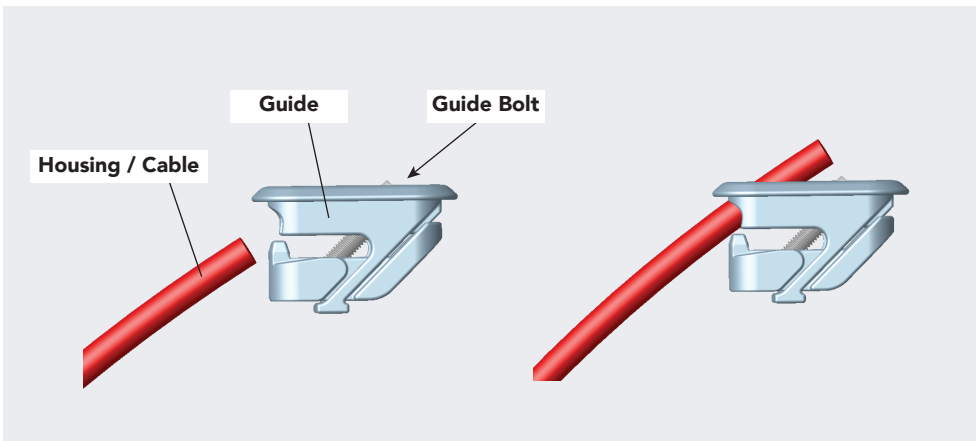

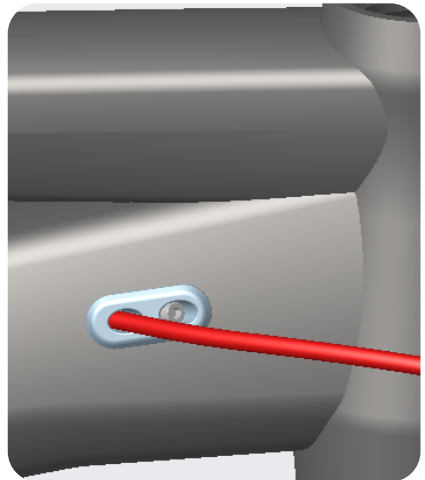
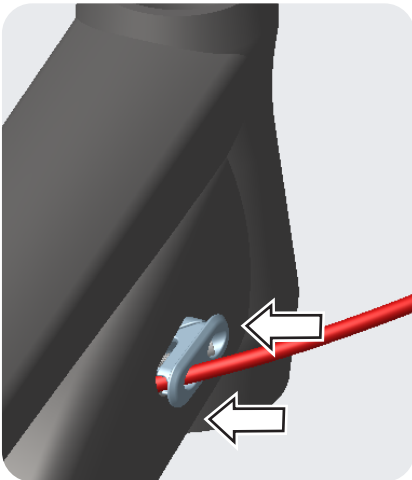
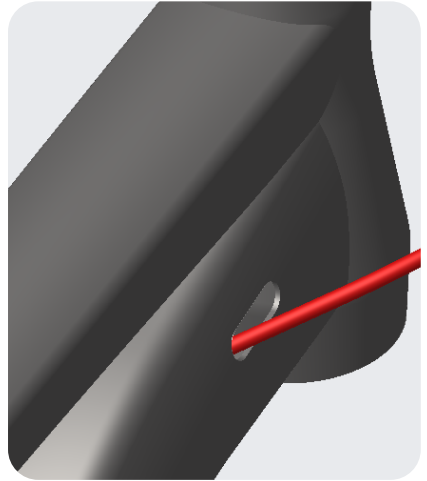
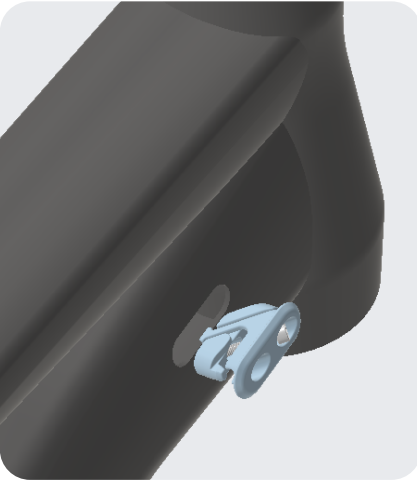

To insert in frame opening, press both inward on the guide bolt with the tool end and on the housing side.

NOTE: Pulling the slack from the frame, before tightening the guide bolt will reduce cable rattle.

Cable Routing: Alloy Chainstay

To route shift housing through the alloy chainstay:

1. Form a loop of housing by the bottom bracket as shown A. This will help with pushing the housing into the chainstay.
2. Using pliers, add a slight bend to the end of the housing to ease installation.
3. Insert the housing into the chainstay opening. Push the loop of cable until the housing end exits the chainstay, shown B.
4. Continue pushing the housing until the housing enters the chainstay tube, shown C.
5. Remove the rear chainstay pivot hardware to access the rear opening of the chainstay.
6. While pushing the housing from the front of the chain stay, guide the housing up through the routing hole using a pick. To ease installation, use pliers to give the end of the housing a slight bend.

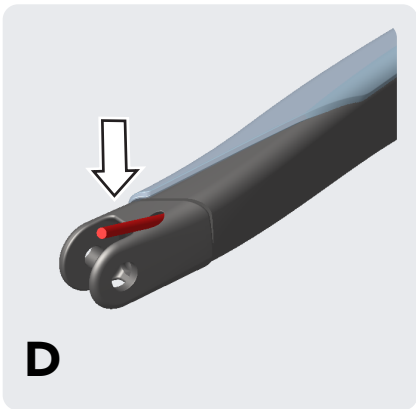
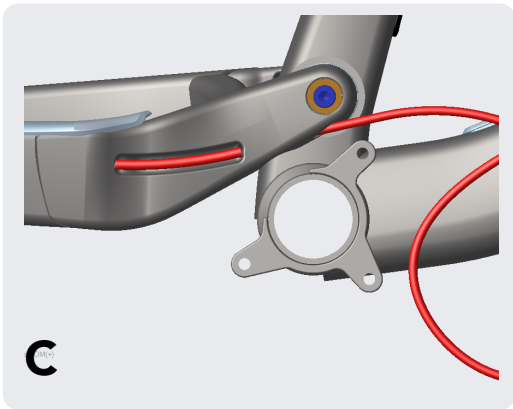
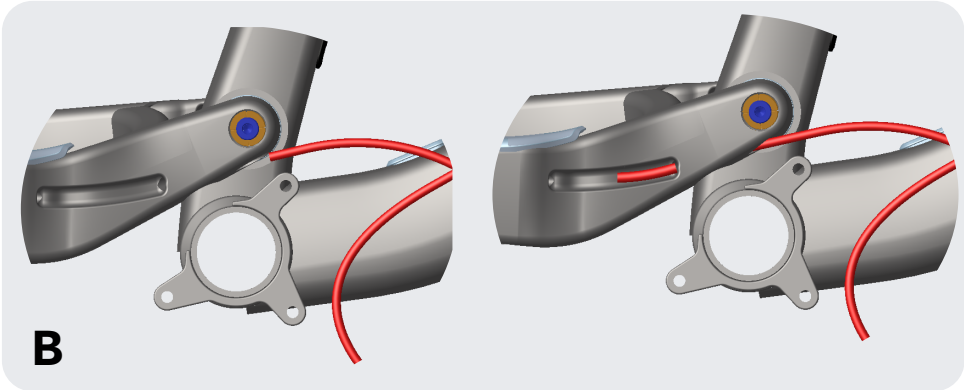
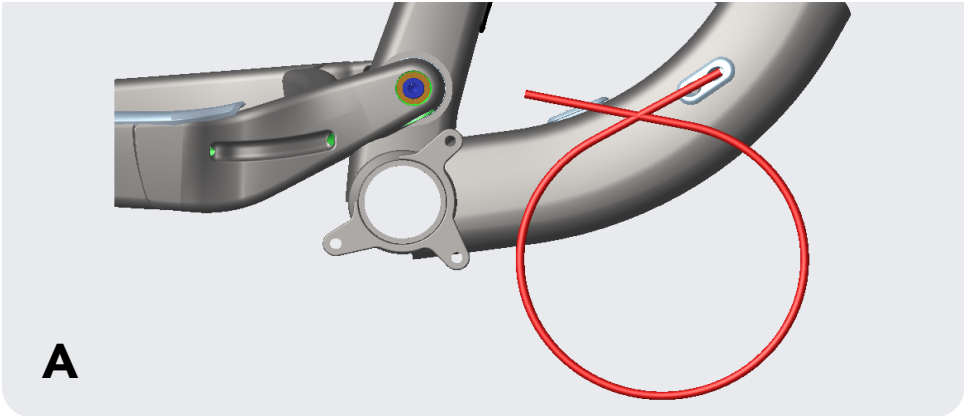

Cable Routing: Carbon Front Triangle

The carbon Habit Front triangle features internal tubing to ease cable routing. Please see the below diagram to see entry/exit points and recommended uses. An internal tube is not present in the lower head tube opening on the non-drive side, shown as SR below.

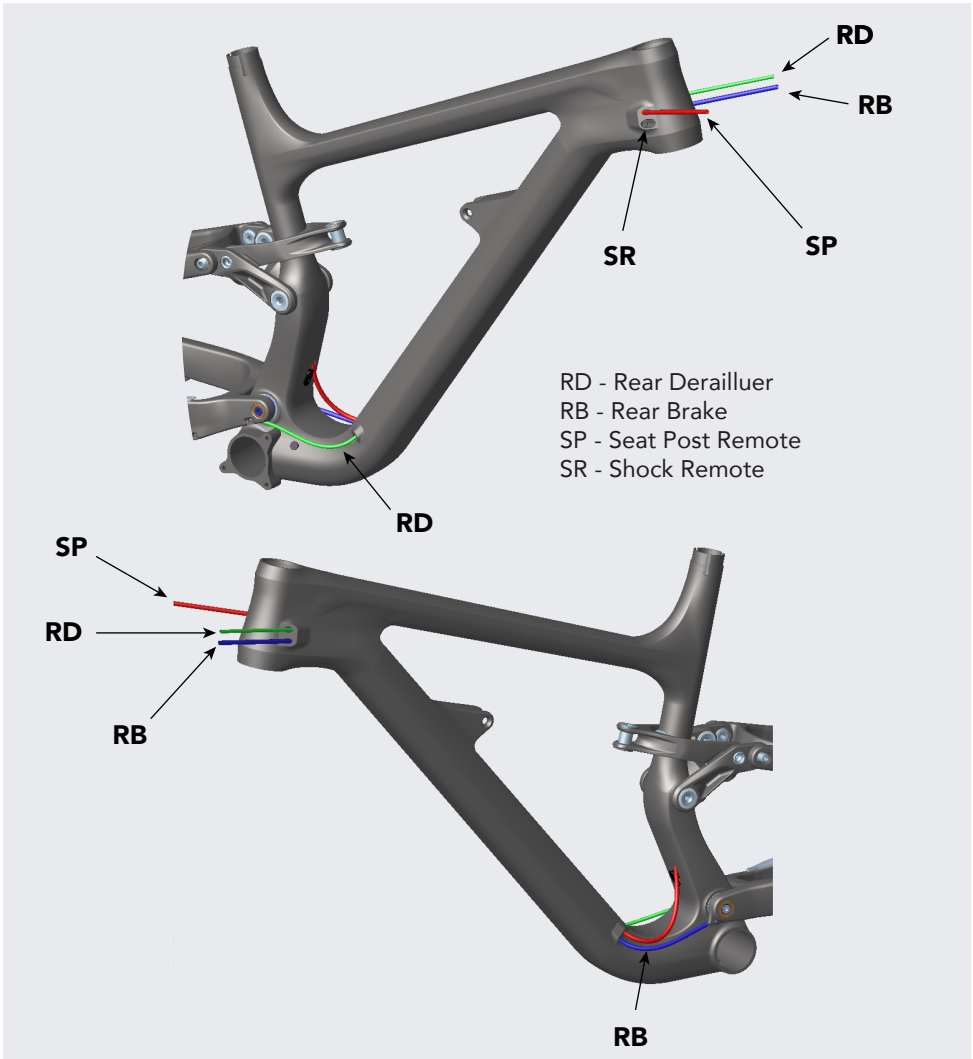

Cable Routing: Carbon Chain Stay

To route the shift housing:

1. Insert the housing into the chainstay routing port shown, A.
2. Remove the rear chainstay pivot hardware to access the rear of the chainstay.
3. While pushing the housing from the front of the chain stay, guide the housing up through the routing hole using a pick. To ease installation, use pliers to give the end of the housing a slight bend, shown B.
4. Secure the forward end of the housing using two zip ties, shown C.

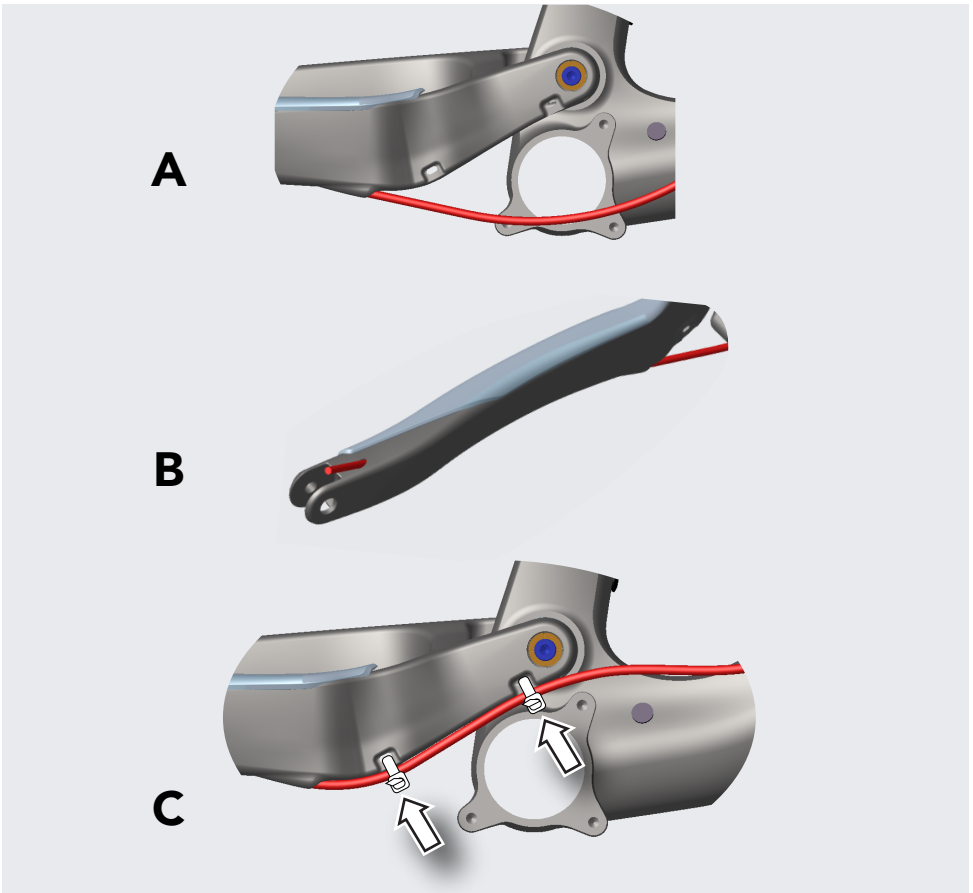

Size Specific Yokes

The Habit features size specific yoke lengths. Please see the table below to check the proper yoke length for each frame size. Please check underneath the yoke for length markings.

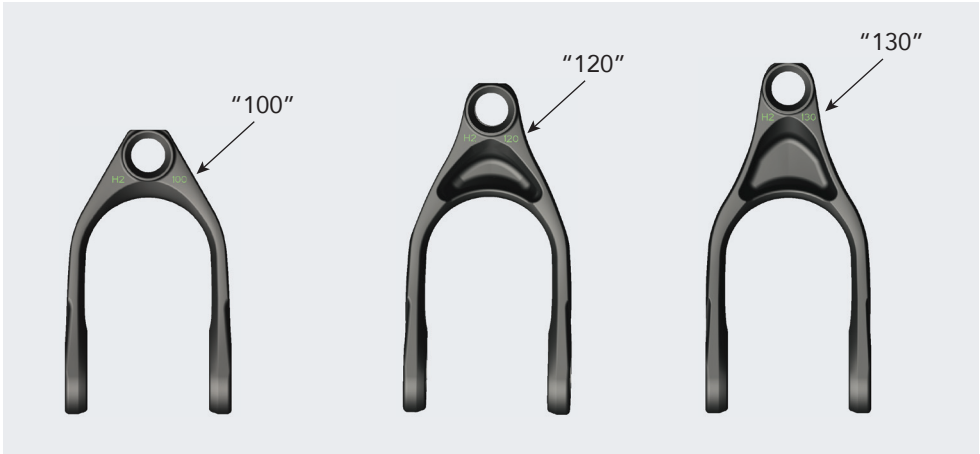

Frame Size	Yoke Length
XS	100 mm
S	100 mm
M	100 mm
L	120 mm
XL	130 mm

Yoke

Whenever a shock is installed in the yoke extension, ensure that darker shaded areas shown below are clean and thoroughly greased with a high-quality bearing grease.

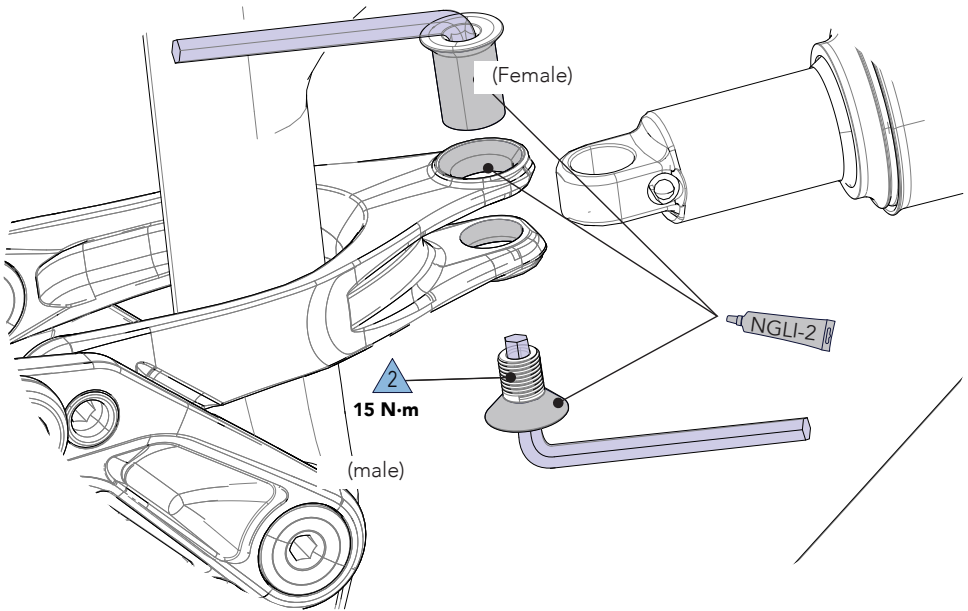

NOTE: When tightening, insert tool into and hold female bolt, turn bolt to avoid scuffing the female bolt.

Frame Assembly

IMPORTANT: During assembly of the rear suspension pivots on all frame sizes, tighten the yoke to shock bolt last.

Use the following method to assemble the shock yoke on the XS size habit:

1. Assemble all components of the frame, leaving the shock and yoke extension unattached. Allow the suspension to rest under gravity.
2. Assemble the shock using the forward eyelet (frame side).

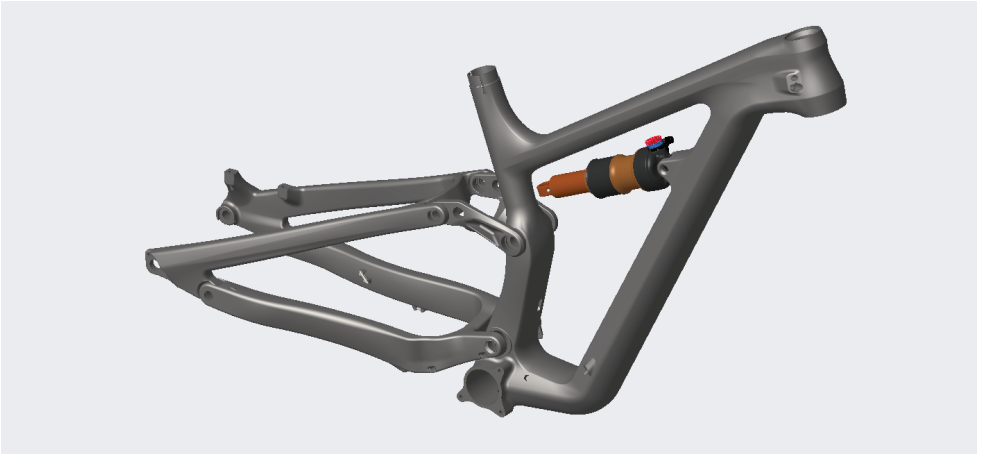

3. Assemble the shock yoke 90 from the side of the ST.
4. Rotate the yoke around the seat tube until it is inline with the rear shock eyelet and install the shock-yoke bolt loosely.
5. Assemble the yoke to link hardware before tightening the shock-yoke bolt to torque.

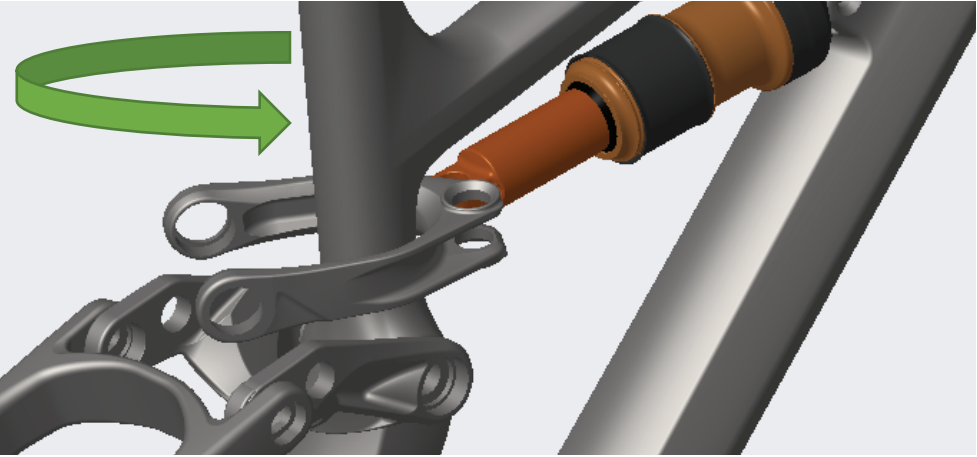
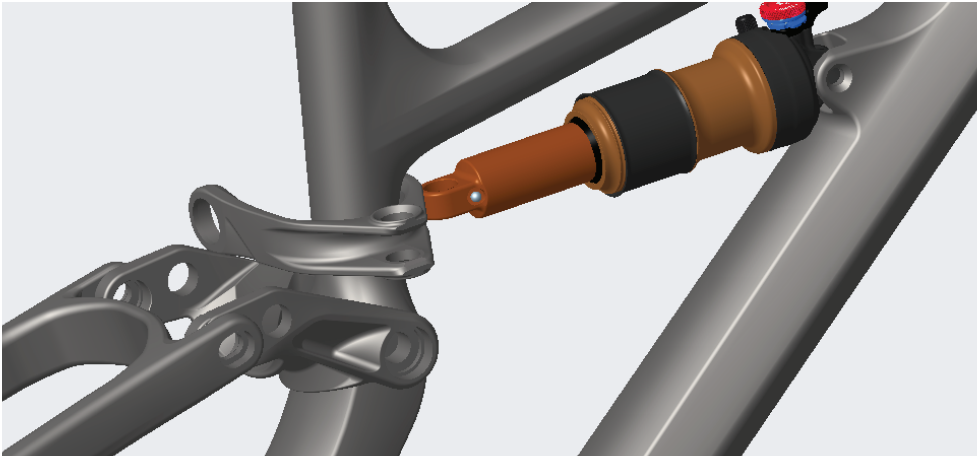

Habit Flip Chip

The Habit and Bad Habit feature a flip chip enabling geometry adjustment.

- **Low** - slacker head tube angle (-0.5°), lower bottom bracket height (-3 mm), and reach (-3 mm).
- **High** - steeper head tube angle (+0.5°), higher bottom bracket height (+3 mm), and reach (+3 mm)

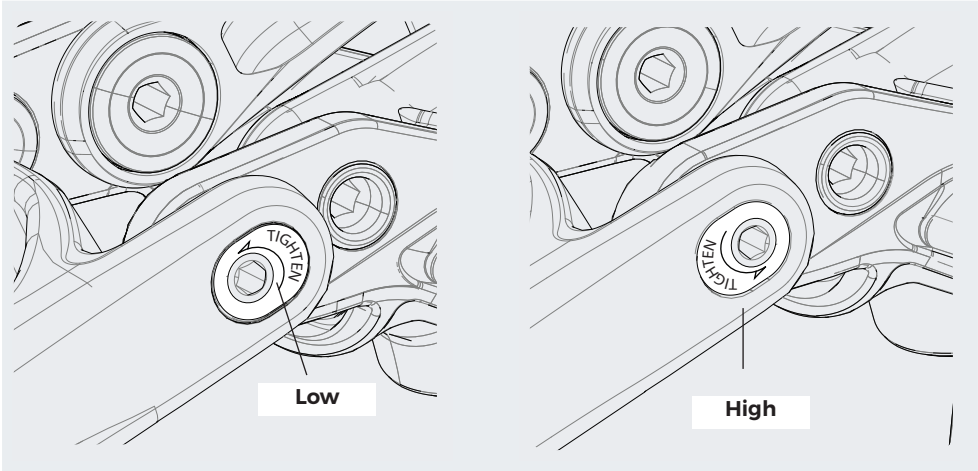

Model	Habit		Bad Habit
Wheel Size	27.5 in	29 in	27.5+ in
Standard* Flip Position	High	Low	High
Alternate Flip Position	Low	High	Low

* In the Standard Flip Chip position, the geometry of the bike is shown on the Geometry tables on pages 8 and 9.

NOTE: Insert the hex tool completely into the flip chip to turn.

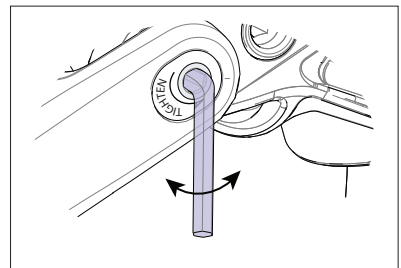

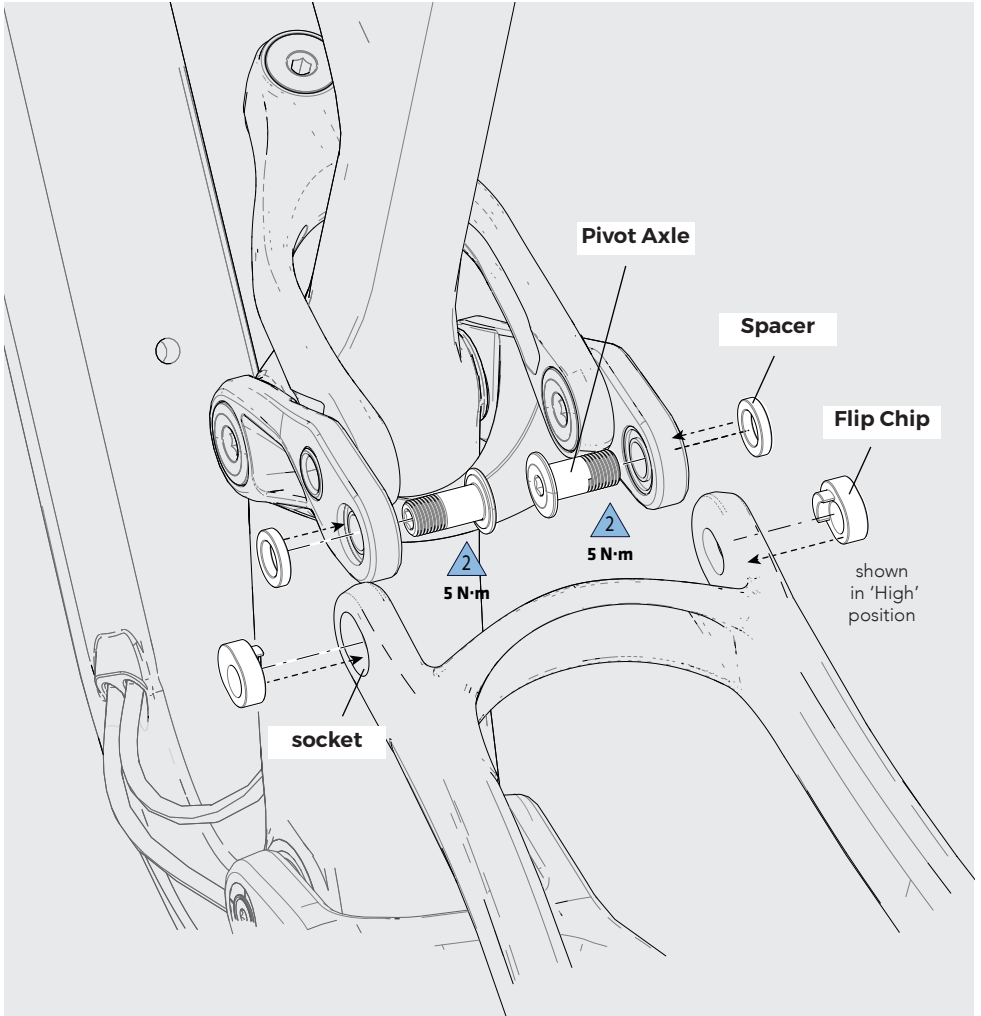

IMPORTANT: Whenever a change is made to the Flip Chip position, make sure the hardware, flip chips, and seat stay sockets are wiped clean. Re-apply the specified thread lock to the bolt threads and tighten to the specified torque.

Dropouts

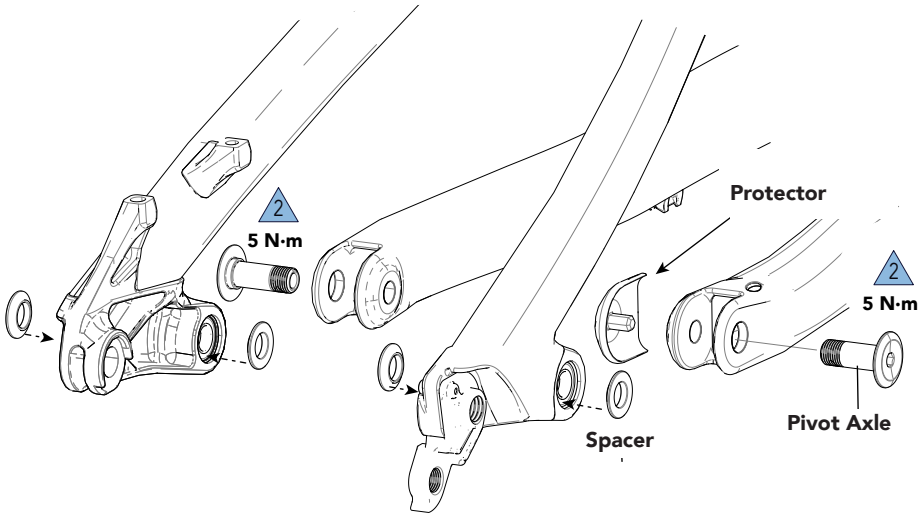

- When connecting the seat stays to the chain stay, make sure the small end of spacers face the bearings . The flat side of the spacers should face out, as shown.
- When tightening the axles, insert the 5 mm hex key completely into the axle to prevent damage when turning the bolt.
- Always clean and re-apply the specified thread lock to the bolt threads.
- Tighten with a torque wrench to the specified torque.

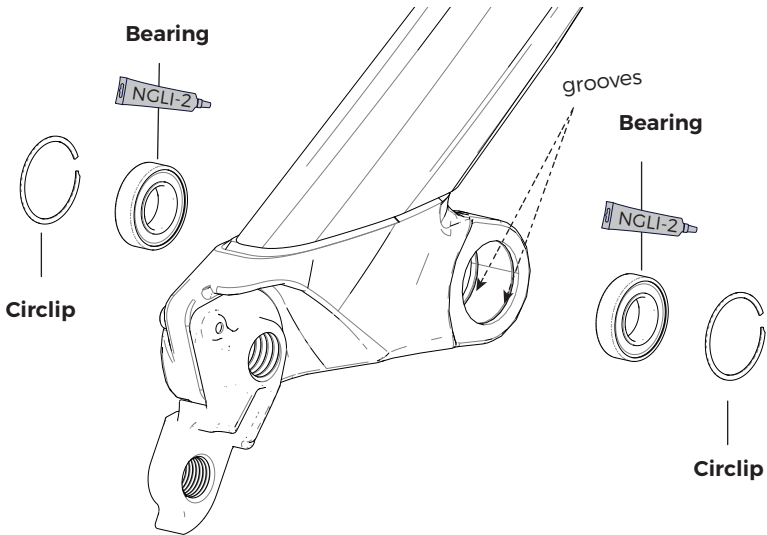

- The condition of the bearings, pivot axles, and spacers should be inspected periodically. These are normal wear parts so plan to have them replaced as they wear-out.
- To inspect the bearings, remove the pivot to expose the bearings. There are two bearings in each dropout. Rotate each bearing with your finger. The rotation should feel smooth without binding. Each bearing should be fixed securely in the opening. Check to make sure each circlip is seated in the groove.s
- Inspection frequency should be based upon how and where you ride. Evidence of damage would be excessive play, visible wear, or corrosion of bearings.
- If you find any damage to the parts, discontinue riding until all the parts (bearings, pivot axles, spacers) can be replaced. This will help prevent damage elsewhere.
- Do not re-use removed bearings; if removed replace all bearings with new ones.

LockR

Be sure to support the bike or swingarm to prevent personal injury or bike damage when removing/disconnecting linkages of an axle.

To remove the LockR from the frame:

1. Loosen the screw 4-6 turns using a T25 Torx key.
2. Tap head of screw with a rubber mallet to un-seat the wedge bolt located on the opposite side..
3. Remove the screw and wedge bolt from the still installed axle.
4. If it did not come out with the screw, insert a 5 mm hex key and turn to free and remove it. If wedge still sticks insert a wooden or plastic dowel into the drive side and drive it out.
5. To remove the axle itself, on non-drive side, insert a 6 mm hex key into the axle on the non-drive side and and turn counter-clockwise until it can be removed.

To install the LockR from the frame:

1. Disassemble and clean all parts of the LockR axle. Do not install it assembled. Inspect the parts for damage (burrs, scratches, deformity, wear). Replace the entire LockR assembly if any damage is found.
2. Apply a light coating of a high-quality bicycle bearing grease to all parts.
3. Align the linkage and bearing and insert the threaded end of the pivot axle (1) into the non-drive side.
4. Tighten the inserted pivot axle to 1 Nm using a 6 mm hex key fitted torque wrench from the non-drive side.

NOTICE

Use a calibrated torque wrench. Exceeding 1 N·m will result in permanent damage to the LockR pivot system.

5. Insert the wedge bolt (2) into the drive side of the axle and insert the small end of the wedge (3) into the non-drive side axle head.
6. Thread the screw (4) into wedge bolt with a wrench and tighten to 5.0 Nm.

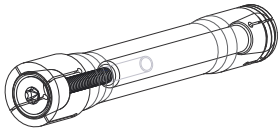

DO NOT INSTALL ASSEMBLED

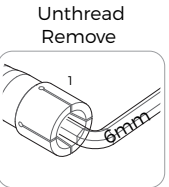
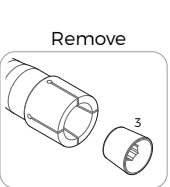
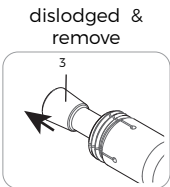
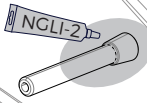
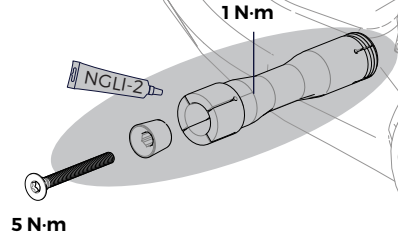
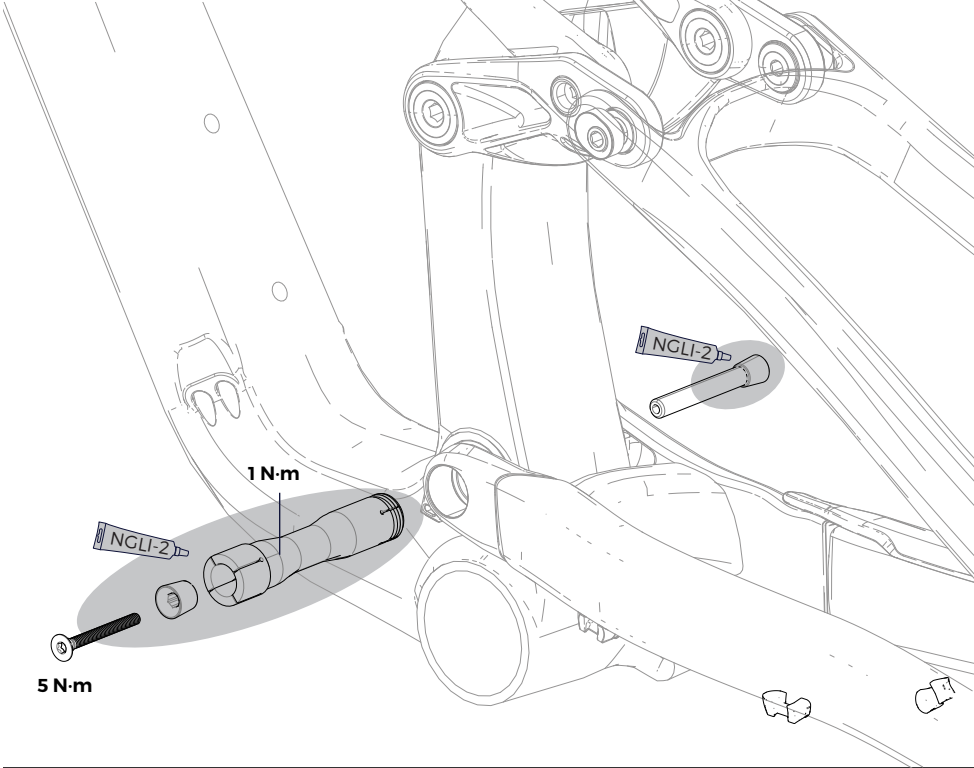

Asymmetric Integration - Ai

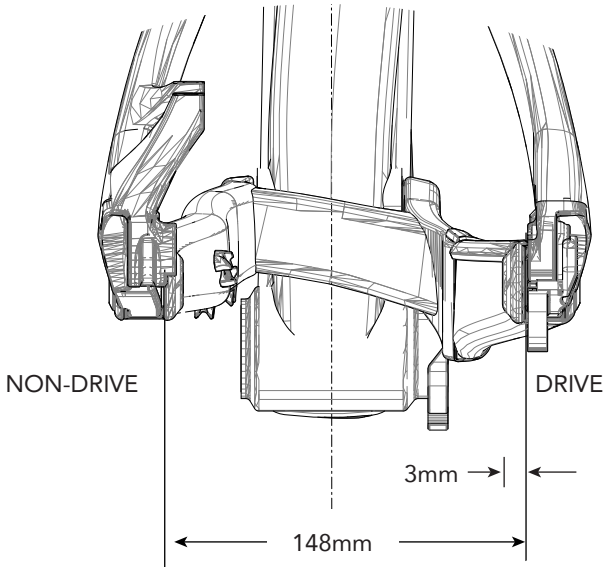

The Ai rear hub is offset 3 mm to the drive side. This both aligns the cassette with the Ai frame's 55mm chainline, and aligns the rim/tire with frame's centerline for correct tire clearance.

Ai wheels have equal spoke angles and tension on both sides (non-dished wheel) which improves wheel stiffness, strength.

- **The 3mm offset is for 148 X 12mm spacing only!**
- **Other Ai equipped bike with 142mm or 135mm rear spacing use a 6mm offset.**

NOTICE

USE ONLY 3mm "Ai" OFFSET REAR WHEELS. Incorrect wheel offset can damage your frame. Standard wheel assembled on this frame will result in insufficient tire clearance leading to rubbing and serious frame damage. This kind of damage is not covered by the Cannondale Limited Warranty.

Building/Truing a Wheel

If you chose to build, or true the wheel, make sure the 3 mm offset is present. Consult with your Cannondale Dealer if you have any questions.

Hanger Replacement

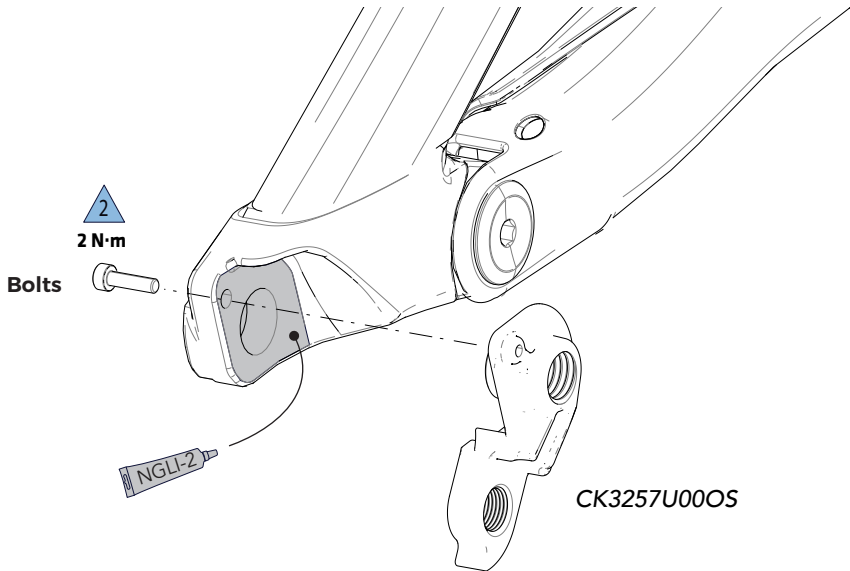

- Before installing a new hanger, be sure to clean any dirt or debris on the dropout with a nylon brush (old toothbrush).
- Inspect the area for any damage.
- Lightly grease the dropout surface.
- Always clean and re-apply the specified thread lock to the bolt threads.
- Tighten with a torque wrench to the specified torque.

REPLACEMENT PARTS

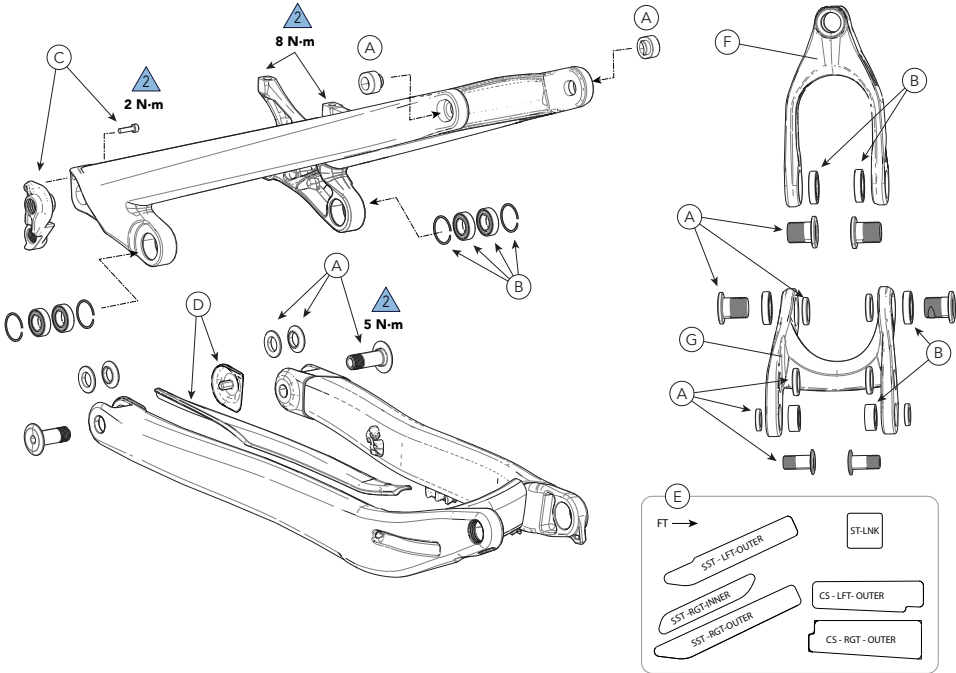

ID	Part Number	Description	CRB	ALLY
A	K36169	Habit Pivot Hardware	✓	✓
B	K36179	Habit Pivot CS SS LNK Brgs	✓	✓
C	CK3257U00OS	Derailleur Hanger TA ST SS 015	✓	✓
D	K34129	CS and Horst Pivot Protectors	✓	✓
E	K34239	Habit CS SS ST Clear Protectors	✓	✓

ID	Part Number	Description	CRB	ALLY
F	K36109	Habit Yoke XS-M BLK	✓	✓
	K36099	Habit Yoke L BLK	✓	✓
	K36089	Habit Yoke XL BLK	✓	✓
G	K91069	Habit Suspension Link BLK	✓	✓

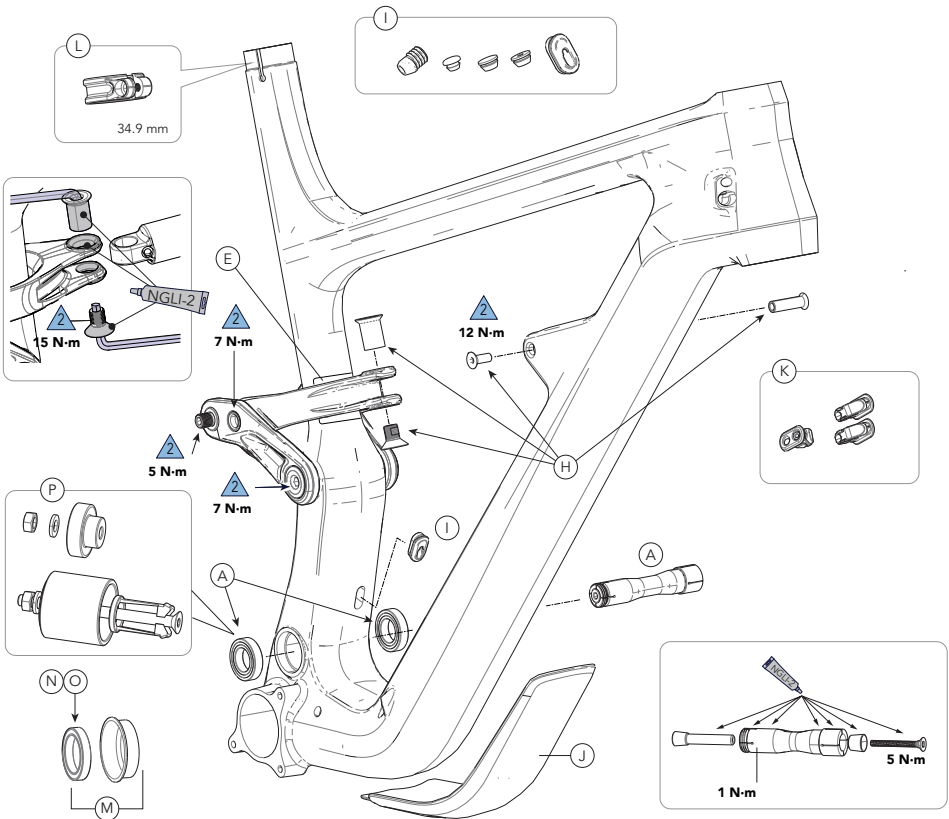

ID	Part Number	Description	CRB	ALLY
H	K36079	Habit Shock Bolts	✓	✓
I	K32069	Habit CRB Rubber Frame Grommets	✓	
J	K34139	Habit DT Protector XS-S	✓	✓
	K34149	Habit DT Protector M-XL	✓	✓
K	K32109	Slide Guides (QTY 6)		✓
L	KP388/	Seat Binder MTN Bolt 34.9	✓	✓

ID	Part Number	Description	CRB	ALLY
M	KP197/SRM	PF30 Bottom Bracket Cups And Bearings	✓	
N	KB6180/	BB30 Bearing Blue (QTY 2)	✓	
O	K22037	BB30 Bearing Blue (QTY 24)	✓	
P	CK9017U00OS	17X30 Bearing Tool	✓	✓

Tightening Torques

Correct tightening torque for the fasteners (bolts, screws, nuts) on your bicycle is very important to your safety, durability, and performance of your bicycle.

We urge you to have your dealer correctly torque all fasteners using a torque wrench. If you decide to tighten fasteners yourself always use a calibrated torque wrench!

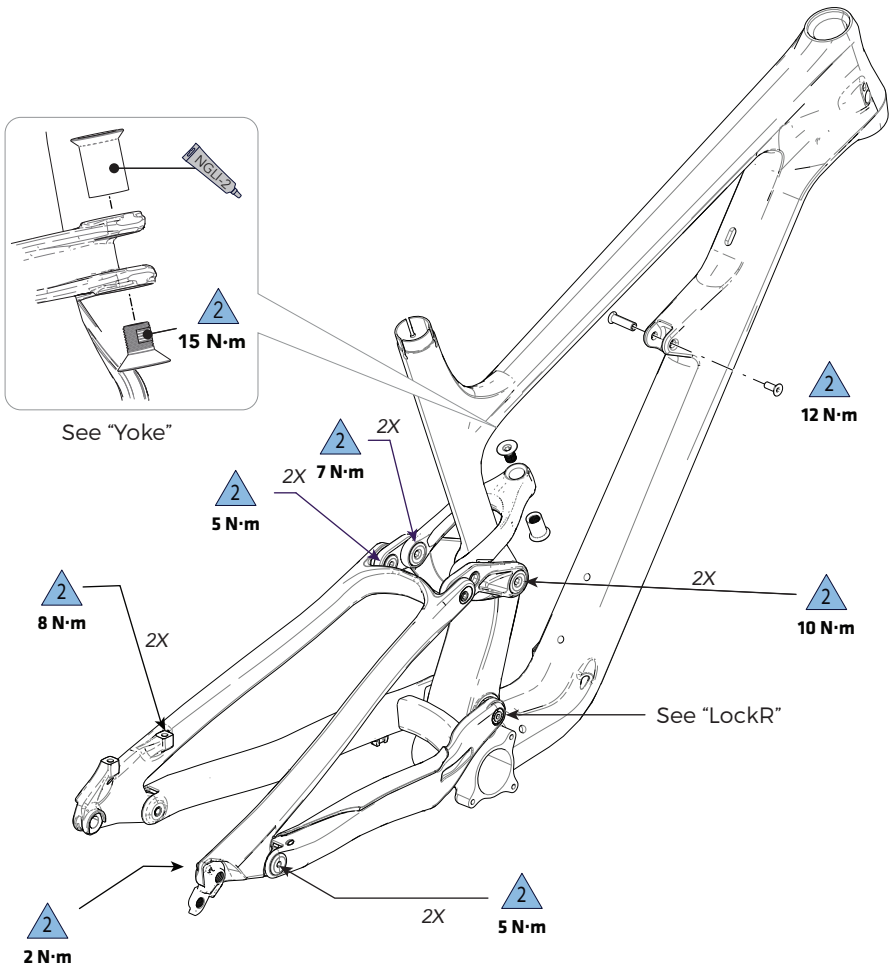

MAINTENANCE

The following table lists only supplemental maintenance items. Please consult your [Cannondale Bicycle Owner's Manual](#) for more information on basic bike maintenance.

Item	Frequency
<p>Cable Routing - Make sure control cables are in place, undamaged and attached securely.</p> <p>Frame Protection - Check the various frame protectors (downtube, headtube, chainstay, swingarm on your bike. Make sure they are in place and in good condition.</p>	Before first ride
<p>Damage Inspection - Clean and visually inspect entire bike frame/swing arm/linkage assembly for cracks or damage.</p>	Before and after each ride
<p>Check Tightening Torques - In addition to other component specific tightening torques for your bike. tighten according to the "Tightening Torques" information listed in this supplement.</p>	Every few rides
<p>Disassemble, clean, inspect, re-grease, replace worn or damaged parts in the following assemblies:</p> <ul style="list-style-type: none"> · Shock Link/Yoke · Pivot Axles · Frame Pivot Bearings 	<p>In wet, muddy, sandy conditions every 25 hrs.</p> <p>In dry, conditions every 50 hrs.</p>
<p>Fork and Shock- Consult the manufacturer's owner's manual for maintenance requirements.</p>	

WARNING

Any part of a poorly maintained bike can break or malfunction leading to an accident where you can be killed, severely injured or paralyzed.

Frequent checks are necessary to identify the problems that can lead to an accident. See "Inspect For Safety" in your [Cannondale Bicycle Owners Manual](#).

WWW.CANNONDALE.COM

© 2018 Cycling Sports Group
Habit Owner's Manual Supplement
134938 Rev. 1



CANNONDALE USA

Cycling Sports Group, Inc.
1 Cannondale Way,
Wilton CT, 06897, USA
1-800-726-BIKE (2453)
www.cannondale.com

CANNONDALE EUROPE

Cycling Sports Group Europe, B.V.
Hanzepoort 27, 7570 GC, Oldenzaal,
Netherlands +41 61 4879380
servicedeskeurope@cyclingsportsgroup.com

CANNONDALE UK

Cycling Sports Group
Vantage Way, The Fulcrum,
Poole, Dorset, BH12 4NU
+44 (0)1202732288
sales@cyclingsportsgroup.co.uk