

RECREATION / URBAN

> FITNESS, FUNCTION AND FUN.

We're passionate about creating the perfect ride for every kind of rider. The high performance, fit and style of our Recreation and Urban bikes will inspire you to get fitter, commute more and spend more time on two wheels.



> URBAN

Sleek, stylish and functional, these bikes are high-tech urban mobility.

BAD BOY
HOOLIGAN

> RECREATION

Light, comfortable, friendly bikes for fitness, commuting and adventure.

QUICK
QUICK CX
ADVENTURE

BAD BOY

> URBAN. LEGEND.

Like a stealth fighter with 700c wheels, the **Bad Boy** is a fast, stylish, functional, high-tech way to get around the city. Faster than the subway, cooler than a cab, **Bad Boy** adds an edgy thrill to every urban journey.



> UNIQUE FORK OPTIONS

The radical-looking, lightweight single-bladed **HeadShok Solo DL50** offers 50mm of fluid travel, hydraulic damping and convenient lockout, while the non-suspension **Solo** or **Fatty** rigid forks are super light and precise-handling.



> RIDER TAILORED GEOMETRY

Bad Boy, not surprisingly, has some attitude in its more-aggressive-than-most urban geometry. Its position and angles deliver quick responsiveness, while still giving good rider visibility in traffic.



> SAVE CHAIN STAYS

Optimized chain stay shaping adds vertical compliance for bump absorption and comfort with no loss in power transfer.



C13BB1 BAD BOY 1

FRAME	BAD BOY STEALTH, HEADSHOK, OPTIMIZED 6061 ALLOY
FORK	HEADSHOK SOLO DL50, 50MM W/ LOCKOUT, OPI
TIRES	WTB FREEDOM THICKSLICK, 700X28C

CRANKS	FSA COMET 42/32/24
DERAILLEURS R/F	SHIMANO SLX / DEORE
SHIFTERS	SHIMANO DEORE

BLACK ANODIZED W/ REFLECTIVE DECALS, MATTE (BBQ)

HANDLEBAR/STEM	URBAN OPI STEM/HANDLEBAR W/ SI LIGHT
BRAKES	MAGURA MT2 HYDRAULIC DISC
SIZES	S, M, L, X

Also see Bad Girl in the Women's section



C13BB5

BAD BOY 5

FRAME	BAD BOY, 1.5" HT, OPTIMIZED 6061 ALLOY
FORK	CANNONDALE SOLO RIGID, OPI, 1.5"
TIRES	WTB FREEDOM THICKSLICK, 700X28C

CRANKS	SHIMANO M431, BAD BOY, 48/36/26
DERAILLEURS R/F	SHIMANO DEORE / ALIVIO
SHIFTERS	SHIMANO ALIVIO

JET BLACK W/ REFLECTIVE DECALS, MATTE (BBQ)

HANDLEBAR/STEM	URBAN OPI STEM/HANDLEBAR W/ SI LIGHT
BRAKES	SHIMANO M395 HYDRAULIC DISC
SIZES	S, M, L, X



C13BB9

BAD BOY 9

FRAME	BAD BOY, OPTIMIZED 6061 ALLOY
FORK	CANNONDALE FATTY RIGID
TIRES	WTB FREEDOM THICKSLICK, 700X28C

CRANKS	SHIMANO M171, 48/38/28
DERAILLEURS R/F	SHIMANO ALIVIO / ALTUS
SHIFTERS	SHIMANO M310 RAPIDFIRE PLUS

JET BLACK W/ REFLECTIVE DECALS, MATTE (BBQ)

HANDLEBAR/STEM	CANNONDALE C4
BRAKES	TEKTRO NOVELA MECHANICAL DISC
SIZES	S, M, L, X

HOOLIGAN

> JUNGLE. GYM.

A fun, funky and functional answer to the demands of the urban jungle, the **Hooligan's** stout frameset and snappy handling make it a blast to rip through city streets, and its compact size and little wheels make it easy to carry up to that 4th floor walk-up.



> 20" WHEELS

20" wheels accelerate faster and, combined with a lower standover height, make this a more compact, easily stored bike for the small apartment confines of the city.



> DELTA V FRAME

Unlike flimsy, poor-handling folding bikes, the **Hooligan's Delta V** frame configuration is super strong and stiff for precise handling and confidence, yet provides excellent standover clearance.



> LEFTY SOLO FORK

Forged from a single piece of aluminum, the radical single-sided fork not only looks cool, but is extremely stiff and strong thanks to its **OPI** one-piece construction.



C13HL1

HOOLIGAN 1

FRAME	HOOLIGAN DELTA V, URBAN COMPACT, 20" WHEEL
FORK	CANNONDALE SOLO RIGID, OPI, 1.5"
TIRES	KENDA QUEST, 20 X 1.5"

CRANKS	FSA VERO, SINGLE RING, DUAL ALLOY CHANGUARD, 48T
DERAILLEURS R/F	N/A
SHIFTERS	SHIMANO NEXUS REV0 3-SPEED

JET BLACK, MATTE (BBQ)

HANDLEBAR/STEM	CANNONDALE URBAN / C3 ADJUSTABLE
BRAKES	SHIMANO M375 MECHANICAL DISC, 160/160MM
SIZES	ONE SIZE

QUICK

> OUTDOOR HEALTH CLUB.

The **Quick** line blends speed, performance, comfort and convenience in a combination that is just right for fun, fitness and exploration. Whether you choose the exotic **Quick Carbon**, the lightweight **Quick SL** or the smooth and simple **Quick**, you'll find that on a **Quick**, you go a little faster, ride a little further, and push yourself a little harder than you ever thought possible.



C13QRC1

QUICK CARBON 1

FRAME	QUICK FULL CARBON, W/ SAVE FEATURES
FORK	QUICK SI, FULL CARBON
TIRES	SCHWALBE MARATHON SUPREME, 700X28C

CRANKS	FSA SLK CARBON, BB30, 50/34
DERAILLEURS R/F	SHIMANO 6700 ULTEGRA
SHIFTERS	SHIMANO TIAGRA

RAW MATTE CARBON (CRB)

HANDLEBAR/STEM	CANNONDALE C2
BRAKES	TEKTRO CX9 MINI V, CNC
SIZES	S, M, L, X, J

> RIDER TAILORED GEOMETRY - QUICK

For **Quicks**, "Rider Tailored Geometry" means a balance of an efficient, sporty position with the confidence and comfort of heads-up riding.

> CUSTOM FORKS

Each **Quick** is paired with Cannondale fork designed specifically for the frame, for a seamless look and great handling.

> COMFORT FEATURES

All **Quicks** have **SAVE** features in the rear triangle to absorb shock, soft-grip flat pedals and ergonomic grips and saddle for comfort.

See also Women's Quick SL and Quick



C13QRC2

QUICK CARBON 2

FRAME	QUICK FULL CARBON, W/ SAVE FEATURES
FORK	QUICK SI, FULL CARBON
TIRES	KENDA KWICK, 700X28C

CRANKS	FSA OMEGA, BB30, 50/34
DERAILLEURS R/F	SRAM APEX
SHIFTERS	SRAM X5

RAW MATTE CARBON (CRB)

HANDLEBAR/STEM	CANNONDALE C3
BRAKES	CANNONDALE, MINI V
SIZES	S, M, L, X, J



C13QR1

QUICK SL 1

FRAME	QUICK SL BB30, OPTIMIZED 6061 ALLOY, SAVE
FORK	QUICK SI, CARBON BLADES
TIRES	KENDA KWICK ROLLER SPORT 700X32C

CRANKS	FSA GOSSAMER COMPACT BB30 50/34
DERAILLEURS R/F	SHIMANO 105 5700 / TIAGRA
SHIFTERS	SHIMANO TIAGRA 4600, RAPIDFIRE PLUS

BRUSHED ALUMINUM, GLOSS (RAW)

HANDLEBAR/STEM	CANNONDALE C3
BRAKES	CANNONDALE C2 MINI V, CARTRIDGE PADS
SIZES	S, M, L, X, J



C13QR2

QUICK SL 2

FRAME	QUICK SL BB30, OPTIMIZED 6061 ALLOY, SAVE
FORK	QUICK SL, CARBON BLADES
TIRES	KENDA KWICK ROLLER SPORT 700X32C

CRANKS	FSA OMEGA, BB30, 50/34
DERAILLEURS R/F	SHIMANO SORA / R443
SHIFTERS	SHIMANO SORA, RAPIDFIRE PLUS

JET BLACK, MATTE (BBQ)

HANDLEBAR/STEM	CANNONDALE C4
BRAKES	CANNONDALE C2 MINI V, CARTRIDGE PADS
SIZES	S, M, L, X, J



MAGNESIUM WHITE, GLOSS (WHT)



C13QR3

QUICK SL 3

FRAME	QUICK SL, OPTIMIZED 6061 ALLOY, SAVE
FORK	QUICK SL, CARBON BLADES
TIRES	KENDA KWICK BITUMEN 700X32C

CRANKS	FSA ALPHA DRIVE, 48/36/26
DERAILLEURS R/F	SHIMANO DEORE / ALIVIO
SHIFTERS	SHIMANO ALIVIO RAPIDFIRE PLUS

40 BLUE, GLOSS (BLU)

HANDLEBAR/STEM	CANNONDALE C4
BRAKES	CANNONDALE C3 MINI V, CARTRIDGE PADS
SIZES	S, M, L, X, J



C13QR4

QUICK 4

FRAME	QUICK, BUTTED 6061 ALLOY, SAVE
FORK	QUICK, CARBON BLADES
TIRES	KENDA KWICK TRAX, 700X32C (26X1.5" ON XS)

CRANKS	SHIMANO M171, 48/38/28
DERAILLEURS R/F	SHIMANO ALIVIO / M191
SHIFTERS	SHIMANO M310 RAPIDFIRE PLUS



JET BLACK, GLOSS (BLK)

FINE SILVER, GLOSS (SLV)

HANDLEBAR/STEM	CANNONDALE C4
BRAKES	CANNONDALE C4 MINI V
SIZES	XS (26" WHEELS), S, M, L, X, J



C13QR5

QUICK 5

FRAME	QUICK, BUTTED 6061 ALLOY, SAVE
FORK	QUICK, 6061 ALLOY
TIRES	KENDA KWICK TRAX, 700X32C

CRANKS	SHIMANO M131, 48/38/28
DERAILLEURS R/F	SHIMANO ALTUS / M191
SHIFTERS	SHIMANO M310 RAPIDFIRE PLUS



MAGNESIUM WHITE, GLOSS (WHT)

BERSERKER GREEN, GLOSS (GRN)

HANDLEBAR/STEM	CANNONDALE C4
BRAKES	CANNONDALE C4 MINI V
SIZES	S, M, L, X, J



C13QR6

QUICK 6

FRAME	QUICK, BUTTED 6061 ALLOY, SAVE
FORK	QUICK, CROMOLY
TIRES	KENDA KOURIER, 700X32C

CRANKS	SHIMANO M131, 48/38/28
DERAILLEURS R/F	SHIMANO ALTUS / M191
SHIFTERS	SHIMANO EASYFIRE

JET BLACK, MATTE (BBQ)

HANDLEBAR/STEM	CANNONDALE C4
BRAKES	CANNONDALE C4 MINI V
SIZES	S, M, L, X, J

QUICK CX

> SPORT. UTILITY.

On-road efficiency meets off-road ruggedness. From the fire roads of Big Sur to the cobbles of SoHo, the **Quick CX's** mountain-bike inspired frame, 700c knobby tires, front suspension, and disk brakes make it the perfect vehicle for dirt road adventuring, off-road shortcuts through the park or all-weather commuting.



C130X1
QUICK CX 1

FRAME	QUICK CX HEADSHOK, OPTIMIZED 6061 ALLOY, SAVE
FORK	HEADSHOK FATTY DL50, 50MM W/ LOCKOUT, OPI
TIRES	KENDA HAPPY MEDIUM, 700X35C

CRANKS	SHIMANO M521, 48/36/26
DERAILLEURS R/F	SHIMANO SLX / ALIVIO
SHIFTERS	SHIMANO DEORE

BRUSHED ALUMINUM, GLOSS (RAW)

HANDLEBAR/STEM	CANNONDALE C3
BRAKES	MAGURA MT2 HYDRAULIC DISC
SIZES	S, M, L, X, J

> RUGGED FORKS

For off-road control and on-road comfort, most **Quick CXs** are equipped with 50mm-travel, 1.5" steerer suspension forks, including the radically light and stiff **HeadShok DL50**.

> DISK BRAKES

Disk brakes add all-weather braking power and control.

> RACK AND FENDER READY

With rack and fender mounts, including low-rider fork mounts, the **Quick CX** is ready for anything from commuting to fully loaded overnight adventures.

See also Althea



C130X2
QUICK CX 2

FRAME	QUICK CX, 1.5" HT, OPTIMIZED 6061 ALLOY, SAVE
FORK	RST NEON PLS 1.5" TNL, 50MM W/ LOCKOUT
TIRES	KENDA HAPPY MEDIUM, 700X35C

CRANKS	SHIMANO M431, 48/36/26
DERAILLEURS R/F	SHIMANO DEORE/ ALIVIO
SHIFTERS	SHIMANO ALIVIO

MAGNESIUM WHITE, GLOSS (WHT)

HANDLEBAR/STEM	CANNONDALE C3
BRAKES	SHIMANO M395 HYDRAULIC DISC
SIZES	S, M, L, X, J



JET BLACK, GLOSS (BLK)



C130X3
QUICK CX 3

FRAME	QUICK CX, 1.5" HT, OPTIMIZED 6061 ALLOY, SAVE
FORK	RST NEON PLS 1.5" MNL, 50MM W/ LOCKOUT
TIRES	KENDA HAPPY MEDIUM, 700X35C

CRANKS	SHIMANO M171, 48/38/28
DERAILLEURS R/F	SHIMANO ALIVIO / M191
SHIFTERS	SHIMANO ACERA

40 ORANGE, GLOSS (ORG)

HANDLEBAR/STEM	CANNONDALE C4 /C3
BRAKES	TEKTRO NOVELA MECHANICAL DISC
SIZES	S, M, L, X, J



C13QX4

QUICK CX 4

FRAME QUICK CX RIGID, OPTIMIZED 6061 ALLOY, SAVE

FORK FATTY RIGID DISC, ALLOY

TIRES KENDA HAPPY MEDIUM, 700X35C

CRANKS SHIMANO M171 48/38/28

DERAILLEURS R/F SHIMANO ACERA / M191

SHIFTERS SHIMANO ALTUS

STEALTH GREY, MATTE (GRY)

HANDLEBAR/STEM CANNONDALE C4

BRAKES TEKTRONOVELA MECHANICAL DISC

SIZES S, M, L, X, J



C13QX5

QUICK CX 5

FRAME QUICK CX, OPTIMIZED 6061 ALLOY, SAVE

FORK SR SUNTOUR NEX W/ LOCKOUT, 50MM

TIRES KENDA HAPPY MEDIUM, 700X35C

CRANKS SHIMANO M171 48/38/28

DERAILLEURS R/F SHIMANO ALTUS / M191

SHIFTERS SHIMANO ALTUS

JET BLACK, GLOSS (BLK)

HANDLEBAR/STEM CANNONDALE C4

BRAKES CANNONDALE C4 V-BRAKE

SIZES S, M, L, X, J

ADVENTURE

› WHEN ONLY THE BEST WILL DO.

Whether you're taking a spin from your summer house in the Hamptons, going vineyard to vineyard in Napa or simply enjoying a sunny ride through the park with the kids, the **Adventure's** blend of upright comfort, lightweight efficiency and premium elegance make it the perfect choice.



C13AS1

ADVENTURE 1

FRAME	ADVENTURE, DOUBLE BUTTED 6061 ALLOY
FORK	ADVENTURE TRAIL SL SL SUSPENSION, ALLOY, 35MM
TIRES	KENDA KWICK TRAX, 700 X 38C

CRANKS	SHIMANO M311, 48/38/28
DERAILLEURS R/F	SHIMANO ALIVIO / M191
SHIFTERS	SHIMANO REVO TWIST TYPE

HANDLEBAR/STEM	CANNONDALE C4 / TRANS-X TOOL-FREE ADJUSTABLE
BRAKES	CANNONDALE V BRAKE W/ MODULATOR
SIZES	S, M, L, X, J

JET BLACK, MATTE (BLK)

› REASSURINGLY SIMPLE

A low-standover frame design, user-friendly twist-style shifters and a tool-free adjustable stem keep things simple, streamlined and clean for confidence-inspiring cycling.

› LIGHTER IS BETTER

Cannondale's aluminum expertise and thoughtful component spec make the **Adventure** bikes pleasingly light. Easier for climbing hills or hanging in the garage.

› RIDER TAILORED GEOMETRY - ADVENTURE

Stable handling, with our most upright riding position for comfort and a seat angle that balances efficient pedaling with being able to comfortably touch the ground.

See also Women's Adventure



C13AS2

ADVENTURE 2

FRAME	ADVENTURE, DOUBLE BUTTED 6061 ALLOY
FORK	RST SOFI T, 50MM
TIRES	KENDA KOURIER, 700 X 38C

CRANKS	SHIMANO M131, 48/38/28
DERAILLEURS R/F	SHIMANO ALTUS / M191
SHIFTERS	SHIMANO REVO TWIST TYPE

HANDLEBAR/STEM	CANNONDALE C4 / TRANS-X TOOL-FREE ADJUSTABLE
BRAKES	CANNONDALE V BRAKE W/ MODULATOR
SIZES	S, M, L, X, J

MAGNESIUM WHITE, GLOSS (WHT)



C13CS2

ADVENTURE 2 - 26"

FRAME	ADVENTURE 26", DOUBLE BUTTED 6061 ALLOY
FORK	RST SOFI T 26", 50MM
TIRES	KENDA KRANIUM, 26 X 2.1"

CRANKS	SHIMANO M131, 48/38/28
DERAILLEURS R/F	SHIMANO ALTUS / M191
SHIFTERS	SHIMANO REVO TWIST TYPE

HANDLEBAR/STEM	CANNONDALE C4 / TRANS-X TOOL-FREE ADJUSTABLE
BRAKES	CANNONDALE V BRAKE W/ MODULATOR
SIZES	S, M, L, X, J

CHARCOAL GREY MATTE (GRY)



JET BLACK, GLOSS (BLK)

C13AS3

ADVENTURE 3

FRAME	ADVENTURE, DOUBLE BUTTED 6061 ALLOY
FORK	SR SUNTOUR CR8V, 50MM
TIRES	KENDA KOURIER, 700 X 38C

CRANKS	SHIMANO M131, 48/38/28
DERAILLEURS R/F	SHIMANO TX
SHIFTERS	SHIMANO REVO TWIST TYPE

MAGNESIUM WHITE, GLOSS (WHT)

HANDLEBAR/STEM	CANNONDALE C4 / PROMAX MQ417
BRAKES	CANNONDALE V BRAKE W/ MODULATOR
SIZES	S, M, L, X, J



MAGNESIUM WHITE, GLOSS (WHT)

C13CS3

ADVENTURE 3 - 26"

FRAME	ADVENTURE 26", DOUBLE BUTTED 6061 ALLOY
FORK	SR SUNTOUR CR8V 26", 50MM
TIRES	KENDA KRANIUM, 26 X 2.1"

CRANKS	SHIMANO M131, 48/38/28
DERAILLEURS R/F	SHIMANO TX
SHIFTERS	SHIMANO REVO TWIST TYPE

JET BLACK, GLOSS (BLK)

HANDLEBAR/STEM	CANNONDALE C4 / PROMAX MQ417
BRAKES	CANNONDALE V BRAKE W/ MODULATOR
SIZES	S, M, L, X, J

RECREATION/URBAN SPECIFICATIONS

	BAD BOY 1	BAD BOY 5	BAD BOY 9
CODE	C13BB1	C13BB5	C13BB9
FRAME	BAD BOY STEALTH, OPTIMIZED 6061 ALLOY, HEADSHOK	BAD BOY, OPTIMIZED 6061 ALLOY, 1.5 SI HEAD TUBE	BAD BOY, OPTIMIZED 6061 ALLOY, 1-1/8" HEAD TUBE
FORK	HEADSHOK SOLO DL50, 50MM W/ LOCKOUT, OPI	CANNONDALE SOLO RIGID, OPI, 1.5" STEERER	CANNONDALE FATTY RIGID, 1-1/8" STEERER
RIMS	CANNONDALE C2 URBAN SL, 32 HOLE	CANNONDALE C3 URBAN, 32 HOLE	CANNONDALE C3 URBAN, 32 HOLE
HUBS	CANNONDALE LEFTY SL FRONT, SHIMANO M525 DEORE REAR	CANNONDALE LEFTY SL FRONT, FORMULA DC22 REAR	CANNONDALE C4 FRONT AND REAR
SPOKES	STAINLESS XD BLACK, 15G	STAINLESS XD BLACK, 15G	STAINLESS XD BLACK, 15G
TIRES	WTB FREEDOM THICKSLICK, 700X28C	WTB FREEDOM THICKSLICK, 700X28C	WTB FREEDOM THICKSLICK, 700X28C
PEDALS	CANNONDALE URBAN 6POINT3 ALLOY	CANNONDALE URBAN 6POINT3 COMPOSITE	CANNONDALE REINFORCED COMPOSITE
CRANK	OMET 42/32/24	SHIMANO M431, BAD BOY, 48/36/26	SHIMANO M171, 48/38/28
BOTTOM BRACKET	TANGE CARTRIDGE	TANGE CARTRIDGE	TANGE CARTRIDGE
CHAIN	KMC X10 BLACK, 10-SPEED	KMC Z99 BLACK, 9-SPEED	KMC Z51 BLACK, 8-SPEED
REAR COGS	SHIMANO HG81, 11-34, 10-SPEED	SUNRACE CSM969, BAD BOY, 11-32, 9-SPEED	SUNRACE CSM668 11-32, BAD BOY, 8-SPEED
FR. DERAILLEUR	SHIMANO DEORE, 34.9MM CLAMP	SHIMANO ALIVIO, 34.9MM CLAMP	SHIMANO ALTUS, 34.9MM CLAMP
REAR DERAILLEUR	SHIMANO SLX, SHADOW	SHIMANO DEORE, SHADOW	SHIMANO ALIVIO
SHIFTERS	SHIMANO DEORE	SHIMANO ALIVIO	SHIMANO M310 RAPIDFIRE PLUS
HANDLEBAR	CANNONDALE SI URBAN OPI STEM/ HANDLEBAR W/ SI LIGHT, 7 DEG.	CANNONDALE SI URBAN OPI STEM/ HANDLEBAR W/ SI LIGHT, 7 DEG.	CANNONDALE C4 ALLOY, FLAT, 620MM
GRIPS	CANNONDALE URBAN, LOCK-ON	CANNONDALE URBAN, LOCK-ON	CANNONDALE URBAN, LOCK-ON
STEM	CANNONDALE SI URBAN OPI STEM/ HANDLEBAR W/ LIGHT, 7 DEG.	CANNONDALE SI URBAN OPI STEM/ HANDLEBAR W/ LIGHT, 7 DEG.	CANNONDALE C4, 31.8, 6 DEG
HEADSET	CANNONDALE HEADSHOK SI	TANGE CUSTOM 1.5"	TANGE SI 1-1/8"
BRAKES	MAGURA MT2 HYDRAULIC DISC	SHIMANO M395 HYDRAULIC DISC	TEKTRO NOVELA MECHANICAL DISC
BRAKE LEVERS	MAGURA MT2 HYDRAULIC DISC	SHIMANO M395 HYDRAULIC DISC	CANNONDALE C4
SADDLE	CANNONDALE BAD BOY URBAN	CANNONDALE BAD BOY URBAN	CANNONDALE BAD BOY URBAN
SEATPOST	CANNONDALE C2, 2 BOLT, ALLOY, 31.6 X 350MM	CANNONDALE C4, ALLOY, 31.6 X 350MM	CANNONDALE C4, ALLOY, 31.6 X 350MM
SIZES	S, M, L, X	S, M, L, X	S, M, L, X
COLOR 1 (CODE)	BLACK ANODIZED W/ REFLECTIVE DECALS, MATTE (BBQ)	JET BLACK W/ REFLECTIVE DECALS, MATTE (BBQ)	JET BLACK W/ REFLECTIVE DECALS, MATTE (BBQ)

	HOOLIGAN 1	QUICK CARBON 1	QUICK CARBON 2	QUICK SL 1	QUICK SL 2
CODE	C13HL1	C13QR1	C13QR2	C13QR1	C13QR2
FRAME	HOOLIGAN DELTA V, URBAN COMPACT, 20" WHEEL, 1.5 SI HEAD TUBE	QUICK FULL CARBON, W/ SAVE FEATURES	QUICK FULL CARBON, W/ SAVE FEATURES	QUICK SL BB30, OPTIMIZED 6061 ALLOY, SAVE	QUICK SL BB30, OPTIMIZED 6061 ALLOY, SAVE
FORK	CANNONDALE SOLO RIGID, OPI, 1.5" STEERER	QUICK SI, FULL CARBON, 1-1/8"	QUICK SI, FULL CARBON, 1-1/8"	QUICK SI, CARBON BLADES, 1-1/8" STEERER	QUICK SI, CARBON BLADES, 1-1/8" STEERER
RIMS	CANNONDALE DC3.0, 20", 32 HOLE	MAVIC KSYRIUM ELITE	ELEMENT C3	ELEMENT C2	ELEMENT C3
HUBS	CANNONDALE LEFTY SL FRONT, SHIMANO NEXUS 3-SPEED, CENTERLOCK DISC REAR	MAVIC KSYRIUM ELITE	ELEMENT C3	ELEMENT C2	ELEMENT C3
SPOKES	STAINLESS XD BLACK, 15G	MAVIC KSYRIUM ELITE	ELEMENT XERO STAINLESS	ELEMENT XERO BLADED STAINLESS	ELEMENT XERO STAINLESS
TIRES	KENDA QUEST, 20 X 1.5"	SCHWALBE MARATHON SUPREME, 700X28C	KENDA KWICK, 700X28C	KENDA KWICK ROLLER SPORT 700X32C	KENDA HAPPY MEDIUM, 700X35C
PEDALS	CANNONDALE URBAN 6POINT3 ALLOY	QUICK ALLOY W/ KRATON INSERTS	QUICK ALLOY W/ KRATON INSERTS	QUICK ALLOY W/ KRATON INSERTS	QUICK ALLOY W/ KRATON INSERTS
CRANK	FSA VERO, SINGLE RING, DUAL ALLOY CHAINGUARD, 48T	FSA SLK CARBON, BB30, 50/34	FSA OMEGA, BB30, 50/34	FSA GOSSAMER COMPACT BB30 50/34	FSA OMEGA, BB30, 50/34
BOTTOM BRACKET	CANNONDALE TP148 ECCENTRIC, TANGE CARTRIDGE, JIS	FSA BB30	FSA BB30	FSA BB30	FSA BB30
CHAIN	KMC Z72	SHIMANO ULTEGRA 6700, 10-SPEED	KMC X10SL, 10-SPEED	KMC X10, 10-SPEED	KMC Z99, 9-SPEED
REAR COGS	SHIMANO 16T	SHIMANO 5700, 11-28, 10-SPEED	SRAM APEX 11-32, 10-SPEED	SHIMANO TIAGRA 4600 12-28, 10-SPEED	SHIMANO HG50, 11-30, 9-SPEED
FR. DERAILLEUR	N/A	SHIMANO 6700, BRAZE ON	SRAM APEX, BRAZE ON	SHIMANO TIAGRA, 31.8 CLAMP	SHIMANO R443, 31.8 CLAMP
REAR DERAILLEUR	N/A	SHIMANO 6700	SRAM APEX	SHIMANO 105 5700	SHIMANO SORA
SHIFTERS	SHIMANO NEXUS REVO 3-SPEED	SHIMANO TIAGRA, FLAT BAR	SRAM X5, FLAT BAR	SHIMANO TIAGRA 4600 FLATBAR ROAD, RAPIDFIRE PLUS	SHIMANO SORA, FLATBAR ROAD, RAPIDFIRE PLUS
HANDLEBAR	CANNONDALE URBAN 6061, 620MM	CANNONDALE C2, POLISHED BLACK, 580MM	CANNONDALE C3, 580MM	CANNONDALE C3, BUTTED 6061 ALLOY, 25MM RISE, 640MM	CANNONDALE C3, BUTTED 6061 ALLOY, 25MM RISE, 640MM
GRIPS	CANNONDALE URBAN, LOCK-ON	CANNONDALE ERGO PERFORMANCE, LOCK ON	CANNONDALE ERGO PERFORMANCE, LOCK ON	CANNONDALE ERGO PERFORMANCE, LOCK ON	CANNONDALE ERGO PERFORMANCE, LOCK ON
STEM	CANNONDALE C3 ADJUSTABLE, 1.5", 3-D FORGED	CANNONDALE C2, POLISHED BLACK	CANNONDALE C3	CANNONDALE C3, 31.8, 12 DEG.	CANNONDALE C3, 31.8, 12 DEG.
HEADSET	TANGE CUSTOM 1.5"	TANGE SI	TANGE SI	TANGE SI	TANGE SI
BRAKES	SHIMANO M375 MECHANICAL DISC, 160/160MM	TEKTRO CX9 MINI V, CNC	CANNONDALE, MINI V	CANNONDALE C2 MINI V, CARTRIDGE PADS	CANNONDALE C2 MINI V, CARTRIDGE PADS
BRAKE LEVERS	CANNONDALE C3	TEKTRO ML940	CANNONDALE CBL 9.1	TEKTRO MT5.0 CARBON	CANNONDALE W/ KRATON
SADDLE	CANNONDALE HOOLIGAN URBAN	FIZIK, ALIANTE	CANNONDALE, QUICK ERGO PERFORMANCE	CANNONDALE QUICK ERGO PERFORMANCE	CANNONDALE QUICK ERGO PERFORMANCE
SEATPOST	CANNONDALE C3, 2 BOLT, ALLOY, 31.6 X 520MM	QUICK FULL CARBON	QUICK FULL CARBON	CANNONDALE C2, 2014 ALLOY, 2 BOLT, 27.2X350MM	CANNONDALE C3, 6061 ALLOY, 2 BOLT, 27.2X350MM
SIZES	ONE SIZE	S, M, L, X, J	S, M, L, X, J	S, M, L, X, J	S, M, L, X, J
COLOR 1 (CODE)	JET BLACK, MATTE (BBQ)	RAW MATTE CARBON (CRB)	RAW MATTE CARBON (CRB)	BRUSHED ALUMINUM, GLOSS (RAW)	JET BLACK, MATTE (BBQ)
EXTRAS	INTEGRATED SLIDE2GO ACCESSORY MOUNT	N/A	N/A	N/A	N/A

Specifications subject to change without notice.

RECREATION/URBAN SPECIFICATIONS

	QUICK SL 3	QUICK 4	QUICK 5	QUICK 6	QUICK CX 1
CODE	C13QR3	C13QR4	C13QR5	C13QR6	C13QX1
FRAME	QUICK SL, OPTIMIZED 6061 ALLOY, SAVE	QUICK, BUTTED 6061 ALLOY, SAVE	QUICK, BUTTED 6061 ALLOY, SAVE	QUICK, BUTTED 6061 ALLOY, SAVE	QUICK CX HEADSHOK, OPTIMIZED 6061 ALLOY, SAVE
FORK	QUICK SI, CARBON BLADES, 1-1/8" STEERER	QUICK, CARBON BLADES, 1-1/8" STEERER	CANNONDALE QUICK, 6061 ALLOY, 1-1/8" STEERER	CANNONDALE QUICK, CROMOLY, 1-1/8" STEERER	HEADSHOK FATTY DL50, 50MM W/ LOCKOUT, OPI
RIMS	ELEMENT C3	ELEMENT C3 - 700C (26" ON XS)	CANNONDALE C4, DOUBLE WALL, 32 HOLE	CANNONDALE C4, DOUBLE WALL, 32 HOLE	MADDUX DC3.0, DOUBLE WALL W/ EYELET, 32 HOLE
HUBS	ELEMENT C3	ELEMENT C3	CANNONDALE C4	CANNONDALE C4	SHIMANO DEORE M475 DISC
SPOKES	ELEMENT XERO STAINLESS	ELEMENT XERO STAINLESS	STAINLESS, 15G	STAINLESS, 15G	STAINLESS STEEL, XD BLACK, 15G
TIRES	KENDA KWICK BITUMEN 700X32C	KENDA KWICK TRAX, 700X32C (26X1.5" ON XS)	KENDA KWICK TRAX, 700X32C	KENDA KOURIER, 700X32C	KENDA HAPPY MEDIUM, 700X35C
PEDALS	QUICK ALLOY W/ KRATON INSERTS	QUICK REINFORCED COMPOSITE W/ KRATON INSERTS	QUICK REINFORCED COMPOSITE W/ KRATON INSERTS	CANNONDALE REINFORCED COMPOSITE	QUICK CX REINFORCED COMPOSITE
CRANK	FSA ALPHA DRIVE, 48/36/26	SHIMANO M171, 48/38/28	SHIMANO M131, 48/38/28	SHIMANO M131, 48/38/28	SHIMANO M521, 48/36/26
BOTTOM BRACKET	TANGE CARTRIDGE	TANGE CARTRIDGE	TANGE CARTRIDGE	TANGE CARTRIDGE	SHIMANO BB-ES25, OCTALINK
CHAIN	KMC Z99, 9-SPEED	KMC 8-SPEED	KMC 8-SPEED	KMC 8-SPEED	KMC Z99, 9-SPEED
REAR COGS	SHIMANO HG50, 12-27, 9-SPEED	SUNRACE CSM668, 11-32, 8-SPEED	SUNRACE CSM668, 11-32, 8-SPEED	SHIMANO HG20, 12-28, 7-SPEED	SHIMANO HG30, 12-30, 9-SPEED
FR. DERAILLEUR	SHIMANO ALIVIO, 31.8 CLAMP	SHIMANO M191, 31.8 CLAMP	SHIMANO M191, 31.8 CLAMP	SHIMANO M191, 31.8 CLAMP	SHIMANO ALIVIO, 31.8 CLAMP
REAR DERAILLEUR	SHIMANO DEORE	SHIMANO ALIVIO	SHIMANO ALTUS	SHIMANO ALTUS	SHIMANO SLX
SHIFTERS	SHIMANO ALIVIO RAPIDFIRE PLUS	SHIMANO M310 RAPIDFIRE PLUS	SHIMANO M310 RAPIDFIRE PLUS	SHIMANO EASYFIRE	SHIMANO DEORE
HANDLEBAR	CANNONDALE C4, 6061 ALLOY, 25MM RISE, 640MM	CANNONDALE C4, 6061 ALLOY, 25MM RISE, 640MM	CANNONDALE C4, 6061 ALLOY, 25MM RISE, 640MM	CANNONDALE C4, 6061 ALLOY, 25MM RISE, 640MM	CANNONDALE C3, 6061 DOUBLE BUTTED, 20MM RISE, 640MM
GRIPS	CANNONDALE ERGO PERFORMANCE, LOCK ON	CANNONDALE ERGO PERFORMANCE, LOCK ON	CANNONDALE ERGO PERFORMANCE	CANNONDALE ERGO PERFORMANCE	CANNONDALE ERGO PERFORMANCE, LOCK ON
STEM	CANNONDALE C4, 31.8, 12 DEG.	CANNONDALE C4, 31.8, 12 DEG.	CANNONDALE C4, 31.8, 12 DEG.	CANNONDALE C4, 31.8, 12 DEG.	CANNONDALE C3 HEADSHOK, 3-D FORGED, 31.8, 12 DEG RISE
HEADSET	TANGE SI	TANGE SI	TANGE SI	TANGE SI	TANGE SI HEADSHOK
BRAKES	CANNONDALE C3 MINI V, CARTRIDGE PADS	CANNONDALE C4 MINI V	CANNONDALE C4 MINI V	CANNONDALE C4 MINI V	MAGURA MT2 HYDRAULIC DISC
BRAKE LEVERS	CANNONDALE W/ KRATON	CANNONDALE C3 W/ KRATON	CANNONDALE C3 W/ KRATON	SHIMANO	MAGURA MT2 HYDRAULIC DISC
SADDLE	CANNONDALE QUICK ERGO PERFORMANCE	CANNONDALE QUICK ERGO PERFORMANCE	CANNONDALE QUICK ERGO PERFORMANCE	CANNONDALE QUICK ERGO PERFORMANCE	CANNONDALE QUICK CX ERGO
SEATPOST	CANNONDALE C4, 6061 ALLOY, 27.2X350MM	CANNONDALE C4, 6061 ALLOY, 27.2X350MM	CANNONDALE C4, 6061 ALLOY, 27.2X350MM	CANNONDALE C4, 6061 ALLOY, 27.2X350MM	CANNONDALE C3, 2 BOLT, 2014 ALLOY, 31.6 X 350MM
SIZES	S, M, L, X, J	XS, S, M, L, X, J	S, M, L, X, J	S, M, L, X, J	S, M, L, X, J
COLOR 1 (CODE)	40 BLUE, GLOSS (BLU)	JET BLACK, GLOSS (BLK)	BERSERKER GREEN, GLOSS (GRN)	JET BLACK, MATTE (BBQ)	BRUSHED ALUMINUM, GLOSS (RAW)
COLOR 2 (CODE)	MAGNESIUM WHITE, GLOSS (WHT)	FINE SILVER, GLOSS (SLV)	MAGNESIUM WHITE, GLOSS (WHT)	N/A	N/A

	QUICK CX 2	QUICK CX 3	QUICK CX 4	QUICK CX 5	ADVENTURE 1
CODE	C13QX2	C13QX3	C13QX4	C13QX5	C13AS1
FRAME	QUICK CX, OPTIMIZED 6061 ALLOY, SAVE, 1.5" HEAD TUBE	QUICK CX, OPTIMIZED 6061 ALLOY, SAVE, 1.5" HEAD TUBE	QUICK CX RIGID, OPTIMIZED 6061 ALLOY, SAVE, 1-1/8" HEAD TUBE	QUICK CX RIGID, OPTIMIZED 6061 ALLOY, SAVE, 1-1/8" HEAD TUBE	ADVENTURE, DOUBLE BUTTED 6061 ALLOY
FORK	RST NEON PLS 1.5", TNL LOCKOUT, 50MM	RST NEON PLS 1.5", MNL LOCKOUT 50MM	FATTY RIGID DISC, ALLOY, 1-1/8" STEERER	SR SINTOUR NEX W/ LOCKOUT, 50MM, 1-1/8" STEERER	ADVENTURE TRAIL SI SL SUSPENSION, 35MM, 1-1/8" STEERER
RIMS	MADDUX DC3.0, DOUBLE WALL W/ EYELET, 32 HOLE	MADDUX DC3.0, DOUBLE WALL W/ EYELET, 32 HOLE	MADDUX DC3.0, DOUBLE WALL W/ EYELET, 32 HOLE	MADDUX TC5.0, DOUBLE WALL W/ EYELET, 32 HOLE	CANNONDALE C3, DOUBLE WALL, 32 HOLE
HUBS	SHIMANO M475 ALIVIO CENTERLOCK DISC	CANNONDALE C4	CANNONDALE C4	CANNONDALE C4	CANNONDALE C4
SPOKES	STAINLESS STEEL XD BLACK, 15G	STAINLESS STEEL, XD BLACK, 15G	STAINLESS STEEL XD BLACK, 15G	STAINLESS STEEL XD BLACK, 15G	STAINLESS, 14G
TIRES	KENDA KWICK ROLLER SPORT 700X32C	KENDA HAPPY MEDIUM, 700X35C	KENDA HAPPY MEDIUM, 700X35C	KENDA HAPPY MEDIUM, 700X35C	KENDA KWICK TRAX, 700 X 38C
PEDALS	QUICK CX REINFORCED COMPOSITE	QUICK CX REINFORCED COMPOSITE	QUICK CX REINFORCED COMPOSITE	QUICK CX REINFORCED COMPOSITE	FPD PLATFORM W/ KRATON INSERTS
CRANK	SHIMANO M431, 48/36/26	SHIMANO M171, 48/38/28	SHIMANO M171 48/38/28	SHIMANO M171 48/38/28	SHIMANO M311, 48/38/28
BOTTOM BRACKET	TANGE CARTRIDGE	TANGE CARTRIDGE	TANGE CARTRIDGE	TANGE CARTRIDGE	TANGE CARTRIDGE
CHAIN	KMC Z99, 9-SPEED	KMC Z82, 8-SPEED	KMC Z51, 8-SPEED	KMC Z51, 8-SPEED	KMC 8-SPEED
REAR COGS	SHIMANO HG30, 11-32, 9-SPEED	SUNRACE CSG66 11-32, 8-SPEED	SUNRACE CSG66 11-32, 8-SPEED	SUNRACE CSG66 11-32, 8-SPEED	SUNRACE CSM66, 11-32, 8-SPEED
FR. DERAILLEUR	SHIMANO ALIVIO, 31.8 CLAMP	SHIMANO M191, 31.8 CLAMP	SHIMANO M191, 31.8 CLAMP	SHIMANO M191, 31.8 CLAMP	SHIMANO M-191
REAR DERAILLEUR	SHIMANO DEORE	SHIMANO ALIVIO	SHIMANO ACERA	SHIMANO ALTUS	SHIMANO ALIVIO
SHIFTERS	SHIMANO ALIVIO	SHIMANO ACERA	SHIMANO ALTUS	SHIMANO ALTUS	SHIMANO REVO TWIST TYPE
HANDLEBAR	CANNONDALE C3, 6061 DOUBLE BUTTED, 20MM RISE, 60MM	CANNONDALE C4, 6061, 25MM RISE, 640MM	CANNONDALE C4, 6061, 25MM RISE, 640MM	CANNONDALE C4, 6061, 25MM RISE, 640MM	CANNONDALE C4, ALLOY, 620 X 50MM RISE
GRIPS	CANNONDALE ERGO PERFORMANCE, LOCK ON	CANNONDALE ERGO PERFORMANCE, LOCK ON	CANNONDALE ERGO PERFORMANCE	CANNONDALE ERGO PERFORMANCE	CANNONDALE ERGO COMFORT, LOCK-ON
STEM	CANNONDALE C3, 1.5", 3-D FORGED, 31.8, 12 DEG	CANNONDALE C3, 1.5", 3-D FORGED, 31.8, 12 DEG	CANNONDALE C4, 1-1/8", 31.8, 12 DEG	CANNONDALE C4, 1-1/8", 31.8, 12 DEG	TRANZ X COMFORT GRIP, TOOL-FREE ADJUSTMENT
HEADSET	TANGE CUSTOM 1.5"	TANGE CUSTOM 1.5"	TANGE 1-1/8"	TANGE 1-1/8"	TANGE SEMI INTEGRATED
BRAKES	SHIMANO M395 HYDRAULIC DISC	TEKTRO NOVELA MECHANICAL DISC	TEKTRO NOVELA MECHANICAL DISC	TEKTRO NOVELA MECHANICAL DISC	CANNONDALE V BRAKE W/ MODULATOR
BRAKE LEVERS	SHIMANO M395 HYDRAULIC DISC	SHIMANO BRM375	CANNONDALE C4	CANNONDALE C4	CANNONDALE, 4 FINGER W/ KRATON COMFORT INSERT
SADDLE	CANNONDALE QUICK CX ERGO	CANNONDALE QUICK CX ERGO	CANNONDALE QUICK CX ERGO	CANNONDALE QUICK CX ERGO	CANNONDALE ULTRA COMFORT
SEATPOST	CANNONDALE C3, 2 BOLT, 2014 ALLOY, 31.6 X 350MM	CANNONDALE C4, ALLOY, 31.6 X 350MM	CANNONDALE C4, ALLOY, 31.6 X 350MM	CANNONDALE C4, ALLOY, 31.6 X 350MM	CANNONDALE SUSPENSION, 40MM TRAVEL, 27.2 X 350MM
SIZES	S, M, L, X, J	S, M, L, X, J	S, M, L, X, J	S, M, L, X, J	S, M, L, X, J
COLOR 1 (CODE)	MAGNESIUM WHITE, GLOSS (WHT)	40 ORANGE (ORG)	STEALTH GREY, MATTE (GRY)	JET BLACK, GLOSS (BLK)	JET BLACK, MATTE (BLK)
COLOR 2 (CODE)	N/A	JET BLACK, GLOSS (BLK)	N/A	N/A	N/A

Specifications subject to change without notice.

RECREATION/URBAN SPECIFICATIONS

	ADVENTURE 2	ADVENTURE 2 - 26"	ADVENTURE 3	ADVENTURE 3 - 26"
CODE	C13AS2	C13CS2	C13AS3	C13CS3
FRAME	ADVENTURE, DOUBLE BUTTED 6061 ALLOY	ADVENTURE 26", DOUBLE BUTTED 6061 ALLOY	ADVENTURE, DOUBLE BUTTED 6061 ALLOY	ADVENTURE 26", DOUBLE BUTTED 6061 ALLOY
FORK	RST SOFI T, 50MM, 1-1/8" STEERER	RST SOFI T 26", 50MM, 1-1/8" STEERER	SR SUNTOUR CR8V, 50MM, 1-1/8" STEERER	SR SUNTOUR CR8V 26", 50MM, 1-1/8" STEERER
RIMS	CANNONDALE C4, DOUBLE WALL, 32 HOLE	CANNONDALE C4, DOUBLE WALL, 26", 32 HOLE	CANNONDALE C4, DOUBLE WALL, 32 HOLE	CANNONDALE C4, DOUBLE WALL, 26", 32 HOLE
HUBS	CANNONDALE C4	CANNONDALE C4	CANNONDALE C4	CANNONDALE C4
SPOKES	STAINLESS, 14G	STAINLESS, 14G	STAINLESS, 14G	STAINLESS, 14G
TIRES	KENDA KOURIER, 700 X 38C	KENDA KRANIUM, 26 X 2.1"	KENDA KOURIER, 700 X 38C	KENDA KRANIUM, 26 X 2.1"
PEDALS	FPD PLATFORM W/ KRATON INSERTS	FPD PLATFORM W/ KRATON INSERTS	FPD PLATFORM W/ KRATON INSERTS	FPD PLATFORM W/ KRATON INSERTS
CRANK	SHIMANO M131, 48/38/28	SHIMANO M131, 48/38/28	SHIMANO M131, 48/38/28	SHIMANO M131, 48/38/28
BOTTOM BRACKET	TANGE CARTRIDGE	TANGE CARTRIDGE	TANGE CARTRIDGE	TANGE CARTRIDGE
CHAIN	KMC 8-SPEED	KMC 8-SPEED	KMC 7-SPEED	KMC 7-SPEED
REAR COGS	SUNRACE CSM66, 11-32, 8-SPEED	SUNRACE CSM66, 11-32, 8-SPEED	SHIMANO, 14-34, 7-SPEED	SHIMANO, 14-34, 7-SPEED
FR. DERAILLEUR	SHIMANO M-191	SHIMANO M-191	SHIMANO TX	SHIMANO TX
REAR DERAILLEUR	SHIMANO ALTUS	SHIMANO ALTUS	SHIMANO TX	SHIMANO TX
SHIFTERS	SHIMANO REVO TWIST TYPE	SHIMANO REVO TWIST TYPE	SHIMANO REVO TWIST TYPE	SHIMANO REVO TWIST TYPE
HANDLEBAR	CANNONDALE C4, 50MM RISE, ALLOY, 620MM	CANNONDALE C4, 50MM RISE, ALLOY, 620MM	CANNONDALE C4, 50MM RISE, ALLOY, 620MM	CANNONDALE C4, 50MM RISE, ALLOY, 620MM
GRIPS	CANNONDALE ERGO COMFORT, LOCK-ON	CANNONDALE ERGO COMFORT, LOCK-ON	CANNONDALE ERGO COMFORT	CANNONDALE ERGO COMFORT,
STEM	TRANZ X COMFORT GRIP, TOOL-FREE ADJUSTMENT, QUILL TYPE	TRANZ X COMFORT GRIP, TOOL-FREE ADJUSTMENT, QUILL TYPE	PROMAX MQ417 ALLOY, 80MM	PROMAX MQ417 ALLOY, 80MM
HEADSET	TANGE SEMI INTEGRATED	TANGE SEMI INTEGRATED	TANGE SEMI INTEGRATED	TANGE SEMI INTEGRATED
BRAKES	CANNONDALE V BRAKE W/ MODULATOR	CANNONDALE V BRAKE W/ MODULATOR	CANNONDALE V BRAKE W/ MODULATOR	CANNONDALE V BRAKE W/ MODULATOR
BRAKE LEVERS	CANNONDALE, 4 FINGER W/ KRATON COMFORT INSERT	CANNONDALE, 4 FINGER W/ KRATON COMFORT INSERT	CANNONDALE, 4 FINGER W/ KRATON COMFORT INSERT	CANNONDALE, 4 FINGER W/ KRATON COMFORT INSERT
SADDLE	CANNONDALE ULTRA COMFORT	CANNONDALE ULTRA COMFORT	CANNONDALE ULTRA COMFORT	CANNONDALE ULTRA COMFORT
SEATPOST	CANNONDALE SUSPENSION, 40MM TRAVEL, 27.2 X 350MM	CANNONDALE SUSPENSION, 40MM TRAVEL, 27.2 X 350MM	CANNONDALE SUSPENSION, 40MM TRAVEL, 27.2 X 350MM	CANNONDALE SUSPENSION, 40MM TRAVEL, 27.2 X 350MM
SIZES	S, M, L, X, J	S, M, L, X, J	S, M, L, X, J	S, M, L, X, J
COLOR 1 (CODE)	MAGNESIUM WHITE, GLOSS (WHT)	CHARCOAL GREY MATTE (GRY)	MAGNESIUM WHITE, GLOSS (WHT)	JET BLACK, GLOSS (BLK)
COLOR 2 (CODE)	CHARCOAL GREY MATTE (GRY)	MAGNESIUM WHITE, GLOSS (WHT)	JET BLACK, GLOSS (BLK)	MAGNESIUM WHITE, GLOSS (WHT)

RECREATION/URBAN GEOMETRY

BADBOY HEADSHOK

SPECIFICATIONS	SMALL	MEDIUM	LARGE	X-LARGE
A SEAT TUBE LENGTH (CM/IN)	39/15.4	46/18.1	51/20.1	56/22.0
B TOP TUBE HORIZONTAL (CM)	55	57.5	60	62
C TOP TUBE ACTUAL (CM/IN)	52.1/20.5	54.7/21.5	57.3/22.6	59.7/23.5
D HEAD TUBE ANGLE (DEGREES)	70°	71°	★	★
E SEAT TUBE ANGLE (DEGREES)	74.5°	73.5°	73°	72.5°
F STANDOVER HEIGHT (CM)	77	80.4	82.6	84.7
G HEAD TUBE LENGTH (CM)	11.4	★	★	★
H WHEELBASE (CM)	104.4	105.8	108.1	109.8
I FRONT CENTER (CM)	61.4	62.8	65.1	66.8
J CHAIN STAY LENGTH (CM)	43.5	★	★	★
K BOTTOM BRACKET DROP (CM)	5.1	★	★	★
L BOTTOM BRACKET HEIGHT (CM)	29.5	★	★	★
M FORK RAKE (CM)	4.5	★	★	★
N TRAIL (CM)	7.8	7.2	★	★

BAD BOY

SPECIFICATIONS	SMALL	MEDIUM	LARGE	X-LARGE
A SEAT TUBE LENGTH (CM/IN)	39/15.4	46/18.1	51/20.1	56/22.0
B TOP TUBE HORIZONTAL (CM)	55	57.5	60	62
C TOP TUBE ACTUAL (CM/IN)	52.1/20.5	54.7/21.5	57.3/22.6	59.7/23.5
D HEAD TUBE ANGLE (DEGREES)	70°	71°	★	★
E SEAT TUBE ANGLE (DEGREES)	74.5°	73.5°	73°	72.5°
F STANDOVER HEIGHT (CM)	73.9	78.2	81.4	84.5
G HEAD TUBE LENGTH (CM)	13	15	17	19
H WHEELBASE (CM)	104.4	105.8	108.1	109.8
I FRONT CENTER (CM)	61.4	62.8	65.1	66.8
J CHAIN STAY LENGTH (CM)	43.5	★	★	★
K BOTTOM BRACKET DROP (CM)	5.1	★	★	★
L BOTTOM BRACKET HEIGHT (CM)	73.9	78.2	81.4	84.5
M FORK RAKE (CM)	4.5	★	★	★
N TRAIL (CM)	7.8	7.2	★	★

HOOLOGAN

SPECIFICATIONS	ONE SIZE
A SEAT TUBE LENGTH (CM/IN)	35/14.6
B TOP TUBE HORIZONTAL (CM)	58.0
C TOP TUBE ACTUAL (CM/IN)	54.7/21.5
D HEAD TUBE ANGLE (DEGREES)	70°
E SEAT TUBE ANGLE (DEGREES)	73°
F STANDOVER HEIGHT (CM)	60
G HEAD TUBE LENGTH (CM)	17.1
H WHEELBASE (CM)	106
I FRONT CENTER (CM)	66.2
J CHAIN STAY LENGTH (CM)	40
K BOTTOM BRACKET DROP (CM)	3.6
L BOTTOM BRACKET HEIGHT (CM)	30.5
M FORK RAKE (CM)	4.5
N TRAIL (CM)	2.6

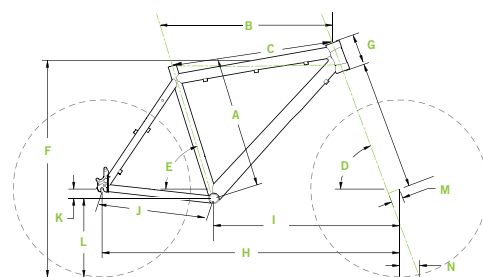

QUICK CARBON

SPECIFICATIONS	SMALL	MEDIUM	LARGE	X-LARGE	JUMBO
A MEASURED SIZE (CM/IN)*	38.5/15.2	41/16.1	46/18.1	51/20.1	57/22.4
B SEAT TUBE ANGLE (DEGREES)	75°	76°	74.5°	73°	72.5°
C HEAD TUBE ANGLE (DEGREES)	71°	71°	71.5°	72°	72.5°
D HORIZONTAL TOP TUBE LENGTH (CM)	53.5	53.5	56	58.5	62
E CHAIN STAY LENGTH (CM)	43	★	★	★	★
F FORK RAKE (CM)	5.0	★	★	★	★
G BOTTOM BRACKET HEIGHT (CM)	27.4	★	★	★	★
H WHEELBASE (CM)	101.4	102.3	103.9	104.8	107.5
I TRAIL (CM)	6.6	6.5	6.2	5.9	5.6
J STANDOVER HEIGHT (CM)	73.8	75.0	78.7	82.8	87.0
K BOTTOM BRACKET DROP (CM)	7.0	★	★	★	★
L FRONT CENTER (CM)	59.5	60.4	61.9	62.8	65.4
M HEAD TUBE LENGTH (CM)	14	13	16	19	22

QUICK SL

SPECIFICATIONS	X-SMALL	SMALL	MED	LARGE	X-LARGE	JUMBO
A SEAT TUBE LENGTH (CM/IN)	32/12.6	38.5/15.2	41.0/16.1	46.0/18.1	51.0/20.1	57.0/22.4
B TOP TUBE HORIZONTAL (CM/IN)	50.5/19.9	53.5/21.1	55.0/21.7	56.5/22.2	59.5/23.4	62.0/24.4
C TOP TUBE ACTUAL (CM/IN)	49.6/19.5	49.2/19.4	50.4/19.8	51.5/20.3	54.0/21.3	56.5/22.2
D HEAD TUBE ANGLE (DEGREES)	70.5°	70.5°	70.5°	71°	71.5°	72°
E SEAT TUBE ANGLE (DEGREES)	75°	75°	75°	74.5°	73°	72.5°
F STANDOVER (CM)	65.6	71	72.7	76.9	81.3	86.2
G HEAD TUBE LENGTH (CM)	14	14	15	17	20	23
H WHEELBASE (CM/IN)	103	104.2	105.7	106.3	107.2	108.5
I FRONT CENTER (CM)	60	61.6	63.2	63.8	64.6	66
J CHAIN STAY LENGTH (CM)	43.5	★	★	★	★	★
K BOTTOM BRACKET DROP (CM)	5.1	7	★	★	★	★
L BOTTOM BRACKET HEIGHT (CM)	27.4	27.4	★	★	★	★
M FORK RAKE (CM)	5	5	★	★	★	★
N TRAIL (CM)	6.3	6.9	6.9	6.6	6.2	5.9

QUICK CX

SPECIFICATIONS	SMALL	MEDIUM	LARGE	X-LARGE	JUMBO
A SEAT TUBE LENGTH OVERALL (CM/IN)	44/17.3	48/18.9	52/20.5	56/22.0	60/23.6
B TOP TUBE HORIZONTAL (CM/IN)	55/21.7	57/22.4	58.5/23.0	60/23.6	62/24.4
C TOP TUBE ACTUAL (CM/IN)	53.3/20.1	54.7/21.5	56.1/22.1	57.6/22.6	59.9/23.6
D HEAD TUBE ANGLE (DEGREES)	69°	69°	70°	70.5°	71.5°
E SEAT TUBE ANGLE (DEGREES)	74°	73.5°	73°	73°	72.5°
F STANDOVER - HEADSHOK (CM/IN)	79.6/31.3	80.9/31.8	82.5/32.5	85.7/33.7	87.3/34.4
F STANDOVER - SUSPENSION (CM/IN)	80.6/31.7	82.5/32.5	84.6/33.3	86.7/34.1	88.9/35.0
F STANDOVER - RIGID (CM/IN)	77.3/30.4	79.1/31.1	81.3/32.0	83.4/32.8	85.6/33.7
G HEAD TUBE LENGTH - HEADSHOK (CM/IN)	11.4/4.5	★	★	★	★
G HEAD TUBE LENGTH - SUSPENSION (CM/IN)	14/5.5	15/5.9	16/6.3	17/6.7	18/7.1
G HEAD TUBE LENGTH - RIGID (CM/IN)	16/6.3	17/6.7	18/7.1	19/7.5	20/7.9
H WHEELBASE (CM/IN)	107.2/42.2	108.8/42.8	108.8/42.8	109.8/43.2	110.2/43.4
I FRONT CENTER	62.2/24.5	63.8/25.1	63.8/25.1	64.8/25.5	65.2/25.7
J CHAIN STAY LENGTH (CM)	45/17.7	★	★	★	★
K BOTTOM BRACKET DROP (CM)	6.7	★	★	★	★
L BOTTOM BRACKET HEIGHT (CM)	33.2	★	★	★	★
M FORK RAKE (CM)	4.5	★	★	★	★
N TRAIL (CM)	8.7	8.7	8.1	7.7	7.1

QUICK

SPECIFICATIONS	X-SMALL	SMALL	MEDIUM	LARGE	X-LARGE	JUMBO
A SEAT TUBE LENGTH (CM/IN)	32.0/12.6	38.5/15.2	41.0/16.1	46.0/18.1	51.0/20.1	57.0/22.4
B TOP TUBE HORIZONTAL (CM/IN)	50.5/19.9	53.5/21.1	54.5/21.5	56/22	58.5/23	62/24.4
C TOP TUBE ACTUAL (CM/IN)	48.4/19.1	50.6/19.9	51.4/20.2	53/20.9	55.6/21.9	59.3/23.3
D HEAD TUBE ANGLE (DEGREES)	70.5°	70.5°	70.5°	71°	71.5°	72°
E SEAT TUBE ANGLE (DEGREES)	76°	75°	75°	74.5°	73°	72.5°
F STANDOVER (CM)	68.9	74.5	75.9	79.3	83.1	87.3
G HEAD TUBE LENGTH (CM)	14	14	15	17	20	23
H WHEELBASE (CM/IN)	100.5	102.4	103.7	104.7	105.7	108.4
I FRONT CENTER (CM)	57.5	60	61.1	62.2	63.2	65.9
J CHAIN STAY LENGTH (CM)	43.5	★	★	★	★	★
K BOTTOM BRACKET DROP (CM)	5.1	7	★	★	★	★
L BOTTOM BRACKET HEIGHT (CM)	27.4	★	★	★	★	★
M FORK RAKE (CM)	5	★	★	★	★	★
N TRAIL (CM)	6.2	6.9	6.9	6.6	6.2	5.9

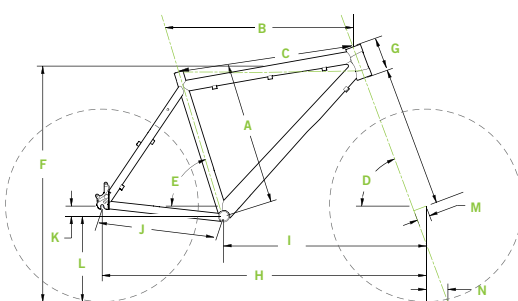

★ Indicates same as previous

Specifications subject to change without notice.

RECREATION/URBAN GEOMETRY

ADVENTURE

SPECIFICATIONS	SMALL	MEDIUM	LARGE	X-LARGE	JUMBO
A SEAT TUBE LENGTH OVERALL (CM/IN)	35.6/14.0	40.6/16.0	45.7/18.0	53.3/21.0	61.0/24.0
B SEAT TUBE ANGLE (DEGREES)	70°	★	★	★	★
C HEAD TUBE ANGLE (DEGREES)	69°	★	★	★	★
D HORIZONTAL TOP TUBE LENGTH (CM)	56.5	57.2	58	59	60
E CHAIN STAY LENGTH (CM)	46.5	★	★	★	★
F FORK RAKE (CM)	4.5	★	★	★	★
G BOTTOM BRACKET HEIGHT (CM)	28.0	★	★	★	★
H WHEELBASE (CM)	105.4	106.2	107.1	108.2	109.4
I TRAIL (CM)	8.5	★	★	★	★
J STANDOVER HEIGHT (CM)	70	73.2	77.2	82.2	86.3
K BOTTOM BRACKET DROP (CM)	6.8	★	★	★	★
L FRONT CENTER (CM)	59.8	60.6	61.4	62.3	63.7
M HEAD TUBE LENGTH (CM)	13.6	13.6	15.6	17.1	17.1

ADVENTURE 26"

SPECIFICATIONS	SMALL	MEDIUM	LARGE	X-LARGE	JUMBO
A SEAT TUBE LENGTH OVERALL (CM/IN)	35.6/14.0	40.6/16.0	45.7/18.0	53.3/21.0	61.0/24.0
B SEAT TUBE ANGLE (DEGREES)	70°	★	★	★	★
C HEAD TUBE ANGLE (DEGREES)	69°	★	★	★	★
D HORIZONTAL TOP TUBE LENGTH (CM)	55	55.7	56.5	58	59.5
E CHAIN STAY LENGTH (CM)	45.7	★	★	★	★
F FORK RAKE (CM)	4.5	★	★	★	★
G BOTTOM BRACKET HEIGHT (CM)	30.3	★	★	★	★
H WHEELBASE (CM)	104.2	105.0	105.9	107.6	109.2
I TRAIL (CM)	8.5	★	★	★	★
J STANDOVER HEIGHT (CM)	70.8	73.9	77.8	82.7	86.7
K BOTTOM BRACKET DROP (CM)	4.5	★	★	★	★
L FRONT CENTER (CM)	59.8	60.6	61.4	62.3	63.7
M HEAD TUBE LENGTH (CM)	13.6	13.6	15.6	17.1	17.1

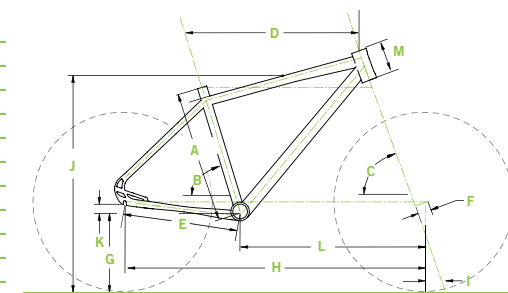

REGISTERED TRADEMARKS® OF CYCLING SPORTS GROUP, INC.:

Cannondale, the Cannondale "C" logo, the Cannondale train station logo, Daytripper, Claymore, CSGXCHANGE, Fatty, Gemini, Jekyll, Lefty, Perp, Prophet, Scalpel, Slice, Velopods, Synapse, System6, Systemsix, Hooligan, Felicity, SIMON, ELO, Felicity, Scarlet, SuperSix.

TRADEMARKS™ OF CYCLING SPORTS GROUP, INC.:

BB30, Beat Box, CAAD (Cannondale Advanced Aluminum Design), HeadShok, Hi-MOD, Hollowgram, "Fit, Features and Fashion", Naero, PowerPyramid, Quick, Q-Lab, RZ, SAVE, Si, Spidering, System Integration, BallisTec Carbon, SmartFormed Alloy, ECS-TC (Enhanced Center-Stiffness, Torsion Control) System, Zero Pivot, Lexi, Althea, Trigger, Narrow is Aero, Durathon and PopTop.

Liquigas is a registered trademark and used with their permission. Reve 2012 is a copyright of Reve/Velodramatic. FOX, FOX Racing Shox and Dyad RT2 are registered trademarks of FOX Factory Inc. and are used with their permission. Solo Air, RockShok, XLoc are registered trademarks of SRAM and are used with their permission. X-12 is a trademark of Syntace GmbH and is used with their permission. EVO is a trademark of Aprebic Industry Co. Ltd. and used under license.

Cannondale supports pro teams. We are grateful for the past and/or current support of: FSA, Mavic, SRAM (including Avid, Rockshox, Zipp), Lotto, Rudy Project, MeT, Nalini, Sidi, fi'zi:k, SRM, Speedplay, Schwalbe, Elite, Sci Con, Crankbrothers, Avid, Cyclocrossworld.com, Zipp, Grip Grab, Campagnolo, Shimano. Branding from these partners, based on sponsor agreements may be seen on photos in this catalog. Individual athletes may display other sponsored brands, based upon their own sponsorship agreements with those brands.

WWW.CANNONDALE.COM

Please visit [cannondale.com](http://www.cannondale.com) to learn more about Cannondale and the 2013 bikes! Specifications subject to change without notice.

Please refer to www.cannondale.com for the most recent specifications.

NO WEIGHTS?

Don't believe the hype. Scales differ, and marketing departments have been known to fib. The best way to compare bike weights is to head to your local bike shop. Grab two comparably spec'd and built bikes, and ask the proprietor for a scale. Hang 'em high, and see who's the lightest.

SPECIAL THANKS GOES TO:

- | | | |
|-----------------------------|----------------------------|---------------------------------|
| ALE DILULLO | MIKE KARCHER/WIX PIX | SMITH OPTICS |
| ARMIN KUSTENBRUCK | REBECCA MARSHALL | THULE |
| BETTINI PHOTO | ROBERTSON/VELODRAMATIC | OAKLEY |
| BRIAN VERNOR | SINCERE PHOTO AND DESIGN | OSPREY PACKS |
| DH PRODUCTIONS | WIL MATTHEWS | MAVIC |
| GARTH MILAN | WTB | ALL OF OUR MODELS |
| HAVERKORT DEKKER FOTOGRAFIE | KINGDOM TRAILS ASSOCIATION | OUR RIDERS |
| JAKE HAMM | DEER VALLEY RESORT | OUR VENDORS |
| JASON GOULD | WHITE PINE TOURING | OUR DEALERS |
| LIAM DORAN | NATIVE EYEWEAR | AND YOU FOR RIDING A CANNONDALE |
| MARCOTINIOLLO | | |

cannondale

CSG
CYCLING SPORTS GROUP™

DOREL

©8/2012 Cycling Sports Group, Inc.