

# SuperSix EVO

Owner's Manual Supplement



## **WARNING**

**READ THIS SUPPLEMENT AND YOUR  
CANNONDALE BICYCLE OWNER'S MANUAL.**

Both contain important safety information.  
Keep both for future reference.

## Safety Messages

In this supplement, particularly important information is presented in the following ways:



### **WARNING**

Indicates a hazardous situation which, if not avoided, may result in death or serious injury.

### **NOTICE**

Indicates special precautions that must be taken to avoid damage.

## Symbols:

Symbol	Name	Description
	Carbon gel/friction paste	Apply carbon gel (friction paste) KF115/
	NGLI-2 synthetic grease	Apply NGLI-2 synthetic grease.
	Medium-strength removable thread lock	Apply Loctite® 242 (blue) or equivalent.

## Cannondale Help Center

Our online Help Center contains helpful resources to consult about our bikes.



<https://cannondale.zendesk.com/hc/en-us>

---

## Cannondale Supplements

This manual is a “supplement” to your [Cannondale Bicycle Owner’s Manual](#).

This supplement provides additional and important model specific safety, maintenance, and technical information. It may be one of several important manuals/supplements for your bike; obtain and read all of them.

Please contact your Authorized Cannondale Dealer immediately if you need a manual or supplement or have a question about your bike. You may also contact us using the appropriate country/region/location information.

You can download Adobe Acrobat PDF versions of any manual/supplement from our website: <http://www.cannondale.com>.

## Contacting Cannondale

### Cannondale USA

Cycling Sports Group, Inc.  
1 Cannondale Way  
Wilton, CT 06897 USA  
1-800-726-BIKE (2453)

### CSG Europe (Woudenberg)

Cycling Sports Group Europe B.V.  
Geeresteinselaan 57  
3931JB Woudenberg  
The Netherlands

### International Distributors

Consult our website to identify the appropriate Cannondale Dealer for your region.

## CONTENTS

<b>Safety Information .....</b>	<b>4-7</b>
<b>Technical Information .....</b>	<b>8-23</b>
<b>Replacement Parts.....</b>	<b>24-25</b>
<b>Notes .....</b>	<b>26</b>

## Your Cannondale Dealer

To make sure your bike is serviced and maintained correctly, and that you protect applicable warranties, please coordinate all service and maintenance through your Authorized Cannondale Dealer.

### NOTICE

Unauthorized service, maintenance, or repair parts can result in serious damage and void your warranty.

## SAFETY INFORMATION

### Important Composites Message

#### WARNING

Your bike (frame and components) is made from composite materials also known as “carbon fiber.”

All riders must understand a fundamental reality of composites. Composite materials constructed of carbon fibers are strong and light, but when crashed or overloaded, carbon fibers do not bend, they break.

For your safety, as you own and use the bike, you must follow proper service, maintenance, and inspection of all the composites (frame, stem, fork, handlebar, seat post, etc.) Ask your Cannondale Dealer for help.

We urge you to read PART II, Section D. “Inspect For Safety” in your [Cannondale Bicycle Owner’s Manual](#) BEFORE you ride.

**You can be severely injured, paralyzed or killed in an accident if you ignore this warning.**

### Inspection & Crash Damage Of Carbon Frames/Forks

#### WARNING

##### **After A Crash Or Impact:**

Inspect frame carefully for damage. See PART II, Section D. Inspect For Safety in your [Cannondale Bicycle Owner’s Manual](#).

Do not ride your bike if you see any sign of damage, such as broken, splintered, or delaminated carbon fiber.

##### **Any of the following may indicate a delamination or damage:**

- An unusual or strange feel to the frame
- Carbon which has a soft feel or altered shape
- Creaking or other unexplained noises,
- Visible cracks, a white or milky color present in carbon fiber section

**Continuing to ride a damaged frame increases the chances of frame failure, with the possibility of injury or death of the rider.**

## Intended Use



The intended use of all models is ASTM CONDITION 1, High-Performance Road.

### WARNING

Please read your Cannondale Bicycle Owner's Manual for more information about Intended Use and Conditions 1-5.

## Servicing

### WARNING

**This supplement may include procedures beyond the scope of general mechanical aptitude.**

Special tools, skills, and knowledge may be required. Improper mechanical work increases the risk of an accident. Any bicycle accident has risk of serious injury, paralysis, or death.

**To minimize risk we strongly recommend that owners always have mechanical work done by an Authorized Cannondale Dealer.**

## Disc Brakes on Road Bikes

### WARNING

Relative to conventional rim brakes, disc brakes are less affected by water, do not wear or heat the rims and therefore are more consistent. Disc brakes also may be more powerful.

#### To minimize risk of injury or accidents:

- Understand that road bikes have a relatively small tire contact patch (part of the tire that touches the road). In order to apply the brakes safely and effectively, you may need more or less braking force in different situations. You need to take into account various road and weather conditions that can affect traction.
- Disc brakes are excellent, but not some kind of magic. Take some time riding your new disc brake road bike in lower risk circumstances to get used to the feel and performance of the disc brakes and tires.

**You can be severely injured, paralyzed or killed in an accident if you ignore this message.**

## Using a Trainer

Follow the trainer manufacturer instructions for the use of any required adapters.

Be particularly cautious with a carbon frame or fork. Carbon is relatively soft, not abrasion resistant. If there is any relative movement, carbon will wear quickly.

If you ride a trainer a lot, consider using an old bike: Corrosion from sweat will take its toll. Weight is irrelevant. Save wear on your expensive components.

Ask your dealer for help with trainers, the right one and the correct way to use it.

### NOTICE

**TRAINERS** - Improperly mounting a bike in a trainer, or using one that is not compatible with your particular bike frame can cause serious damage.

This kind of damage is not covered by the Cannondale Limited Warranty.

See “2-in-1 Trainer Thru Axle Installation Instructions 138252.pdf” at [www.cannondale.com](http://www.cannondale.com)

## Water Bottles

Side impacts to a water bottle or cage can result in damage to threaded inserts due to the leverage on a very small area. In a crash, certainly the last thing you should be worried about is saving the threaded inserts in your frame. However, when you are storing or transporting your bike, take steps to prevent situations where a water bottle may be hit or bumped by a strong force that would cause damage. Remove the bottle and cage when you are packing your bike for travel.

Periodically check the attachment of the bottle cage; tighten the cage bolts if necessary. Don't ride with a loose bottle cage.

A loose cage will damage the insert and possibly lead to the inserts pulling out.

It may be possible to repair a loose insert or to install another insert only if the frame is undamaged. Replacement requires the use of a special tool. If you notice damage to the threaded insert, please ask your Cannondale Dealer for help.

### NOTICE

An impact, crash, or loose bottle cage can result in damage to your frame. This kind of damage is not covered by the Cannondale Limited Warranty.

## Building Up A Frameset

Before building up a frameset, consult with your Cannondale Dealer and the component manufacturers and discuss your riding style, ability, weight, and interest in and patience for maintenance.

Make sure the components chosen are compatible with your bike and intended for your weight and riding style.

Generally speaking, lighter weight components have shorter lives. In selecting lightweight components, you are making a trade-off, favoring the higher performance that comes with less weight over longevity. If you choose more lightweight components, you must inspect them more frequently. If you are a heavier rider or have a rough, abusive, or "go for it" riding style, buy heavy-duty components.

Read and follow the component manufacturers warnings and instructions.

## Tightening Torques

Correct tightening torques for the fasteners on your bicycle (e.g., bolts, screws, and nuts) are important for your safety and to maintain the durability and performance of your bicycle.

We urge you to have your dealer correctly torque all fasteners using a torque wrench. If you decide to torque fasteners yourself, always use a torque wrench.

### Find Tightening Torque Information :

The wide range of bicycle models and components used means that a listing of tightening torques would be out-of-date by the time it was published. Many fasteners should be installed with a thread locking adhesive such as Loctite®.

**To determine the correct tightening torque and any adhesive application for a fastener we ask you to check the following:**

- On-product torque markings.
- Torque specs in the component manufacturer's instructions shipped with your bicycle.
- Torque specs listed on the websites of component manufacturers.
- With your dealer. Dealers have access to current data and have experience with correct torques for most fasteners.

## TECHNICAL INFORMATION

### Specifications

Item	Specification
Head Tube	UPR: 1-1/8in, LWR: 1-1/4in
Headset	Integrated 1-1/8in-1-1/4in, IS42 Top IS47 Bottom
Bottom Bracket: Type/Width	BSA/68mm - <b>Sleeve required</b>
Front Derailleur	Braze-on
Seat Post:	0mm Offset: K26062
	20mm Offset: K26072
	Seatbinder: K26002
▲ Min. Seat Post Insert	65mm
Max. Seat Post Insert	44cm: 100mm 48cm: 140mm 51cm: 166mm 54cm: 190mm 56cm: 193mm 58cm: 205mm 61cm: 215mm
Tire Size x Max. Tire Width	700C x 34mm (measured)
Brakes: Mount Type / Min./Max. Rotor Dia.	FT: Flat Mount/140mm/160mm
	RR: Flat Mount/140mm/160mm
Axles: Type/Length	FT: Syntace 100mmxM12x1.0P, 122mm Overall Length RR: Syntace 142mmxM12x1.0P, 160mm Overall Length
Fork Offset	Size 44cm-54cm: 55mm Size 56cm-61cm: 45mm
▲ Intended Use	ASTM Condition 1: High-Performance Road
▲ Max. Weight Limit: Total (Rider+All Equipment)	285lbs/129kg

### Serial Number

Use the 7-digit serial number label (1) located on the bottom bracket to register your bike.

**Product Registration**  
[www.cannondale.com](http://www.cannondale.com)

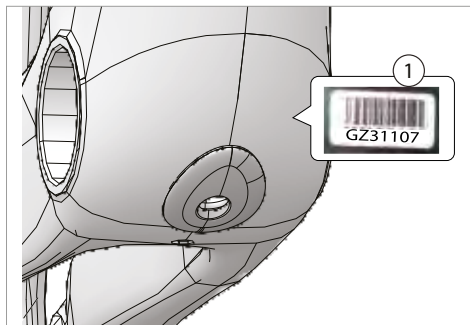



## Geometry

Dimensions = centimeter

\* = same spec.

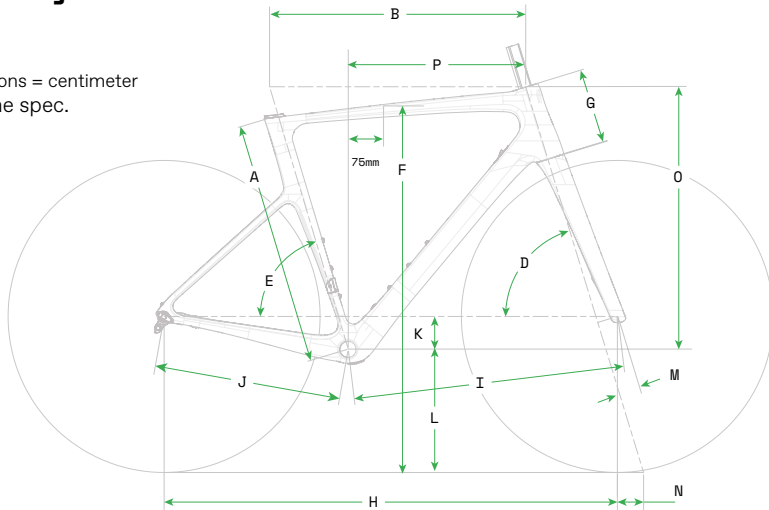

	Size	44	48	51	54	56	58	61
	Wheel Size	700c	700c	700c	700c	700c	700c	700c
A	Seat Tube Length	40.0	43.8	47.7	51.5	53.4	56.7	60.0
B	Top Tube Horizontal	51.2	52.0	52.8	54.6	56.2	57.8	60.3
C	Top Tube Actual	46.9	47.9	48.9	50.9	52.3	54.1	56.4
D	Head Tube Angle	70.9°	71.2°	71.2°	71.2°	73.0°	73.0°	73.0°
E	Seat Tube Angle Effective	74.3°	74.3°	74.3°	73.7°	73.3°	72.9°	72.3°
E'	Seat Tube Angle Actual	74.3°	74.3°	74.3°	73.7°	73.3°	72.9°	72.3°
F	Standover	69.8	72.7	75.6	78.8	80.7	83.6	86.6
G	Head Tube Length	10.0	11.4	13.0	15.4	16.5	18.8	22.0
H	Wheelbase	98.1	98.7	99.6	101.0	99.4	100.7	102.4
I	Front Center	58.2	58.9	59.8	61.1	59.4	60.7	62.4
J	Chain Stay Length	41.0	41.0	41.0	41.0	41.0	41.0	41.0
K	Bottom Bracket Drop	7.4	7.4	7.4	7.2	7.2	6.9	6.9
L	Bottom Bracket Height	26.8	26.8	26.8	27.1	27.1	27.3	27.3
M	Fork Rake	5.5	5.5	5.5	5.5	4.5	4.5	4.5
N	Trail	6.0	5.8	5.8	5.8	5.8	5.8	5.8
O	Stack	50.5	52.0	53.5	55.5	57.5	59.5	62.5
P	Reach	37.0	37.4	37.8	38.4	38.9	39.5	40.3

## Shimano Di2 Battery

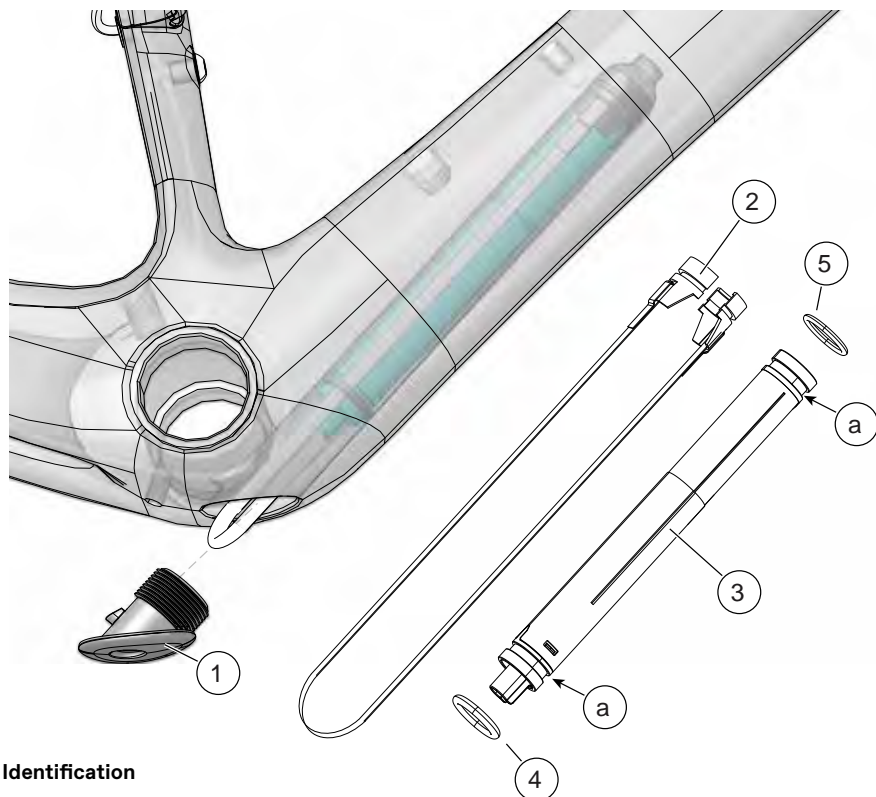

### Identification

1. BB plug
2. Tether
3. Di2 battery
4. O-ring, larger
5. O-ring, smaller

a. groove

### NOTICE

**Do not allow the tether to dangle outside the frame opening.**

**Do not insert other objects into the frame battery pocket.**

- The tethering assembly is compatible with Shimano BT\_DN110 Di2 battery.
- The tether is fitted to the battery and secured onto it by the O-rings. Be sure that the O-rings are seated in the grooves.
- After the battery is inserted into the frame, fold up the tether end loop and tuck it into the opening. Insert the BB plug; make sure it is inserted completely. The hole in the BB plug is simply a drain to allow collected moisture to exit.

## Routing 1

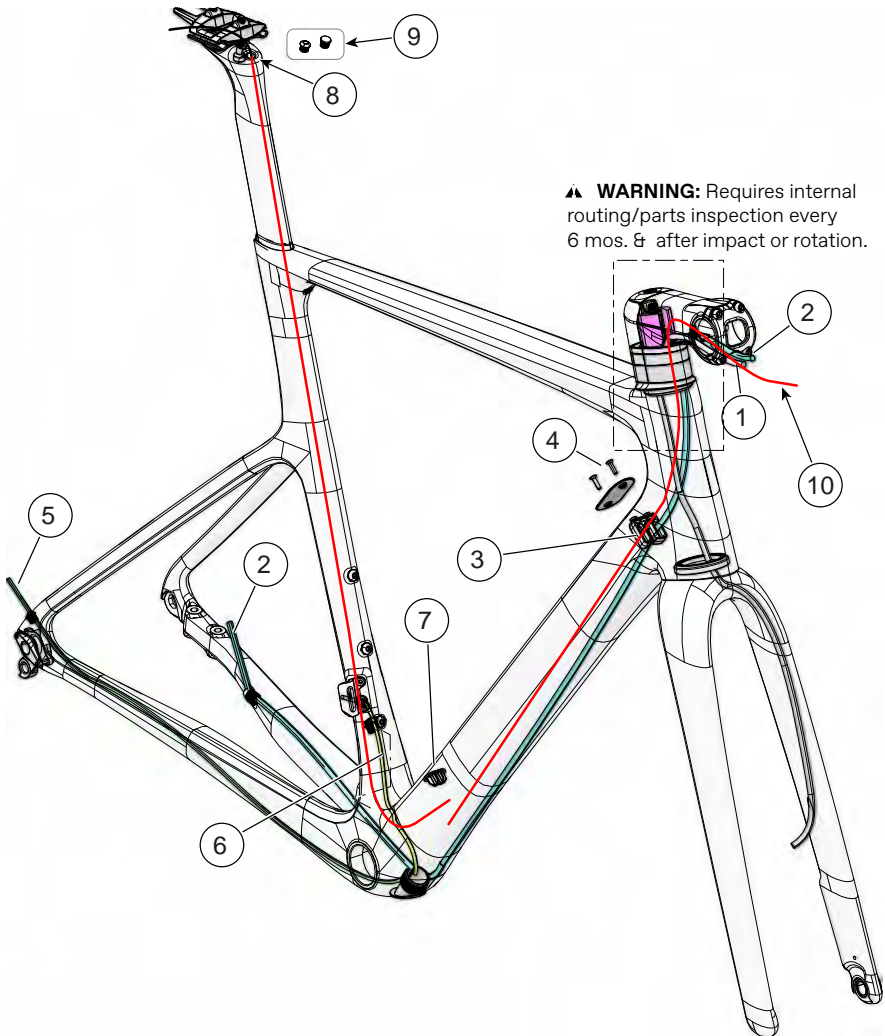

### Identification

- |                         |                                 |                      |
|-------------------------|---------------------------------|----------------------|
| 1. Front brake hose     | 6. Front derailleur wire        | 10. SmartSense cable |
| 2. Rear brake hose      | 7. SmartSense port cover        |                      |
| 3. DT cable guide       | 8. SmartSense cable             |                      |
| 4. DT cover             | 9. SmartSense seatpost grommets |                      |
| 5. Rear derailleur wire |                                 |                      |

## Routing 2

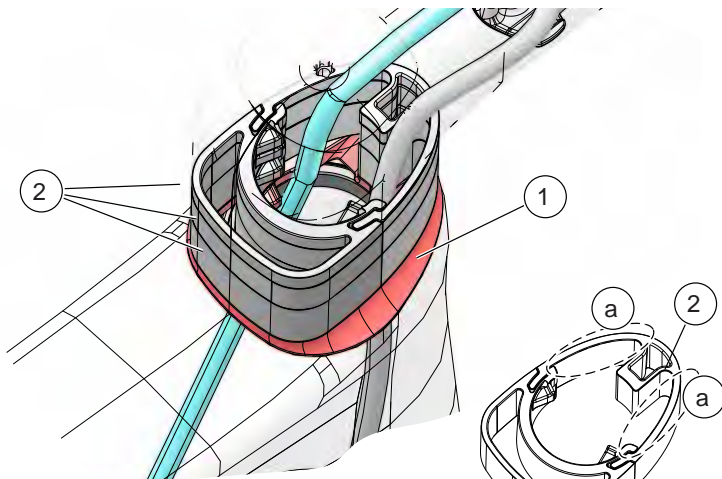

### Identification

1. Headset bearing dust cover
2. 2-piece spacers
- a. Clearance area for brake hose and electric wire

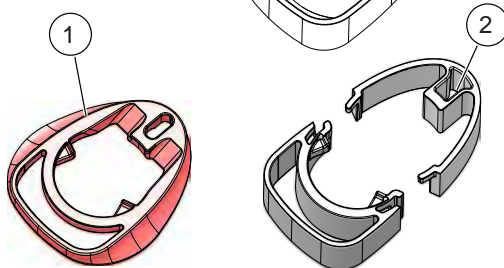

### NOTICE

Hose lengths must be carefully selected. Avoid both too long and too short, because incorrect lengths can limit steering angle and damage hoses.

## Downtube (DT) Port Guides / Routing

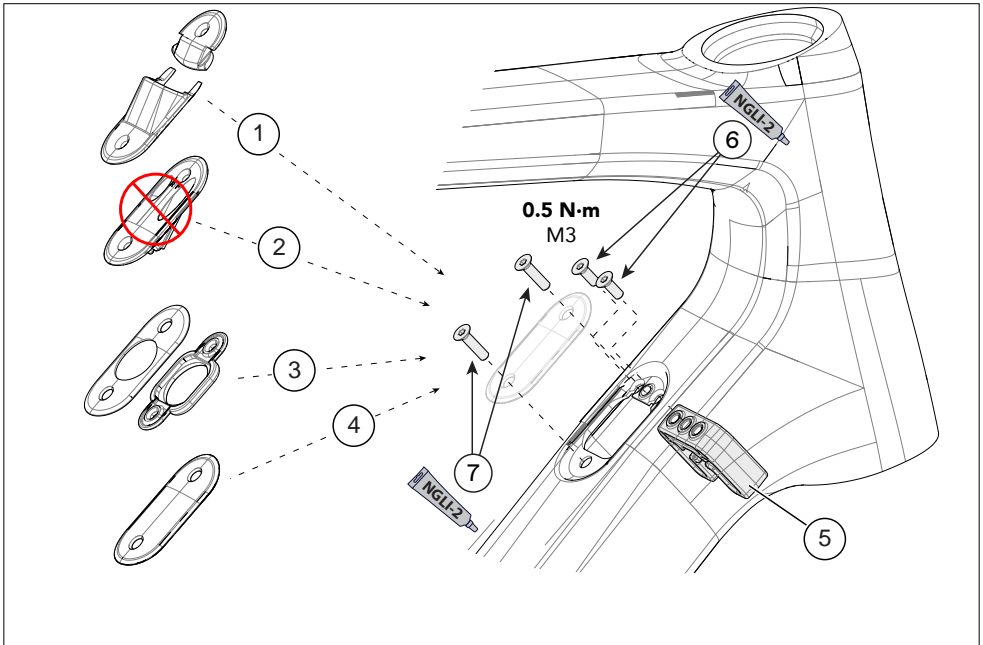

### Identification

- |   |                              |                          |
|---|------------------------------|--------------------------|
| 1. 4-cable port cover                         | 3. Shimano Di2 port cover    | 6. Guide screws, M3 × 8  |
| 2. Mechanical shift housing stop (DO NOT USE) | 4. Wireless shifting cover   | 7. Cover screws, M3 × 12 |
|   | 5. Internal brake hose guide |                          |

## Rear Derailleur Mount (RD)

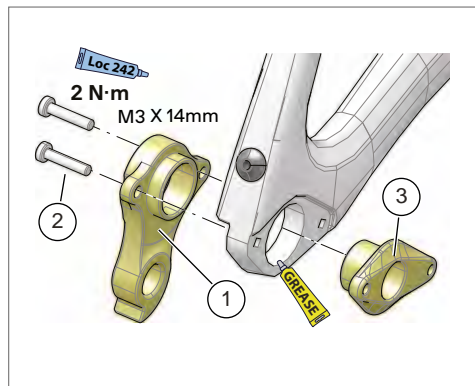

1. RD Hanger
2. Screws
3. Thru axle nut

### To replace:

1. Remove the rear axle.
2. Remove the screws (2).
3. Remove the hanger (1) and thru axle nut (3).
4. Clean the area around the dropout and inspect the frame carefully for any cracks or damage. If you find damage, have the frame inspected by your Cannondale Dealer .  
  
If the frame is not damaged, apply a light film of grease between the frame and hanger. This will help minimize any noise or “creaking” that might result from slight movement between the frame and hanger.
5. Slide the new hanger and thru axle nut onto the frame.
6. Apply Loctite® 242 (or medium strength thread lock) to the screw threads and tighten to the specified torque. Do not over-tighten.

## SmartSense

As an option, this frame supports installation of a Cannondale SmartSense.

### What is SmartSense?

SmartSense is a system of powered accessories. Each accessory shares the same data communication and same rechargeable battery. The behavior of each accessory can be programmed and controlled independently or coordinated with any other component via the Cannondale App.

### SmartSense Owner's Manual



<https://www.cannondale.com/-/media/files/manual-uploads/cy22/138691-rev1-cd-cy22-smartsense-owners-manual-020922.ashx>

The SmartSense Owner's Manual contains important safety information and information regarding how to identify, to set up, and to operate any installed/attached SmartSense-compatible components.

## Bottom Bracket

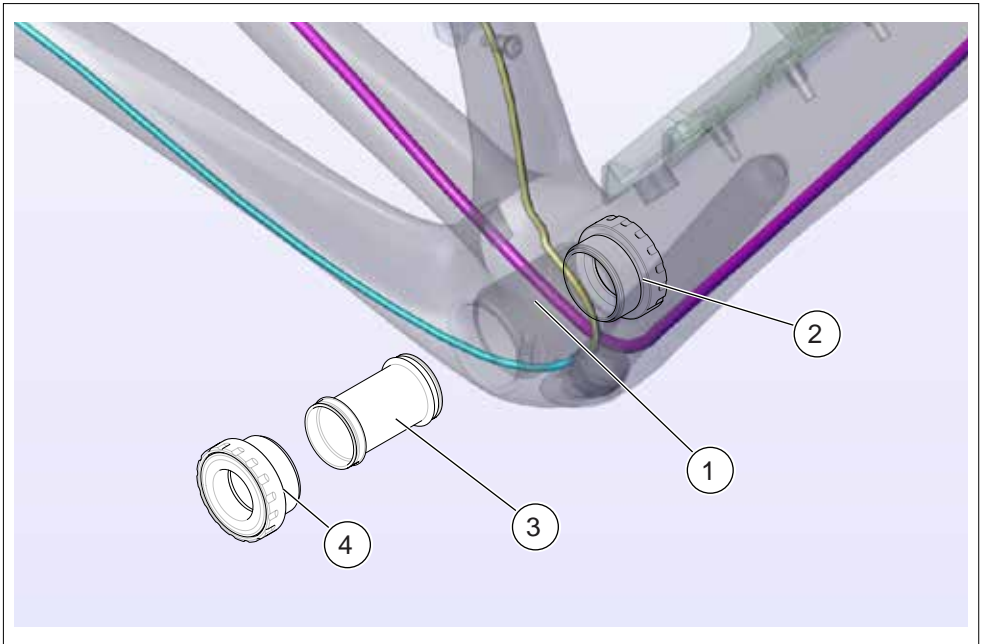

### Identification

1. Bottom bracket
2. Left bearing cup
3. Sleeve
4. Right bearing cup

### WARNING

This frame requires a bottom bracket with integrated sleeve to prevent spindle contact with internal wiring or hoses! Do not remove or omit the sleeve during assembly or service.

## Seat Post

### To remove seat post:

1. Turn the binder screw with a 4mm hex key counter-clockwise to loosen the clamp. When clamp is loose, simply lift the seat post up out of the seat tube.

### To install the seat post:

1. Remove the binder clamp, clean it and the frame pocket, then apply fresh grease to the surface that will fit against the frame, as shown on the next page. Reinstall the binder clamp into the frame pocket.
2. Apply fresh carbon friction paste to the inserted section of the seat post and inside the seat tube, including the surface of the binder clamp which contacts the seat post.
3. Insert the seat post into the frame.
4. Set the saddle height, observing the minimum insert and within the limits of the maximum insert for the frame and tighten the clamp screw to 8 Nm.
5. Lower the rubber cover to the frame.

### To adjust height:

1. Insert a 4mm hex into the clamp screw.
2. Loosen the binder screw sufficiently to move the seat post up or down in the seat tube.
3. Set the seat post position.
4. Tighten the binder clamp screw to 8 Nm.

### To remove binder:

1. Remove the seat post.
2. Using a 4mm hex key, turn the screw clockwise (tightening it) until the binder clamp disengages from the threaded base and can be lifted up out of the seat tube. Take care not to let the binder clamp fall into the seat tube.

### Maintenance

Periodically remove the seat post and the binder clamp assembly to clean, to inspect for damage, and to renew the application of grease and of carbon gel.

#### NOTICE

Do not exceed the specified torque.

Do not use any spray cleaners or solvents to clean.

Do not adjust a seat post so it is bottomed out in the frame.

For more information about carbon fiber seat posts, see also "Care and Maintenance of Carbon Fiber Seat Posts" in your Cannondale Bicycle Owner's Manual.



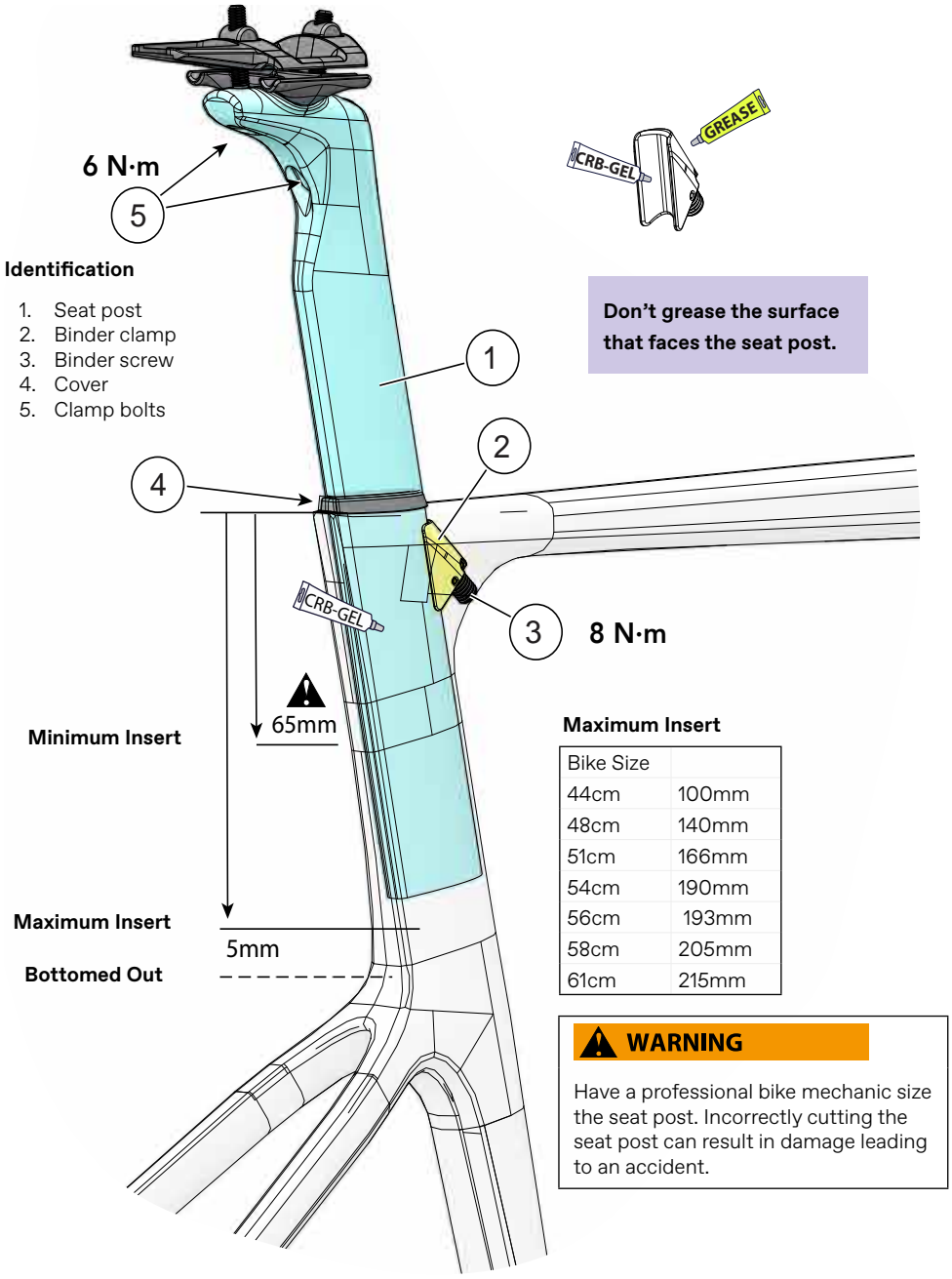

**Identification**

- 1. Seat post
- 2. Binder clamp
- 3. Binder screw
- 4. Cover
- 5. Clamp bolts

**Don't grease the surface that faces the seat post.**

**Maximum Insert**

Bike Size	Maximum Insert
44cm	100mm
48cm	140mm
51cm	166mm
54cm	190mm
56cm	193mm
58cm	205mm
61cm	215mm

**⚠ WARNING**

Have a professional bike mechanic size the seat post. Incorrectly cutting the seat post can result in damage leading to an accident.

## Delta Fork Headset Compression Assembly

The Supersix EVO utilizes a delta fork, a fork with a triangular steerer. Only a delta fork headset compression assembly can be used.

### Filler Pieces

- The SystemBar uses the assembly with fillers that are pink in color.
- The Conceal Stem uses the assembly with fillers that are black in color.
- The foot of the filler pieces point down and positioned at the rear as shown in the following example illustrations.

### Sizing And Cutting A Delta Fork

The Cannondale Service Instructions Delta Fork Headset Compression Assembly define the correct method for cutting and preparing the delta fork.

### **WARNING**

The headset, stem, handlebar spacers, and compression assembly of your bike are parts of a system designed to work together. It is important to your safety that you do not alter, remove or omit parts, or assemble the system incorrectly.

This manual does not include instructions for servicing. This is why you should have work on the system performed by a professional bicycle mechanic with the experience, tools, and information to complete any needed service.

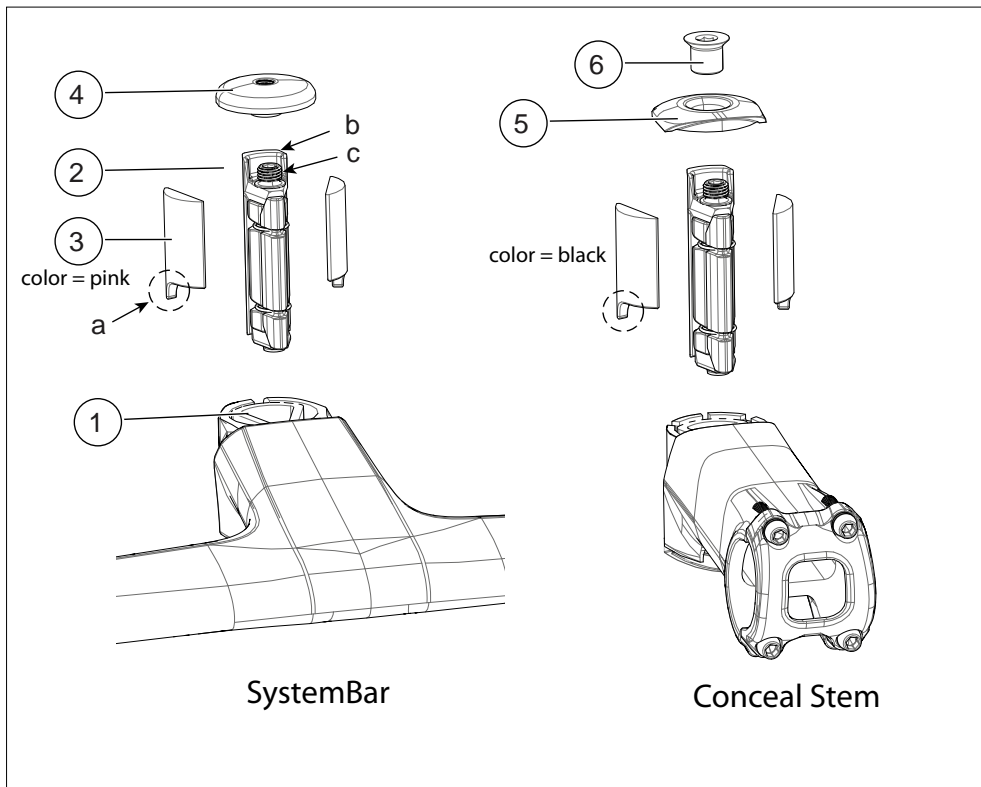

**Identification**

- |                        |                      |                         |
|------------------------|----------------------|-------------------------|
| 1. Delta fork steerer  | 5. SystemBar top cap | a. Filler foot          |
| 2. Delta expander      | 6. Conceal top cap   | b. Expander lip         |
| 3. Delta Filler pieces | 7. Conceal cap bolt  | c. Expander fixing bolt |
| 4. Expander bolt       |                      |                         |

Part Number	Description
K35063	SystemBar Delta Expander Plug
K3508310	SystemBar Delta Filler Pieces L+R PNK
K35051	Conceal Delta Expander Plug
K3507310	Conceal Delta Filler Pieces L+R BLK

## SystemBar R-One

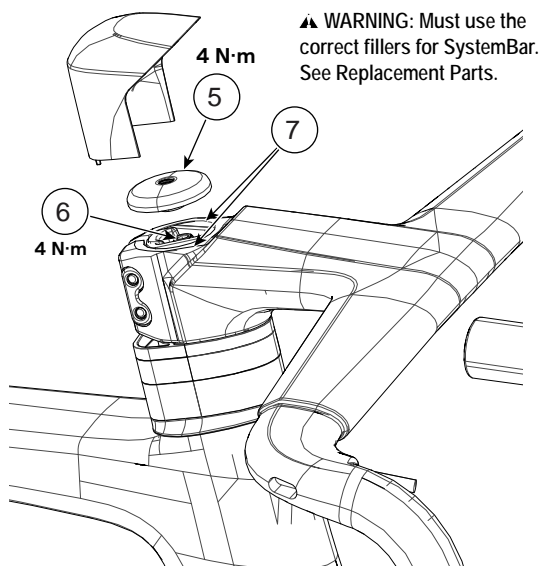
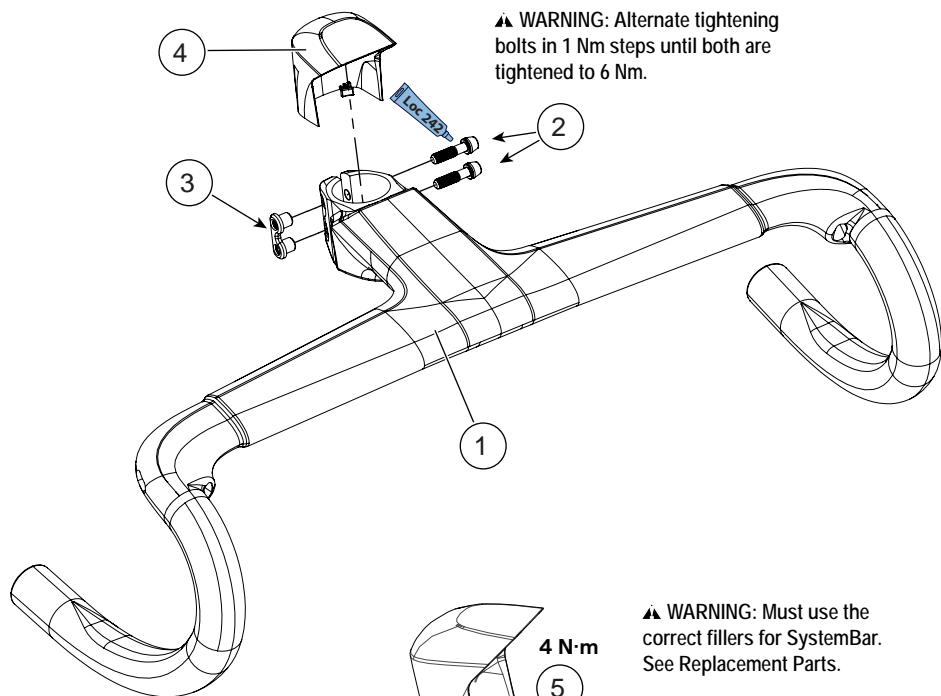

### Identification

1. Handlebar
2. Handlebar bolts M5X18
3. Dogbone nut
4. Stem cover
5. Top cap for SystemBar
6. Delta fork headset compression assembly
7. Fillers

## SystemBar R-One Mount

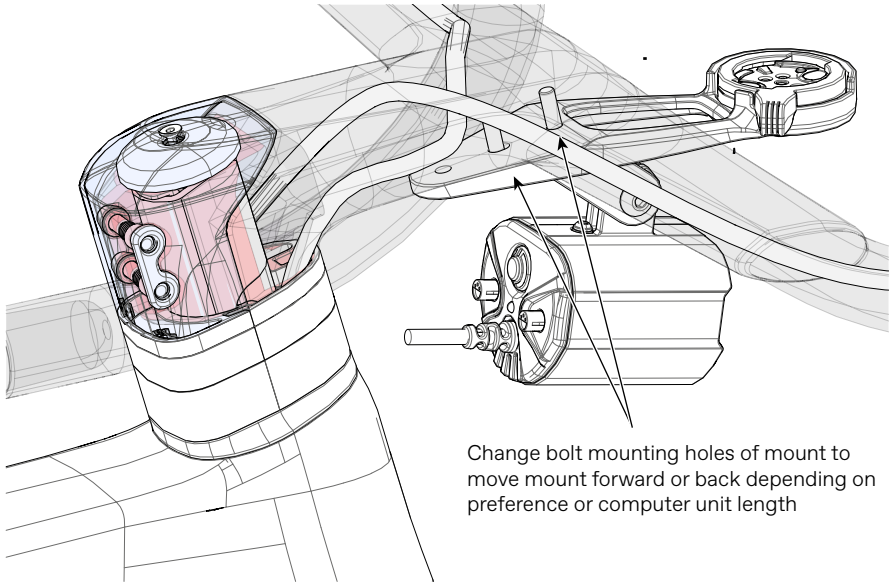

### Identification

1. Garmin mount cockpit
2. Light mount cockpit
3. Quarter turn mount  
**Garmin**
4. Button head cap screw  
M5×18
5. Socket head cap screw  
M3×8
6. Base puck
7. Quarter turn mount  
**Wahoo**
8. Socket head cap screw  
low M4×16

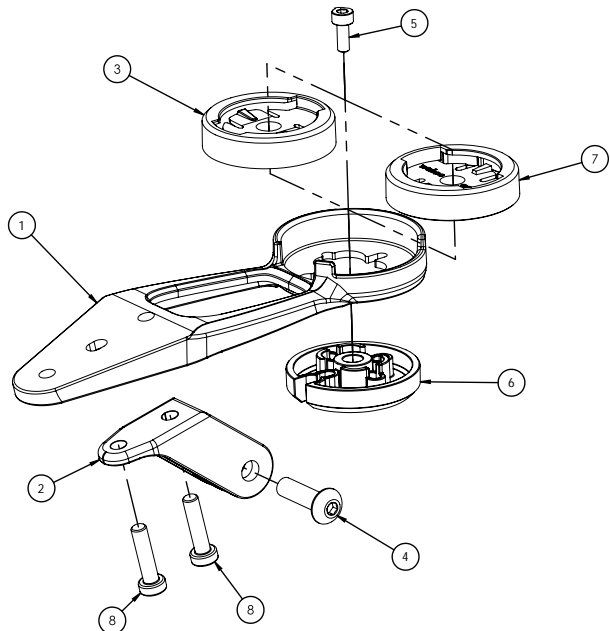

## C1 Conceal Stem

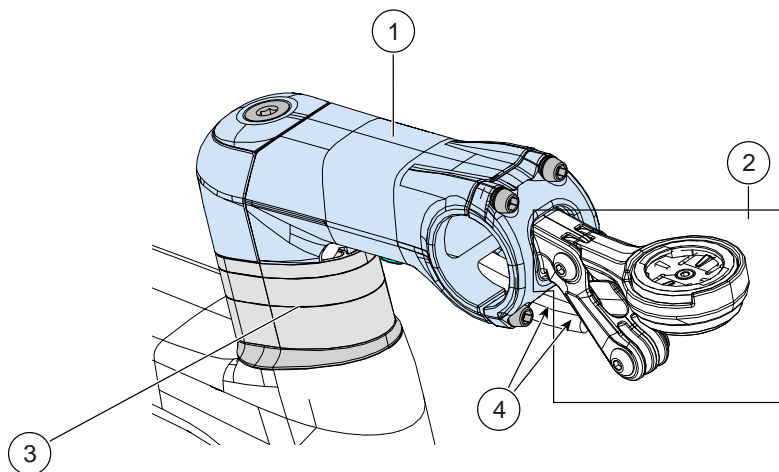

### Identification

1. C1 Conceal stem
2. Accessory mount
3. Spacers
4. Brake hoses
5. Delta fork headset compression assembly

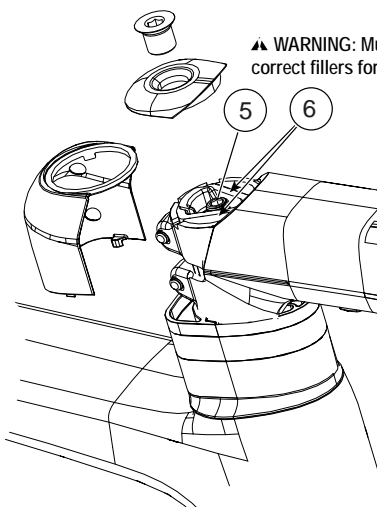

▲ WARNING: Must use correct fillers for Conceal stem.

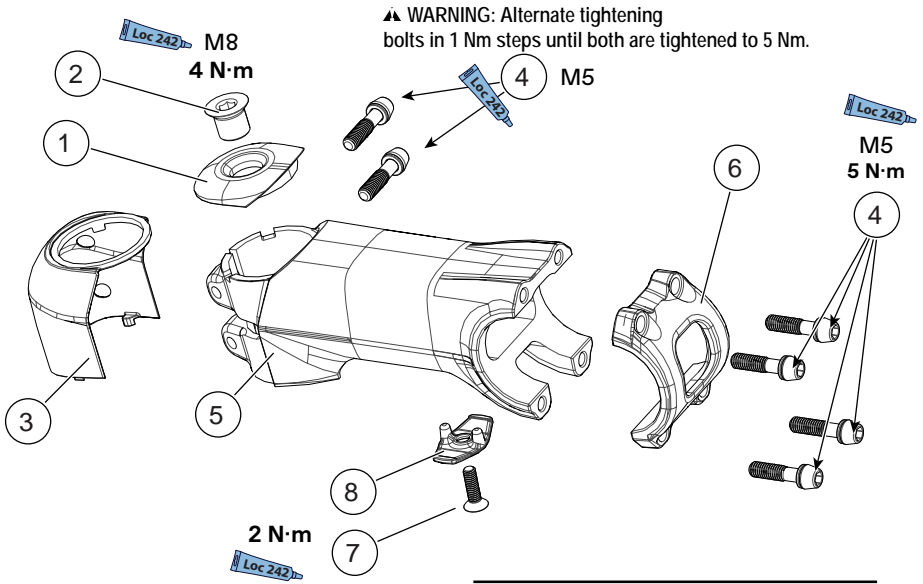

**Identification**

1. Top cap
2. Compression nut
3. Cover
4. Faceplate bolts
5. Stem body
6. Face plate
7. Screw M4 × 12
8. Cable clip
9. Friction flange
10. Computer Mount
11. Bolt M5 × 18
12. Quarter turn mount, Garmin
13. Quarter turn mount, Wahoo
14. Base puck
15. Screw M3 × 8
16. Light mount

**C1 Conceal Stem Mount**

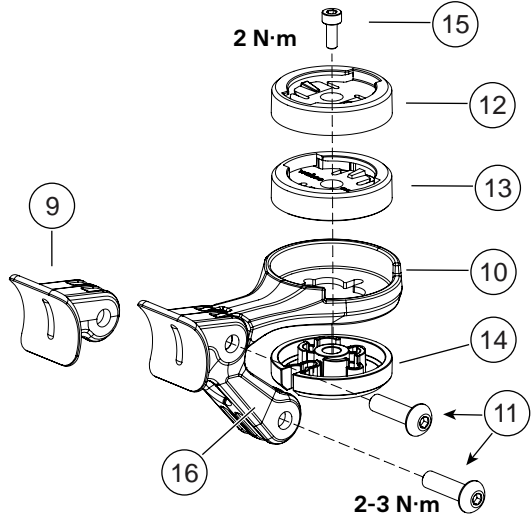

### REPLACEMENT PARTS

#### SystemBar R-One

#### C1 Conceal Stem

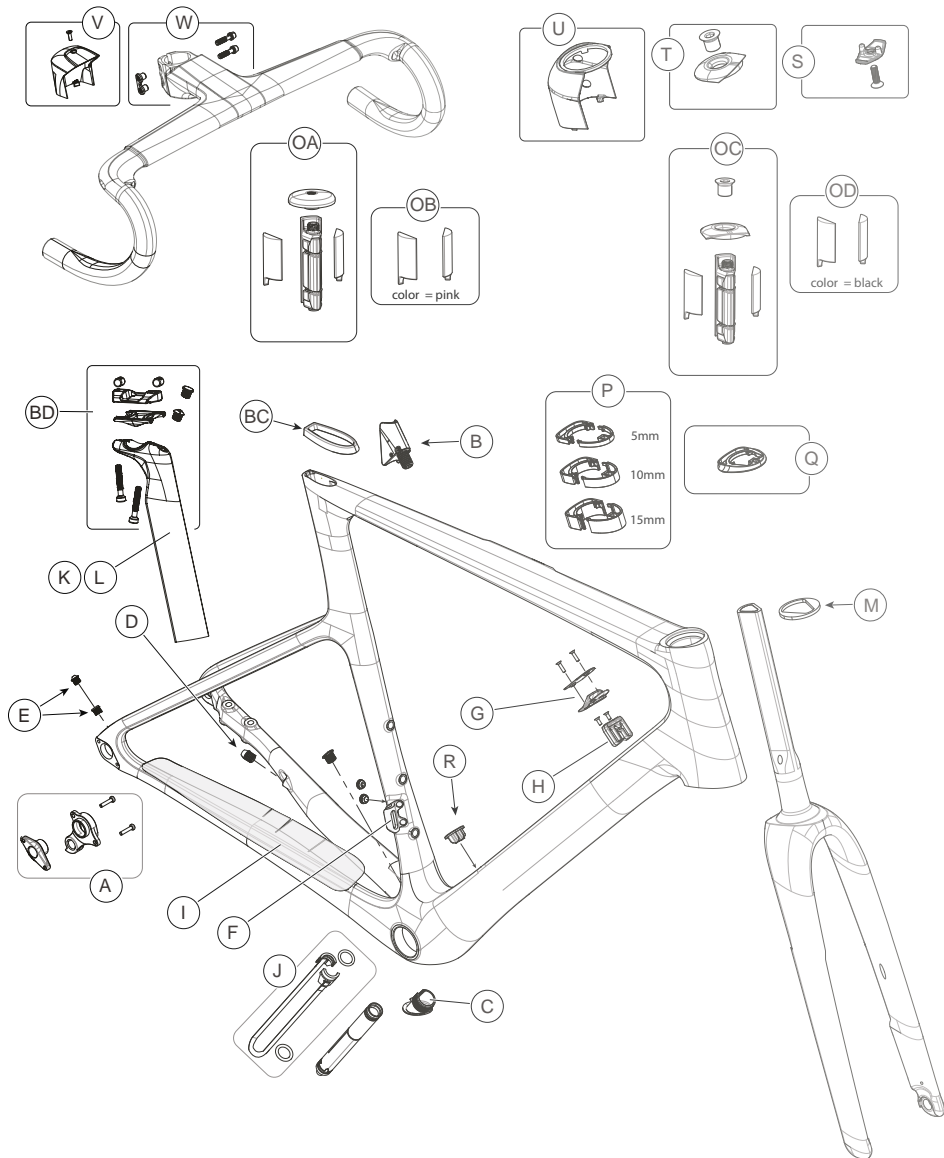



ID	Part Number	Description
A	K33023	Derailleur Hanger TA ST 2p 093
B	K26002	S6 EVO Internal Seatbinder V3
BC	K26053	EVO4 Seatpost Grommet
BD	K26092	EVO v4 Smartsense Rail Clamp w/Hardware
C	K32142	S6 EVO BB Grommets
D	KP449/	Rubber Brake Housing Grommets
E	K32170	S6 EVO Frame Grommets
F	K33022	S6 EVO Fd Hanger V4
G	K32171	DT Cable Switch Plate
H	K32152	S6 EVO DT Cable Keeper
I	K34232	S6 EVO CS Protector
J	K14102	S6 EVO DT Battery Mount Electronic
K	K26062	S6 EVO CRB Seatpost V4 330mm 0 O/Set
L	K26072	S6 EVO CRB Seatpost V4 330mm 20 O/Set
M	K28042	Delta Preload Stem Spacer Kit
P	K28062	Conceal Spacer Kit: 5mm QTY 3/ 10mm QTY 2 / 15mm QTY 1
Q	K28052	Conceal Bearing Cap
S	K28072	C1 Conceal Cable Clamp
T	K35042	C1 Conceal Top Cap & Bolt
U	K28142	C1 Conceal Cover
V	K28092	One Piece Handlebar Stem Cover
W	K28102	One Piece Handlebar Bolts W/Dogbone Nut/Bolts
R	K32172	10×17 DT Grommets Qty5
OA	K35063	SystemBar Delta Expander Plug
OB	K3508310	SystemBar Delta Filler Pieces L+R PNK
OC	K35051	Conceal Delta Expander Plug
OD	K3507310	Conceal Delta Filler Pieces L+R BLK
--	CK8067U000S	Syntace Ta 100×12×1.0p, Bolt 122 mm
--	K83051	Adjustable Lever Syntace 142×12 160mm

“--” - Item not pictured

www.cannondale.com  
© 2023 Cycling Sports Group  
SuperSix EVO OMS  
151901 Rev. 1 (03/23)

CANNONDALE USA  
Cycling Sports Group, Inc.  
1 Cannondale Way,  
Wilton CT, 06897, USA  
1-800-726-BIKE (2453)  
www.cannondale.com

CSG EUROPE  
Cycling Sports Group Europe B.V.  
Geeresteinselaan 57  
3931JB Woudenberg  
The Netherlands  
service@cyclingsportsgroup.com

CSG UK  
Cycling Sports Group  
Vantage Way, The Fulcrum,  
Poole, Dorset, BH12 4NU  
+44 (0)1202732288  
sales@cyclingsportsgroup.co.uk