

CAAD13

Owner's Manual Supplement



WARNING

**READ THIS SUPPLEMENT AND YOUR
CANNONDALE BICYCLE OWNER'S MANUAL.**

Both contain important safety information. Keep both for future reference.

Safety Messages

In this supplement, particularly important information is presented in the following ways:

WARNING

Indicates a hazardous situation which, if not avoided, may result in death or serious injury.

NOTICE

Indicates special precautions that must be taken to avoid damage.

The following symbols are used in this manual:

Symbol	Name	Description
	NGLI-2 synthetic grease	Apply NGLI-2 synthetic grease.
	Carbon gel	Apply carbon gel (friction paste) KF115/
	Medium-strength removable thread lock	Apply Loctite® 242 (blue) or equivalent.

Cannondale Supplements

This manual is a “supplement” to your [Cannondale Bicycle Owner’s Manual](#).

This supplement provides additional and important model specific safety, maintenance, and technical information. It may be one of several important manuals/supplements for your bike; obtain and read all of them.

Please contact your Authorized Cannondale Dealer immediately if you need a manual or supplement, or have a question about your bike. You may also contact us using the appropriate country/region/location information.

You can download Adobe Acrobat PDF versions of any manual/supplement from our website: <http://www.cannondale.com>.

Contacting Cannondale

Cannondale USA

Cycling Sports Group, Inc.
1 Cannondale Way,
Wilton, CT 06897 USA
1-800-726-BIKE (2453)

Cannondale Europe

Cycling Sports Group Europe B.V
Mail: Postbus 5100
Visits: Hanzeport 27
7575 DB, Oldenzaal Netherlands

International Distributors

Consult our website to identify the appropriate Cannondale Dealer for your region.

CONTENTS

Safety Information	2-5
Technical Information	6-19
Replacement Parts.....	20

Your Cannondale Dealer

To make sure your bike is serviced and maintained correctly, and that you protect applicable warranties, please coordinate all service and maintenance through your Authorized Cannondale Dealer.

NOTICE

Unauthorized service, maintenance, or repair parts can result in serious damage and void your warranty.

SAFETY INFORMATION

Important Composites Message

WARNING

Your bike (frame and components) is made from composite materials also known as “carbon fiber.”

All riders must understand a fundamental reality of composites. Composite materials constructed of carbon fibers are strong and light, but when crashed or overloaded, carbon fibers do not bend, they break.

For your safety, as you own and use the bike, you must follow proper service, maintenance, and inspection of all the composites (frame, stem, fork, handlebar, seat post, etc.) Ask your Cannondale Dealer for help.

We urge you to read PART II, Section D. “Inspect For Safety” in your [Cannondale Bicycle Owner's Manual](#) BEFORE you ride.

You can be severely injured, paralyzed or killed in an accident if you ignore this warning.

Inspection & Crash Damage Of Carbon Frames/Forks

WARNING

After A Crash Or Impact:

Inspect frame carefully for damage. See PART II, Section D. Inspect For Safety in your [Cannondale Bicycle Owner's Manual](#).

Do not ride your bike if you see any sign of damage, such as broken, splintered, or delaminated carbon fiber.

Any of the following may indicate a delamination or damage:

- An unusual or strange feel to the frame
- Carbon which has a soft feel or altered shape
- Creaking or other unexplained noises,
- Visible cracks, a white or milky color present in carbon fiber section

Continuing to ride a damaged frame increases the chances of frame failure, with the possibility of injury or death of the rider.

Intended Use



The intended use of all models is ASTM CONDITION 1, High-Performance Road.

WARNING

Please read your [Cannondale Bicycle Owner's Manual](#) for more information about Intended Use and Conditions 1-5.

Servicing

WARNING

This supplement may include procedures beyond the scope of general mechanical aptitude.

Special tools, skills, and knowledge may be required. Improper mechanical work increases the risk of an accident. Any bicycle accident has risk of serious injury, paralysis or death.

To minimize risk we strongly recommend that owners always have mechanical work done by an Authorized Cannondale Dealer.

Disc Brakes on Road Bikes

WARNING

Relative to conventional rim brakes, disc brakes are less affected by water, do not wear or heat the rims and therefore are more consistent. Disc brakes also may be more powerful.

To minimize risk of injury or accidents:

- Understand that road bikes have a relatively small tire contact patch (part of the tire that touches the road). In order to apply the brakes safely and effectively, you may need more or less braking force in different situations. You need to take into account various road and weather conditions that can affect traction.
- Disc brakes are excellent, but not some kind of magic. Take some time riding your new disc brake road bike in lower risk circumstances to get used to the feel and performance of the disc brakes and tires.

You can be severely injured, paralyzed or killed in an accident if you ignore this message.

Cutting a Seat Post

WARNING

THE SEAT POST MUST ONLY BE CUT BY A PROFESSIONAL BIKE MECHANIC. Incorrectly cutting the seat post can result in damage leading to an accident.

Trainers

If you ride a trainer that requires removal of the front wheel and clamps the fork dropouts: Be sure your fork quick release is tight! Relative movement will wear parts, weaken and damage your bike.

If you ride a trainer that holds the bike up by clamping the rear quick release between two cones: Take off the lightweight quick release that came with your bike. Substitute a heavy, classic all steel quick release and clamp it tight! Relative movement will wear parts, weaken and damage your bike. Note that many modern quick releases will not fit the clamping cones in this kind of trainer because their shapes are incompatible.

For thru axles, make sure you follow the trainer manufacturer instructions for the use of any required adapters.

Be particularly cautious with a carbon frame or fork. Carbon is relatively soft, not abrasion resistant. If there is any relative movement, carbon will wear quickly.

If you ride a trainer a lot, consider using an old bike: Corrosion from sweat will take its toll. Weight is irrelevant. Save wear on your expensive components.

Ask your dealer for help with trainers, the right one and the correct way to use it.

NOTICE

TRAINERS - Improperly mounting a bike in a trainer, or using one that is not compatible with your particular bike frame can cause serious damage.

WATER BOTTLES - An impact, crash, or loose bottle cage can result in damage to your frame.

These kinds of damage is not covered by the Cannondale Limited Warranty.

Water Bottles

Side impacts to a water bottle or cage can result in damage to threaded inserts due to the leverage on a very small area. In a crash, certainly the last thing you should be worried about is saving the threaded inserts in your frame. However, when you are storing or transporting your bike, take steps to prevent situations where a water bottle may be hit or bumped by a strong force that would cause damage. Remove bottle and cage when you are packing your bike for travel.

Periodically check the attachment of the bottle cage; tighten the cage bolts if necessary. Don't ride with a loose bottle cage. Riding with loose cage bolts can produce a rocking motion or vibration of the attached cage. A loose cage will damage the insert and possibly lead to the inserts to pull out.

It may be possible to repair a loose insert, or install another insert only if the frame is undamaged. Replacement requires the use of a special tool. If you notice damage to the threaded insert, please ask your Cannondale Dealer for help.

Building Up A Frame Set

Before building up a frame set, consult with your Cannondale Dealer and the component manufacturers, and discuss your riding style, ability, weight, and interest in and patience for maintenance.

Make sure the components chosen are compatible with your bike and intended for your weight and riding style.

Generally speaking, lighter weight components have shorter lives. In selecting lightweight components, you are making a trade-off, favoring the higher performance that comes with less weight over longevity. If you choose more lightweight components, you must inspect them more frequently. If you are a heavier rider or have a rough, abusive or "go for it" riding style, buy heavy duty components.

Read and follow the component manufacturers warnings and instructions.

Tightening Torques

Correct tightening torque for the fasteners (bolts, screws, nuts) on your bicycle is very important to your safety. Correct tightening torque for the fasteners is also important for the durability and performance of your bicycle. We urge you to have your dealer correctly torque all fasteners using a torque wrench. If you decide to torque fasteners yourself always use a torque wrench.

Find Tightening Torque Information :

The wide range of bicycle models and components used means that a listing of tightening torque would be out of date by the time it was published. Many fasteners should be installed with a thread locking adhesive such as Loctite®.

To determine correct tightening torque and any adhesive application for a fastener we ask you to check:

- Many components are marked. On-product marking is becoming common.
- Torque specs in the component manufacturers instructions shipped with your bicycle.
- Torque specs listed on the websites of component manufacturers.
- With your dealer. Dealers have access to current data and have experience with correct torque for most fasteners.

TECHNICAL INFORMATION

Frame Specifications

Item	Specification
Headset :	Integrated, UPR 1-1/8 in, LWR 1-1/4 in
Bottom Bracket: Type/Width	BB30A / 73 mm
Front Derailleur	Braze-on
Seat Post: Dia./Binder	Internal Wedge -
▲ Min. Seat Post Insert	65 mm
▲ Max. Seat Post Insert	44cm-140 mm, 48 cm - 179 mm, 51-62 cm (measure)
▲ Tire Size x Max. Width	DISC BRAKES: 700c x 30 mm (measured)
	RIM BRAKES: 700c x 28 mm (measured)
Brakes: Mount Type / Min/Max Rotor Dia. (mm)	DISC: Flat Mount 140 mm, 160 mm
	RIM: Direct Mount
Axles: Type / Hub Spacing / Length (mm)	DISC: Front: Speed Release TA Double Lead / 100 × 12/119, Rear: Speed Release TA Double Lead / 142 × 12 / 165
	RIM: Front: Quick release/ 100 × 9 Rear: Quick release 130 × 10
▲ Intended Use:	ASTM Condition 1
▲ Max. Weight Limit: Total (rider+all equipment)	285 lbs / 129 kg

Geometry

- A Seat Tube Length
- B Top Tube Horizontal
- D Head Tube Angle
- E Seat Tube Angle
- G Head Tube Length
- H Wheelbase
- I Front Center
- J Chain Stay Length
- K Bottom Bracket Drop
- L Bottom Bracket Height
- M Fork Rake
- N Trail
- O Stack
- P Reach

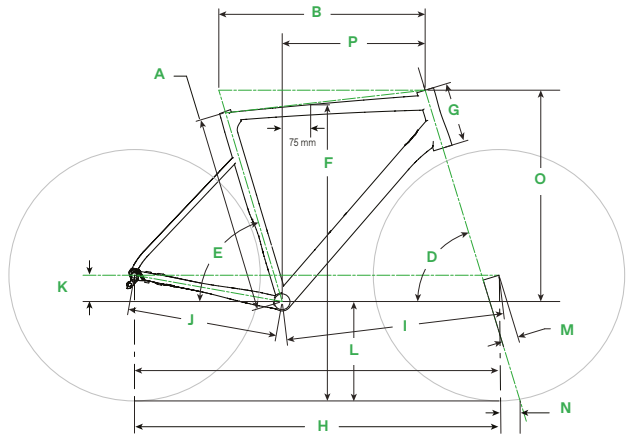

Dimensions = centimeter/inches

Size	44	48	51	54	56	58	60	62
A	40.0/15.7	43.8/17.2	47.7/18.8	51.5/20.3	53.6/21.1	55.8/22.0	57.9/22.8	60.0/23.6
B	51.0/20.1	52.0/20.5	53.0/20.9	54.6/21.5	56.2/22.1	57.8/22.8	59.4/23.4	61.1/24.1
D	70.9°	71.2°	*	*	73.0°	*	*	*
E	74.5°	74.3°	74.1°	73.7°	73.3°	72.9°	72.5°	72.1°
G	9.4/3.7	11.4/4.5	13.0/5.1	15.4/6.0	16.4/6.5	18.8/7.4	20.9/8.2	23.0/9.0
H	97.6/38.4	98.5/38.8	99.4/39.1	100.8/39.7	99.2/39.0	100.5/39.6	101.6/40.0	102.8/40.5
I	58.1/22.9	58.9/23.2	59.8/23.5	61.1/24.0	59.4/23.4	60.7/23.9	61.8/24.3	63.0/24.8
J	40.8/16.1	*	*	*	*	*	*	*
K	7.9/3.1	7.4/2.9	*	7.2/2.8	*	6.9/2.7	*	*
L	26.3/10.4	26.8/10.6	*	27.1/10.6	*	27.3/10.7	*	*
M	5.5/2.2	*	*	*	4.5/1.8	*	*	*
N	6.0/2.4	5.8/2.3	*	*	5.8/2.3	*	*	*
O	50.4/19.8	51.9/20.4	53.4/21.0	55.4/21.8	57.4/22.6	59.4/23.4	61.4/24.2	63.4/25.0
P	37.0/14.6	37.4/14.7	37.8/14.9	38.4/15.1	38.9/15.3	39.5/15.6	40.0/15.8	40.6/16.0

* Indicates same.

All Specifications subject to change without notice.

Serial Number

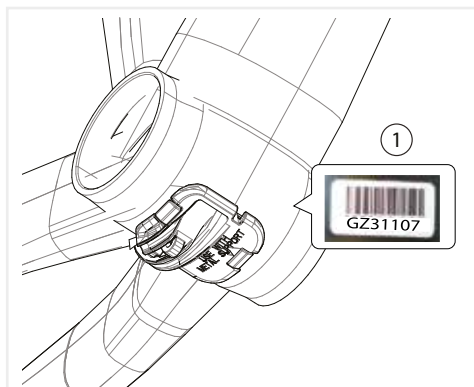

The serial number is located on the bottom bracket. It is a 7-character barcode (1). Use this serial number to register your bike.

To register your bike: go to the **Product Registration** section of our website at www.cannondale.com

Rear Derailleur Mount

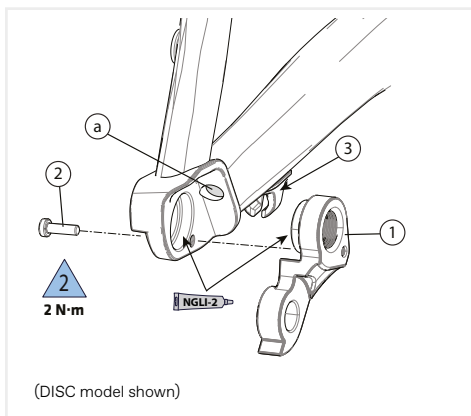

1. RD Hanger
 2. Screw
 3. Removable cable
- stop
a. Di2 wire exit

To replace:

Remove the rear axle.

Remove the mounting screws and remove the old hanger from the dropout. Clean the area around the dropout and inspect the frame carefully for any cracks or damage. If you find damage have the frame inspected by your Cannondale Dealer .

If the dropout is un-damaged, apply a light film of grease between the frame and mount. This will help minimize any noise or “creaking” that might result from very slight movement between the dropout and hanger during movement of the derailleur.

Slide the new hanger onto the dropout. Apply Loctite® 242 (or medium strength thread lock) to the screw threads and tighten to the specified torque.

DT Guides

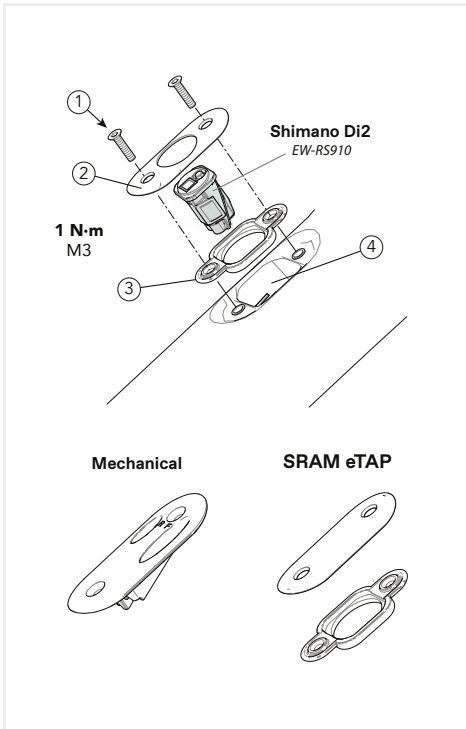

1. Downtube opening
2. Cover
3. Bracket
4. Screws (2X)

Rear Rim Brake Bridge

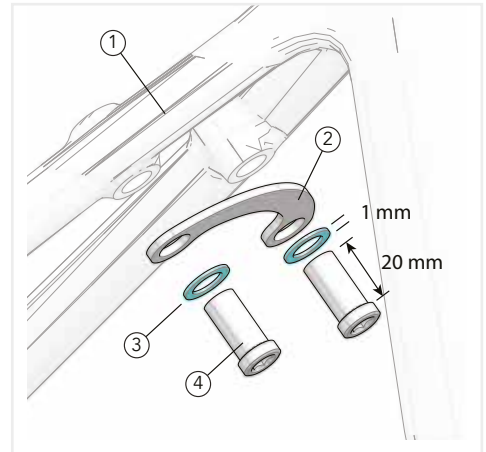

1. Seat Stay
2. Brake Bridge
3. Washer (2X)
4. Bolt (2X)

- The bridge parts are required for rim brake frames. The bridge provides necessary support to the frame and ensures that braking force is not absorbed by movement of the frame.
- Installed on the underside of the seatstays.
- Follow the instruction provided by the brake manufacturer when installing brake.

WARNING

Do not ride without a rear brake system installed. Do not omit or remove the rear brake bridge parts.

Bottom Bracket - BB30A, 73mm

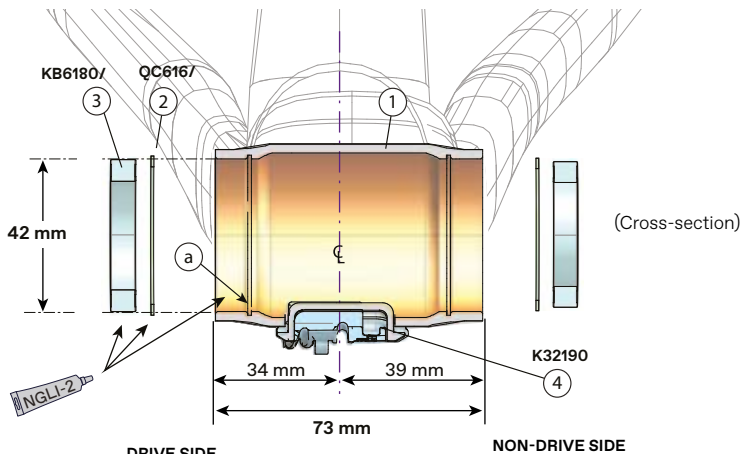

Identification

1. BB30 Shell
2. Circlip (2X)
3. Bearing (2X)
4. Cable guide w/ Support
- a. Circlip Groove

Maintenance

Inspect the bearing condition annually (at a minimum) or anytime the crankset assembly is disassembled, serviced, or if a problem is indicated.

To inspect, when the crankset is removed, rotate the inner bearing race of both bearings; rotation should be smooth and quiet. Excessive play, roughness, or corrosion indicates a damaged bearing.

Removal

To avoid serious damage to the frame, it is important to remove bearing systems very carefully using proper tools indicated by the manufacturer's service instructions. Make sure the bearings (cup or adapter parts) are driven out squarely and evenly from inside the shell! Do not pry components from shell.

Replacement

NOTICE

Consult with your Cannondale Dealer on the quality and compatibility of any proposed replacement component.

Do not use chemical solvents to clean. Do not remove frame material or use surfacing tools on bottom bracket shell.

Frame damage, caused by improper components, component installation or removal is not covered by the limited warranty.

Cable Guide



SIDE VIEW

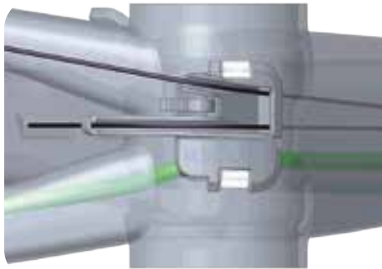
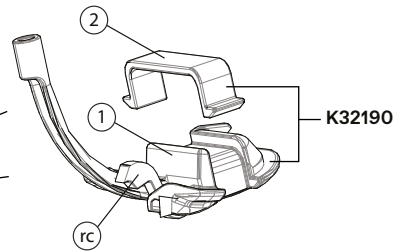

BOTTOM VIEW

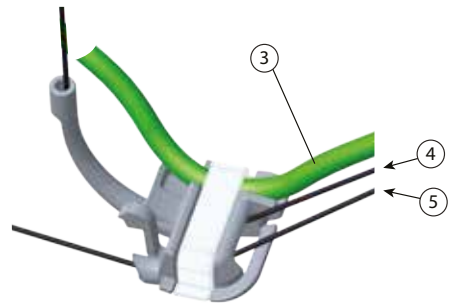

Identification

- | | | |
|------------------|--------------------|---------------------------|
| 1. Guide Body | rc. Retaining Clip | 4. Front Derailleur Cable |
| 2. Guide Support | 3. Rear Brake Hose | 5. Rear Derailleur Cable |

NOTICES

- Both the cable guide body and the metal support must be installed together.** Do not remove the metal support leaving only the cable guide. See following pages for explanation. The inner sleeve of some BB systems, may not be compatible. Consult with you Cannondale Dealer on compatible BB systems.
- All cables, wires, and hoses, must pass through the cable guide.** Otherwise, damage may result from contact with the moving crank system parts.

Bottom Bracket Cable Guide Installation

1. Assemble FD cable first to avoid crossing between FD and RD cable.



2. Afterwards assemble RD cable.

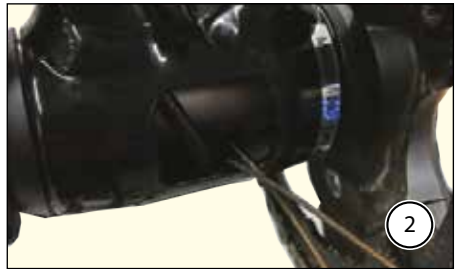

3. Optional: Add cable liner around the location of BB shell.



4. Pull brake hose away from BB spindle.



5. Insert metal strap below brake hose.

Position metal strap approximately in middle of BB window.

Stop pulling brake hose.



6. Route FD and RD cable through window in BB guide

- Avoid cable crossover



7. Put BB guide outside BB window

It may be necessary to push brake hose to NDS so that it rests in its intended position.



8. Use a small flat screwdriver end to push the retaining clip inward until the end of the clip engages the inside the BB shell.



Seat Post

Installation & Adjustment

Before installing:

- Use a clean shop towel to wipe out any residual carbon gel paste from the inside the seat tube.
- Apply fresh carbon friction gel to the seat post and place a little bit inside the seat tube.
- Make sure the seal is in good condition and in place on the seat post.

To adjust:

1. Insert the prepared seat post into the frame.
2. Set the saddle height.
3. Insert 4 mm hex through the underside seat tube opening as shown.
4. Gently, pull the seat post backward (shown below) so the back of the seat post (flat side) surface contacts the flat seat tube and hold while tightening the binder screw to the specified torque.



The seat post and seat tube contact points will mate normally when riding in the occasion this step is missed.

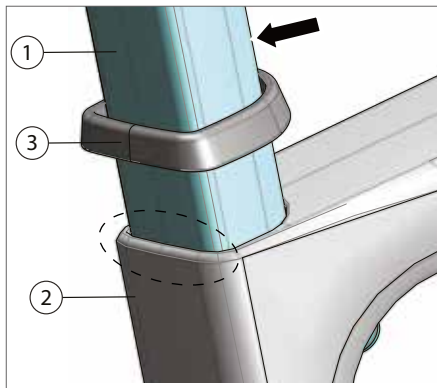

1. Seat post
2. Seat Tube
3. Rubber Grommet

Please Note:

The small gap visible between the seat post and the frame is normal. The rubber grommet is included and may be used to cover this gap.

5. When finished, slide the rubber grommet against the frame.

Maintenance

Periodically, remove the seat post and the clamp assembly to clean, inspect for damage and renew the application of grease and carbon gel.

See also, "Seat Binder Inspection."

Maximum Insert

The total length of seat post that may be inserted will vary with the frame size and should be checked in each frame.

To check, carefully slide a seat post into the frame until it stops; then lift it up 5mm.

NOTICE

A seat post should not be bottomed out inside the frame at any time. Have your Cannondale Dealer size the seat post appropriately.

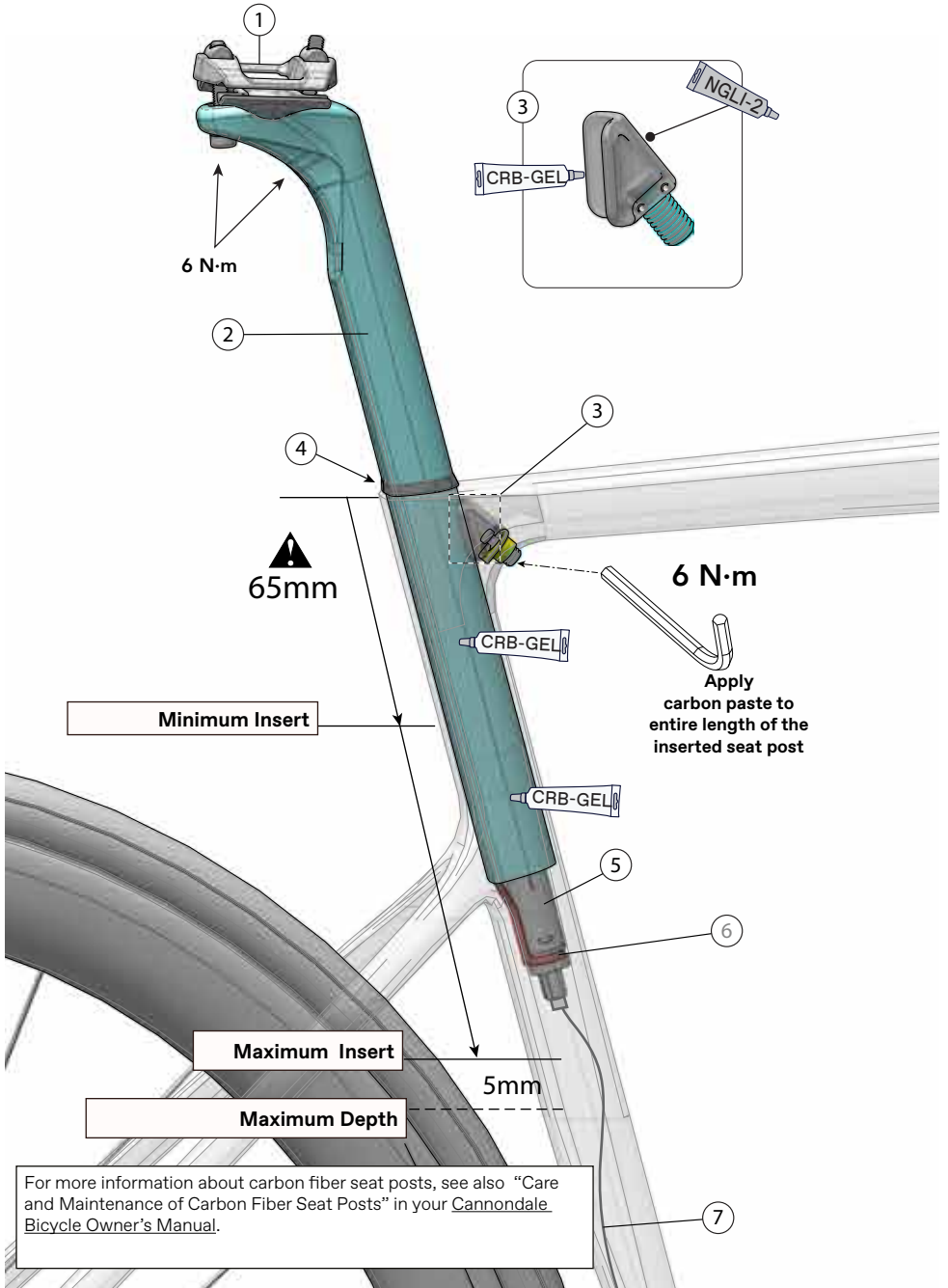

Seat Binder Inspection

The internal seat binder system consists of a sliding clamp assembly and a nut base with double-sided adhesive holding it to a special mating surface inside the seat tube. The sliding clamp parts can be removed when the seat post is out.

Always clean the surfaces of the sliding clamp by wiping them with a clean dry lint-free shop towel only. Do not soak the parts, as the internal washer is lubricated with grease. Solvents will wash out the lubricant and the assembly will have to be regreased by disassembling it completely.

NOTICE

If the nut base has become rotated, it should be removed and re-affixed to the frame. The process is described in the Service Instruction for the parts kit. These instruction are not provided in this manual. We recommend that you have a Cannondale Dealer perform the replacement.

Please Note: During first assembly of the nut base, it is important to not push on the 4mm allen when tightening onto the seatpost. This can disengage the adhesive tape before proper bonding. A poor bond can lead to misalignment. The 3M™ VHB™ Tape 5980 is pressure sensitive.

To inspect

1. To remove the seat post. See previous page.
2. To remove the sliding clamp, use a 4 mm hex key and turn grub screw slowly clockwise until the clamp is disengaged from the nut base.
3. Use the 4 mm hex to push the clamp out through the seat tube opening.
4. Look into the frame opening. Use a pen flashlight. Check the position of the nut base. See CORRECT next page.
5. If the nut base is missing, or rotated or damaged, a replacement is required. This service should be performed by a Cannondale Dealer.
6. Check the condition of the clamp. The seat post face and frame contact surfaces should be smooth. If they are not, the clamp assembly should be replaced with a new one.
7. Clean the parts and inside the seat tube with a dry shop towel and re-apply grease and carbon paste as indicated.
8. Returning the sliding clamp to the frame, using the 4 mm hex to guide it to the nut base.
9. Turn the grub screw counter-clockwise to engage the nut base. Make sure it is engaged sufficiently to easily insert the seat post into the seat tube.

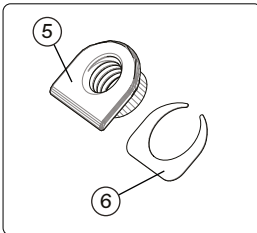
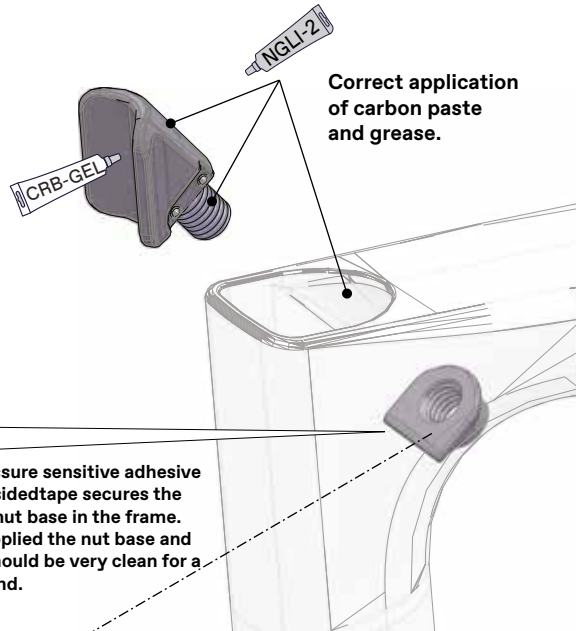
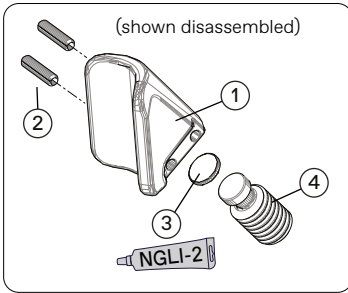

The pressure sensitive adhesive double-sided tape secures the aligned nut base in the frame. When applied the nut base and frame should be very clean for a good bond.

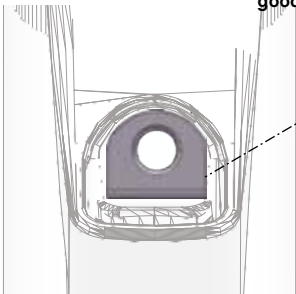

This is CORRECT.

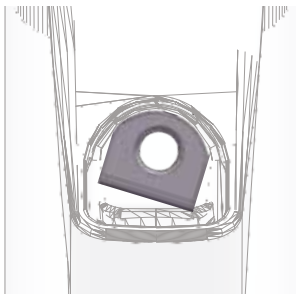

**This is INCORRECT.
The nut plate is rotated.**

Ready to accept seat post.

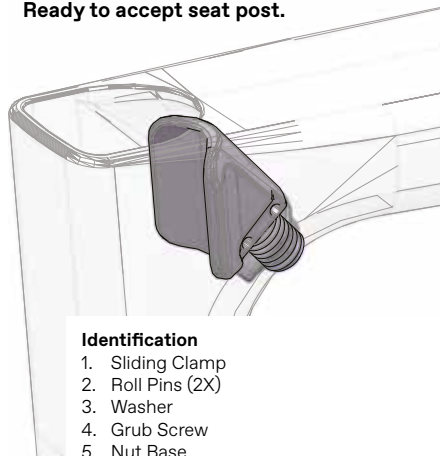

Identification

1. Sliding Clamp
2. Roll Pins (2X)
3. Washer
4. Grub Screw
5. Nut Base
6. Pressure Sensitive Adhesive Tape (Double-sided)

REPLACEMENT PARTS

Frame / Fork

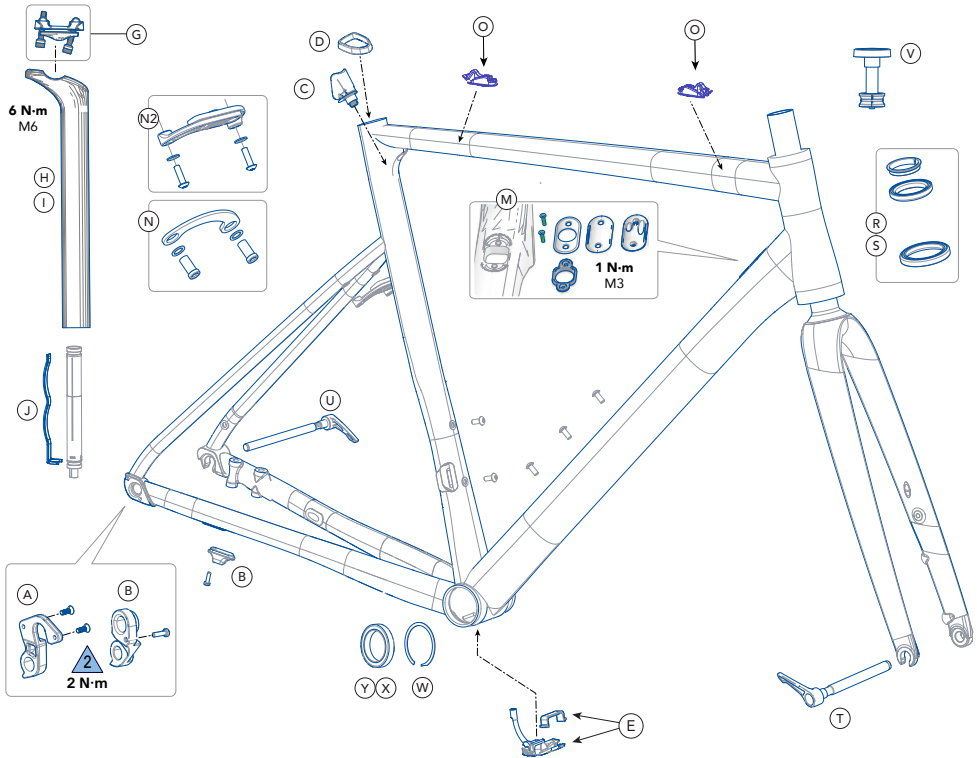

ID	Part Number	Description	DISC	RIM
A	KP255/	Derailleur Hanger QR ST SS 027		✓
B	K33009	Derailleur Hanger TA ST SS 070	✓	
C	K26060	CAAD13 Internal Seat Binder	✓	✓
D	K26070	Seatpost Silicone Grommet	✓	✓
--	KF115/	Carbon Seatpost Gel	✓	✓
G	K26050	KNOT 27 Rail Clamps and Hardware	✓	✓

ID	Part Number	Description	DISC	RIM
H	K2601000	HG 27 KNOT Crb Seatpost 330mm 0 O/Set	✓	✓
	K2601015	HG 27 KNOT Crb Seatpost 330mm 15 O/Set	✓	✓
I	K2602015	C1 27 KNOT Alloy Seatpost 330mm 15 O/Set	✓	✓
J	K32180	KNOT 27 Di2 Battery Mount	✓	✓
M	K32160	S6 EVO/CAAD13 Down Tube Cable Guide	✓	✓
N	K31000	Rim Brake Bridge		✓
N2	CK1168U100S	Adjustable Fender Bridge BLK	✓	
O	K32010	Clip-in Brake Cable Stop QTY 2		✓
R	K35028	1 1/4 Crb Headset No Crown Race	✓	✓
S	K35038	1 3/8 Crb Headset No Crown Race	✓	✓
T	K83019	Speed Release TA 100×12 2Lead P1.0 119mm	✓	
U	K83029	Speed Release TA 142×12 2Lead P1.0 165mm	✓	
V	K35059	SL Compression Plug with Top Cap	✓	✓
	K32190	CAAD13 BB Cable Guide	✓	✓
W	QC616/	BB Si Circlips (QTY 2)	✓	✓
Y	KB6180/	BB30 Bearing Blue (QTY 2)	✓	✓
X	K22037	BB30 Bearing Blue (QTY 24)	✓	✓

Adjustable Fender Bridge - DISC BRAKE

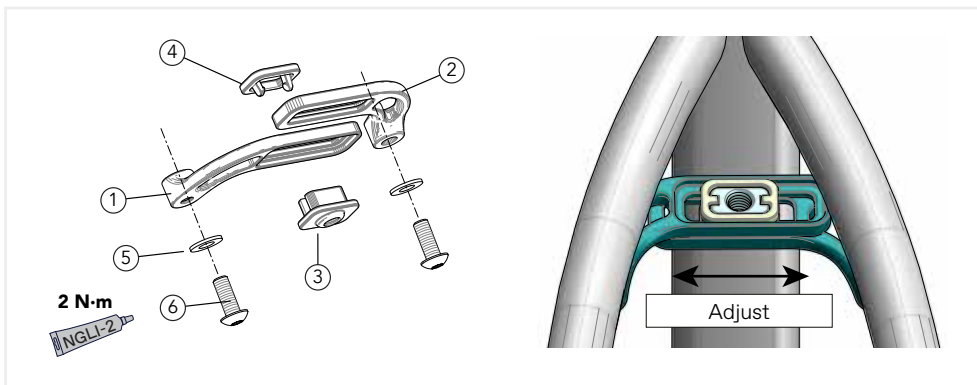

Identification

- | | | |
|--------------------|---------------|----------------|
| 1. Right Mount Arm | 3. Nut | 5. Washer (2X) |
| 2. Left Mount Arm | 4. Slide Ring | 6. Screw (2X) |

Flat Mount Bolt Length - DISC BRAKE

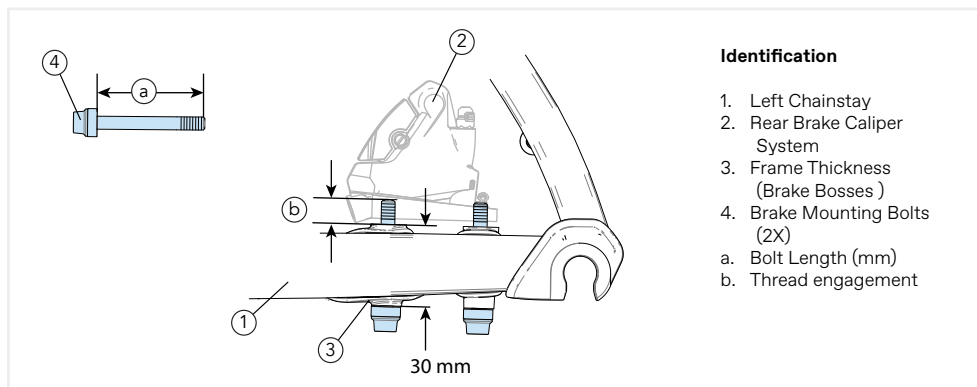

Identification

1. Left Chainstay
2. Rear Brake Caliper System
3. Frame Thickness (Brake Bosses)
4. Brake Mounting Bolts (2X)
- a. Bolt Length (mm)
- b. Thread engagement

WARNING

The correct bolts ensure proper thread engagement with the brake system parts (e.g., caliper, adapters (if present)). Your bike has been assembled with the correct bolts for the brake system. If you change the original equipment brakes on your bike, or are building a frameset, be sure to use brake bolts lengths to achieve the thread engagement as specified by the brake system manufacturer. Consult your Cannondale Dealer for help.

The wrong bolt length (engagement) can allow the brakes to disengage from the bicycle, which can lead to a crash, which can lead to serious injury, paralysis, or death of the rider.

WWW.CANNONDALE.COM

© 2019 Cycling Sports Group
CAAD13 Owner's Manual Supplement
137370 Rev. 1

CANNONDALE USA

Cycling Sports Group, Inc.
1 Cannondale Way,
Wilton CT, 06897, USA
1-800-726-BIKE (2453)
www.cannondale.com

CANNONDALE EUROPE

Cycling Sports Group Europe, B.V.
Mail: Postbus 5100
Visits: Hanzepoort 27
7575 DB, Oldenzaal Netherlands

CANNONDALE UK

Cycling Sports Group
Vantage Way, The Fulcrum,
Poole, Dorset, BH12 4NU
+44 (0)1202732288
sales@cyclingsportsgroup.co.uk