

# TOPSTONE

## Owner's Manual Supplement



### **WARNING**

READ THIS SUPPLEMENT AND YOUR  
CANNONDALE BICYCLE OWNER'S MANUAL.  
Both contain important safety information. Keep  
both for future reference.

## Safety Messages

In this supplement, particularly important information is presented in the following ways:



### **WARNING**

Indicates a hazardous situation which, if not avoided, may result in death or serious injury.

### **NOTICE**

Indicates special precautions that must be taken to avoid damage.

The following symbols are used in this manual:

Symbol	Name	Description
	NGLI-2 synthetic grease	Apply NGLI-2 synthetic grease.
	Carbon gel	Apply carbon gel (friction paste) KF115/
	Medium-strength removable thread lock	Apply Loctite® 242 (blue) or equivalent.

## Cannondale Supplements

This manual is a “supplement” to your [Cannondale Bicycle Owner’s Manual](#).

This supplement provides additional and important model specific safety, maintenance, and technical information. It may be one of several important manuals/supplements for your bike; obtain and read all of them.

Please contact your Authorized Cannondale Dealer immediately if you need a manual or supplement, or have a question about your bike. You may also contact us using the appropriate country/region/location information.

You can download Adobe Acrobat PDF versions of any manual/supplement from our website: <http://www.cannondale.com>.

## Contacting Cannondale

### Cannondale USA

Cycling Sports Group, Inc.  
1 Cannondale Way, Wilton CT, 06897, USA  
1-800-726-BIKE (2453)

### Cycling Sports Group Europe B.V

Mail: Postbus 5100  
Visits: Hanzepoort 27  
7570 GC, OLDEENZAAL, Netherlands  
Tel: +41 61 551 14 80  
Fax: +31 54 151 42 40

### International Distributors

Consult our website to identify the appropriate Cannondale Dealer for your region.

## CONTENTS

<b>Safety Information .....</b>	<b>2-5</b>
<b>Technical Information .....</b>	<b>6-19</b>
<b>Replacement Parts.....</b>	<b>20</b>

## Your Cannondale Dealer

To make sure your bike is serviced and maintained correctly, and that you protect applicable warranties, please coordinate all service and maintenance through your Authorized Cannondale Dealer.

### NOTICE

Unauthorized service, maintenance, or repair parts can result in serious damage and void your warranty.

## SAFETY INFORMATION

### Important Composites Message

#### WARNING

Your bike (frame and components) is made from composite materials also known as “carbon fiber.”

All riders must understand a fundamental reality of composites. Composite materials constructed of carbon fibers are strong and light, but when crashed or overloaded, carbon fibers do not bend, they break.

For your safety, as you own and use the bike, you must follow proper service, maintenance, and inspection of all the composites (frame, stem, fork, handlebar, seat post, etc.) Ask your Cannondale Dealer for help.

We urge you to read PART II, Section D. “Inspect For Safety” in your [Cannondale Bicycle Owner's Manual](#) BEFORE you ride.

**You can be severely injured, paralyzed or killed in an accident if you ignore this warning.**

### Inspection & Crash Damage Of Carbon Frames/Forks

#### WARNING

#### **After A Crash Or Impact:**

Inspect frame carefully for damage. See PART II, Section D. Inspect For Safety in your [Cannondale Bicycle Owner's Manual](#).

Do not ride your bike if you see any sign of damage, such as broken, splintered, or delaminated carbon fiber.

#### **Any of the following may indicate a delamination or damage:**

- An unusual or strange feel to the frame
- Carbon which has a soft feel or altered shape
- ·Creaking or other unexplained noises,
- Visible cracks, a white or milky color present in carbon fiber section

**Continuing to ride a damaged frame increases the chances of frame failure, with the possibility of injury or death of the rider.**

## Intended Use



The intended use of all models is  
ASTM CONDITION 2,  
General Purpose Riding.

### WARNING

Please read your [Cannondale Bicycle Owner's Manual](#) for more information about Intended Use and Conditions 1-5.

## Servicing

### WARNING

**This supplement may include procedures beyond the scope of general mechanical aptitude.**

Special tools, skills, and knowledge may be required. Improper mechanical work increases the risk of an accident. Any bicycle accident has risk of serious injury, paralysis or death.

**To minimize risk we strongly recommend that owners always have mechanical work done by an Authorized Cannondale Dealer.**

## Disc Brakes on Road Bikes

### WARNING

Relative to conventional rim brakes, disc brakes are less affected by water, do not wear or heat the rims and therefore are more consistent. Disc brakes also may be more powerful.

**To minimize risk of injury or accidents:**

- Understand that road bikes have a relatively small tire contact patch (part of the tire that touches the road). In order to apply the brakes safely and effectively, you may need more or less braking force in different situations. You need to take into account various road and weather conditions that can affect traction.
- Disc brakes are excellent, but not some kind of magic. Take some time riding your new disc brake road bike in lower risk circumstances to get used to the feel and performance of the disc brakes and tires.

**You can be severely injured, paralyzed or killed in an accident if you ignore this message.**

## Trainers

If you ride a trainer that requires removal of the front wheel and clamps the fork dropouts: Be sure your fork quick release is tight! Relative movement will wear parts, weaken and damage your bike.

If you ride a trainer that holds the bike up by clamping the rear quick release between two cones: Take off the lightweight quick release that came with your bike. Substitute a heavy, classic all steel quick release and clamp it tight! Relative movement will wear parts, weaken and damage your bike. Note that many modern quick releases will not fit the clamping cones in this kind of trainer because their shapes are incompatible.

For thru axles, make sure you follow the trainer manufacturer instructions for the use of any required adapters.

Be particularly cautious with a carbon frame or fork. Carbon is relatively soft, not abrasion resistant. If there is any relative movement, carbon will wear quickly.

If you ride a trainer a lot, consider using an old bike: Corrosion from sweat will take its toll. Weight is irrelevant. Save wear on your expensive components.

Ask your dealer for help with trainers, the right one and the correct way to use it.

### NOTICE

**TRAINERS - Improperly mounting a bike in a trainer, or using one that is not compatible with your particular bike frame can cause serious damage.**

**WATER BOTTLES - An impact, crash, or loose bottle cage can result in damage to your frame.**

This kind of damage is not covered by the Cannondale Limited Warranty.

## Water Bottles

Side impacts to a water bottle or cage can result in damage to threaded inserts due to the leverage on a very small area. In a crash, certainly the last thing you should be worried about is saving the threaded inserts in your frame. However, when you are storing or transporting your bike, take steps to prevent situations where a water bottle may be hit or bumped by a strong force that would cause damage. Remove bottle and cage when you are packing your bike for travel.

Periodically check the attachment of the bottle cage; tighten the cage bolts if necessary. Don't ride with a loose bottle cage. Riding with loose cage bolts can produce a rocking motion or vibration of the attached cage. A loose cage will damage the insert and possibly lead to the inserts to pull out.

It may be possible to repair a loose insert, or install another insert only if the frame is undamaged. Replacement requires the use of a special tool. If you notice damage to the threaded insert, please ask your Cannondale Dealer for help.

## Building Up A Frame Set

Before building up a frame set, consult with your Cannondale Dealer and the component manufacturers, and discuss your riding style, ability, weight, and interest in and patience for maintenance.

Make sure the components chosen are compatible with your bike and intended for your weight and riding style.

Generally speaking, lighter weight components have shorter lives. In selecting lightweight components, you are making a trade-off, favoring the higher performance that comes with less weight over longevity. If you choose more lightweight components, you must inspect them more frequently. If you are a heavier rider or have a rough, abusive or "go for it" riding style, buy heavy duty components.

Read and follow the component manufacturers warnings and instructions.

## Tightening Torques

Correct tightening torque for the fasteners (bolts, screws, nuts) on your bicycle is very important to your safety. Correct tightening torque for the fasteners is also important for the durability and performance of your bicycle. We urge you to have your dealer correctly torque all fasteners using a torque wrench. If you decide to torque fasteners yourself always use a torque wrench.

### Find Tightening Torque Information :

The wide range of bicycle models and components used means that a listing of tightening torque would be out of date by the time it was published. Many fasteners should be installed with a thread locking adhesive such as Loctite®.

#### **To determine correct tightening torque and any adhesive application for a fastener we ask you to check:**

- Many components are marked. On-product marking is becoming common.
- Torque specs in the component manufacturers instructions shipped with your bicycle.
- Torque specs listed on the websites of component manufacturers.
- With your dealer. Dealers have access to current data and have experience with correct torque for most fasteners.

## TECHNICAL INFORMATION

### Frame Specification

Item	Specification
Head Tube	UPR: 1-1/8 in, LWR: 1-1/4 in
Headset	Integrated, 1-1/8 in - 1-1/4 in
Bottom Bracket: Type / Width	BB30A / 83 mm
Front Derailleur	Brazed-on
Seat Post: Dia./Binder	27.2 mm / Internal Wedge
▲ Min. Seat Post Insert	65 mm
▲ Max. Seat Post Insert	XS: 140 mm, S-XL: 188 mm , See page 13.
▲ Tire Size x Max. Width	700c x 40 mm (measured), 650b x 48 mm (measured)
Brakes: Mount Type/Min/Max Rotor Dia.	RR: Flat Mount / 140 mm / 160 mm FT: Flat Mount +20mm / 160 mm / 180 mm
Axles: Type/Length	RR: Speed Release, Double Lead / 142 × 12 mm, 165 mm Length FT: Speed Release, Double Lead / 100 × 12 mm, 119 mm Length
Ai Offset	Rear Wheel: 3mm Offset to NDS HollowGram SpideRing: Ai Offset
▲ Intended Use:	ASTM Condition 2
▲ Max. Weight Limit: Total	305 lbs / 138 kg



## Geometry

- A Seat Tube Length
- B Top Tube Horizontal
- D Head Tube Angle
- E Seat Tube Angle (effective)
- F Standover
- G Head Tube Length
- H Wheelbase
- I Front Center
- J Chain Stay Length
- K Bottom Bracket Drop
- L Bottom Bracket Height
- M Fork Rake
- N Trail
- O Stack
- P Reach

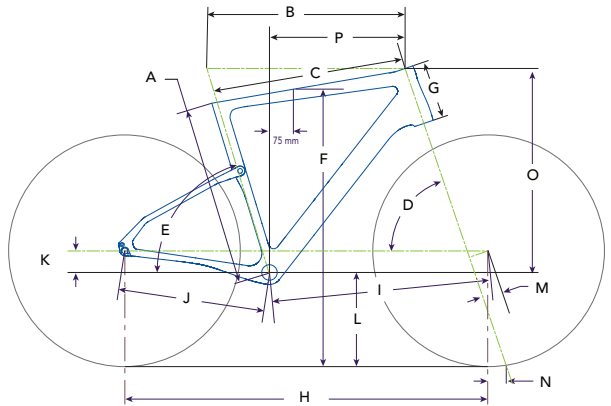

Dimensions = centimeter/inches

Size	XS	S	M	L	XL
A	41.0/16.1	45.8/18.0	50.5/19.9	55.3/21.8	60.0/23.6
B	52.5/20.7	54.4/21.4	56.1/22.1	57.9/22.8	59.6/23.5
D	70.0°	71.2°	*	*	*
E	73.1°	*	*	*	*
F	71.5/28.1	76.1/30.0	80.3/31.6	84.3/33.2	88.5/34.8
G	9.7/3.8	13.1/5.2	16.5/6.5	19.8/7.8	23.2/9.1
H	99.9/39.3	101.0/39.8	103.0/40.6	104.9/41.3	106.8/42.1
I	59.4/23.4	60.4/23.8	62.3/24.5	64.2/25.3	66.0/26.0
J	41.5/16.3	*	*	*	*
K	6.9/2.7	6.4/2.5	6.1/2.4	*	5.9/2.3
L	27.3/10.7	27.8/10.9	28.1/11.1	*	28.3/11.1
M	5.5/2.2	*	*	*	*
N	6.6/2.6	5.8/2.3	*	*	*
O	51.8/20.4	55.0/21.6	57.9/22.8	61.0/24.0	64.1/25.2
P	36.8/14.5	37.7/14.8	38.5/15.2	39.4/15.5	40.1/15.8

\* Indicates same.

All Specifications subject to change without notice.

## Rear Derailleur Mount

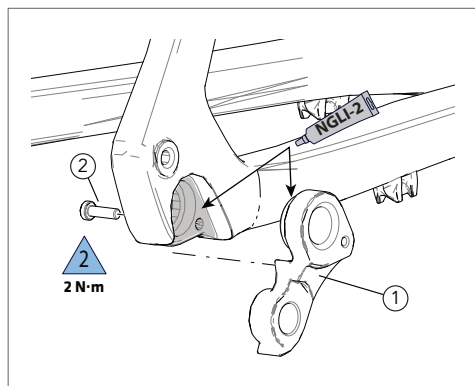

1. RD Mount
2. Screw

### To replace:

Remove the rear axle.

Remove the mounting screw(s) and remove the old hanger from the dropout. Clean the area around the dropout and inspect the frame carefully for any cracks or damage. If you find damage have the frame inspected by your Cannondale Dealer .

If the dropout is un-damaged, apply a light film of grease between the frame and mount. This will help minimize any noise or "creaking" that might result from very slight movement between the dropout and hanger during movement of the derailleur.

Slide the new hanger onto the dropout. Apply Loctite® 242 (or medium strength thread lock) to the screw threads and tighten to the specified torque.

## Front Derailleur Mount

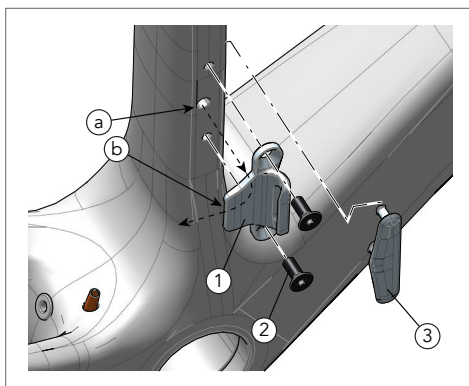

1. FD Mount
  2. Screws (2X)
  3. Cover
- a. Di2 Frame exit  
b. Di2 Mount exit

## Serial Number

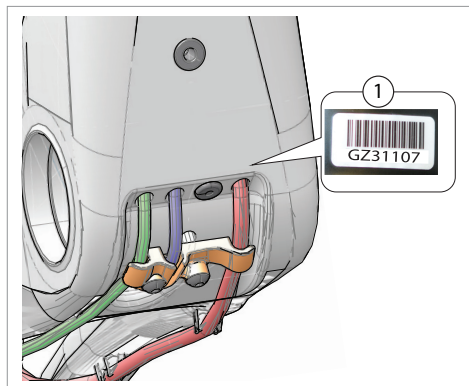

The serial number is located on the bottom bracket. It is a 7-character barcode (1). Use this serial number to register your bike.

To register your bike: go to the **Product Registration** section of our website at [www.cannondale.com](http://www.cannondale.com)

## Bottom Bracket Cable Guide

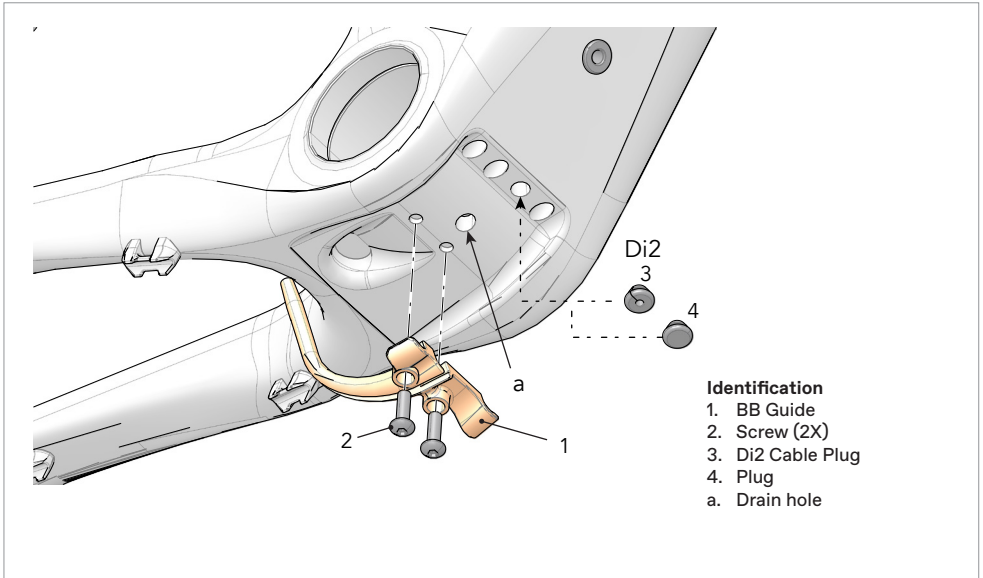

## Rear Fender Support

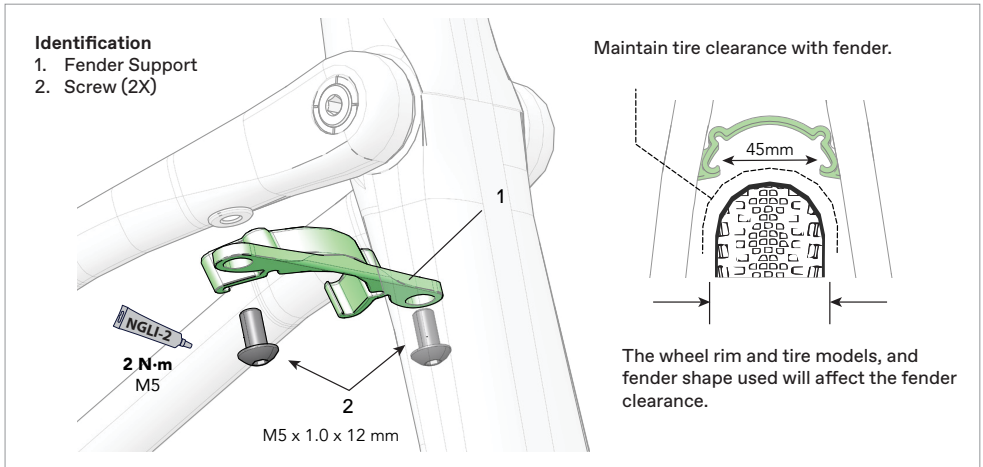

Please Note: (1) Check tire clearance with the tire fully inflated. (2) Mounting a tire with a smaller profile, one smaller than the maximum tire size for the frame, or currently on the wheel may be required to fit a compatible fender. (3) Any fender must be secured by the support and should not be loose. (4) Do not modify any parts or the frame in order to install a fender.

## Bottom Bracket - BB30A / 83 mm

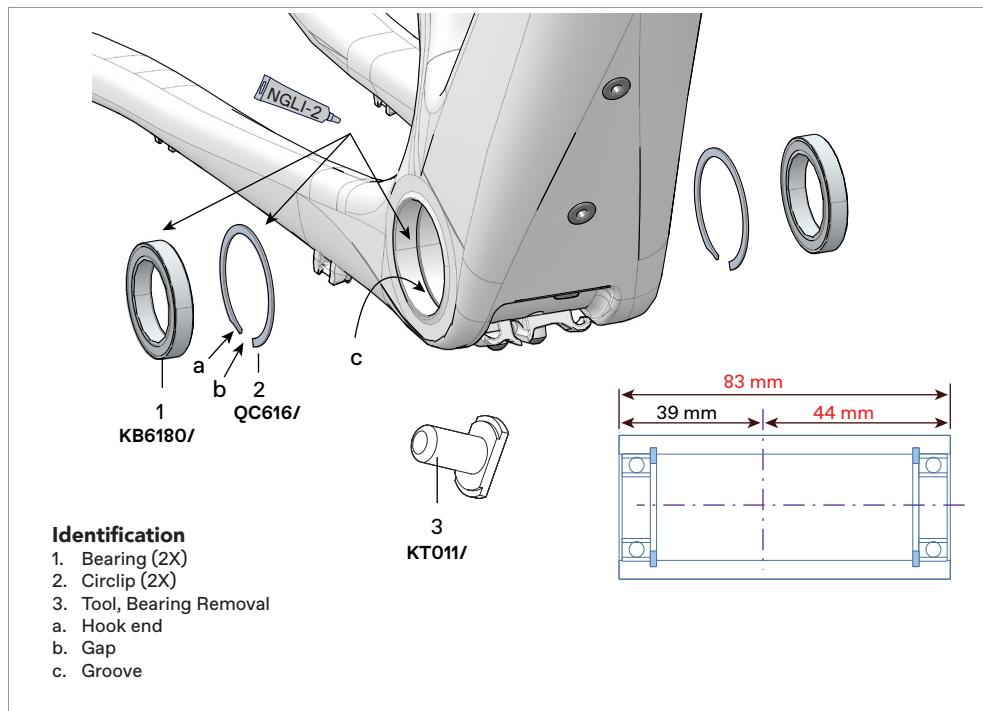

### Maintenance

In general, you should inspect the condition of the bearings annually (at a minimum) or anytime the crankset assembly is disassembled, serviced, or if a problem is indicated.

To inspect, when the crankset is removed, rotate the inner bearing race of both bearings; rotation should be smooth and quiet. Excessive play, roughness, or corrosion indicates a damaged bearing.

### Removal

To avoid serious damage to the frame, it is important to remove bearing systems very carefully using proper tools indicated by the manufacturer's service instructions. Make sure the bearings (cup or adapter parts) are driven out squarely and evenly from inside the shell! Do not pry components from shell.

### Replacement

#### NOTICE

Consult with your Cannondale Dealer on the quality and compatibility of any proposed replacement component.

Do not use chemical solvents to clean. Do not remove frame material or use surfacing tools on bottom bracket shell.

Frame damage, caused by improper components, component installation or removal is not covered by the limited warranty.

## Routing

### Identification

FD - Front Derailleur  
RD - Rear Derailleur  
RB - Rear Brake  
SP - Seat post Battery  
Di2 - Plug

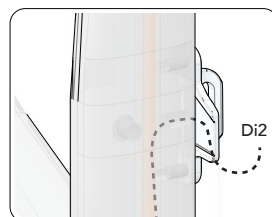
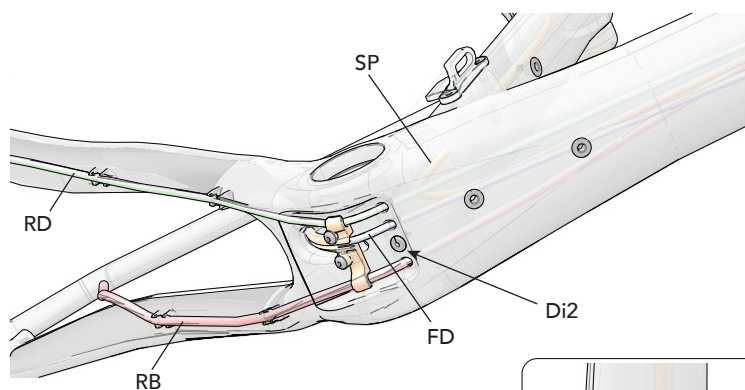
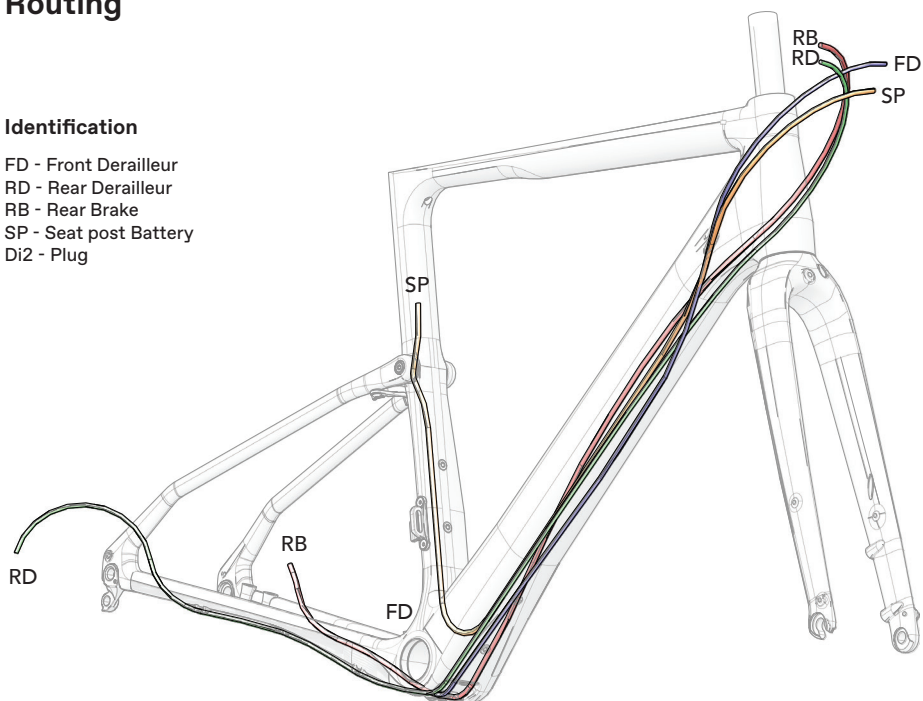

## LockR

### To remove the LockR from the frame:

1. Loosen the screw 4-6 turns using a T25 Torx key.
2. Tap head of screw with a rubber mallet to un-seat the wedge bolt located on the opposite side.
3. Remove the screw and wedge bolt from the still-installed axle.
4. If the wedge did not come out with the screw, insert a 5 mm hex key and turn to free and remove it. If wedge still sticks insert a wooden or plastic dowel into the drive side and drive it out.
5. To remove the axle itself, insert a 6 mm hex key into the axle on the non-drive side and turn counter-clockwise until it can be removed.

### To install the LockR on the frame:

1. Disassemble and clean all parts of the LockR axle. Do not install it assembled.  
Inspect the parts for damage (burrs, scratches, deformity, wear). Replace the entire LockR assembly if any damage is found.
2. Apply a light coating of a high-quality bicycle bearing grease to all parts.
3. Align the linkage and bearing and insert the threaded end of the pivot axle (1) in from the non-drive side.
4. Tighten the inserted pivot axle to 1 Nm using a 6 mm hex key fitted torque wrench from the non-drive side.
5. Insert the wedge bolt (2) into the drive side of the axle and insert the small end of the wedge (3) into the non-drive side axle head.
6. Thread the screw (4) into wedge bolt with a wrench and tighten to 5.0 Nm.

### NOTICE

Use a calibrated torque wrench. Exceeding 1 N·m will result in permanent damage to the LockR pivot system.

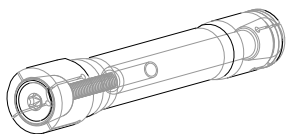

- Do not install assembled.
- Apply grease to all parts.

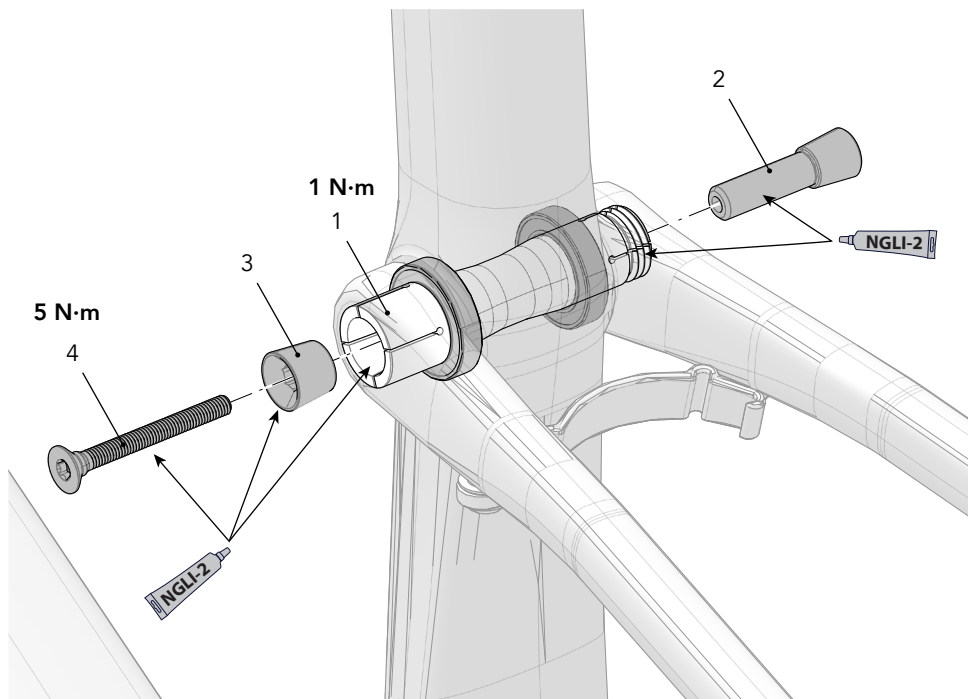

Unthread &  
tap mallet

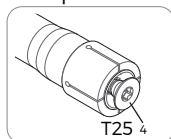

dislodge &  
remove

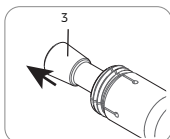

Insert 5mm &  
turn to free

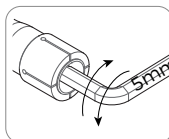

Remove

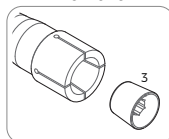

Unthread  
Remove

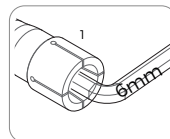

## Seat Tube / Seat Stay Pivot Bearings

### REMOVE

1. Remove LockR pivot hardware.
2. Insert remove plate (4) through ST pivot so it's small OD cylindrical surface engages the inside of the bearing.
3. Insert M5X30mm screw (7) through hole in remove plate (4) so threads are pointing out through SS pivot end.
4. Thread tool handle (3) onto M6X30mm screw (7) only 2-3 turns.
5. Pull SS end away from ST just enough to allow remove cup (5) to be snapped over M6X30mm screw (7).
6. Hold M6X30mm screw (7) stationary with 5mm hex key while turning tool handle (3) until bearing is fully pulled out of pivot and into remove cup.
7. Unthread tool handle to remove tool from the frame.
8. Repeat for the other side.

### INSTALL

1. Pull drive side SS end away from ST just enough to slip larger OD side of install plate (2) into ST pivot bore.
2. Place new bearing on smaller OD side of 2nd install plate (2).
3. Apply grease to non-drive side ST pivot bore.
4. Pull non-drive side SS end away from ST just enough to slip 2nd install plate (2) and bearing into position.
5. Insert M6X70mm screw (6) through both install plates so it's threaded end protrudes through SS end on non-drive side.
6. Thread tool handle (3) onto M6X70mm screw (6) and tighten while holding screw stationary with 5mm hex key. Tighten until bearing is fully pressed into ST pivot bore.
7. Remove Tool handle (3), M6X70 screw (6) and drive side install plate (2).
8. Place new bearing on smaller OD side of install plate (2).
9. Apply grease to drive side ST pivot bore
10. Pull drive side SS end away from ST just enough to slip install plate (2) and bearing into position.
11. Insert M6X70mm screw (6) through both install plates so it's threaded end protrudes through SS end on drive side.
12. Thread tool handle (3) onto M6X70mm screw (6) and tighten while holding screw stationary with 5mm hex key. Tighten until bearing is fully pressed into ST pivot bore.
13. Unthread tool handle (3) and remove all tools from pivot.
14. Continue with LockR axle installation procedure.

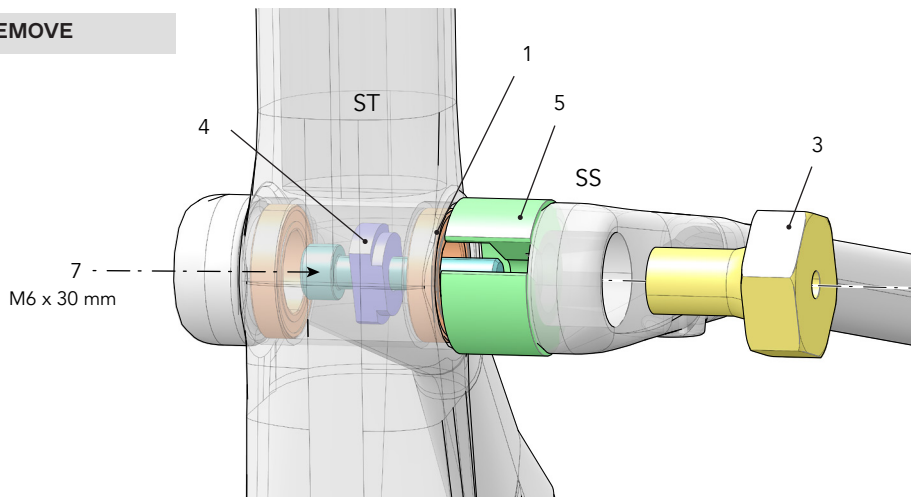
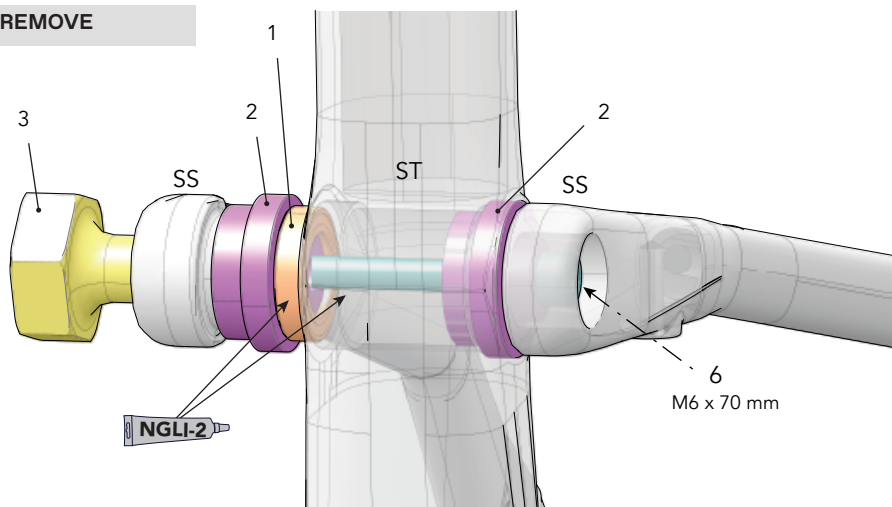

**REMOVE****REMOVE****Identification**

1. Bearing
2. Install Plate
3. Tool Handle
4. Remove Plate

5. Remove Cup
6. Screw M6 x 70mm
7. Screw M6 x 30 mm
- SS Seat Tube

ST Seat Stay (end)

## Seat Binder

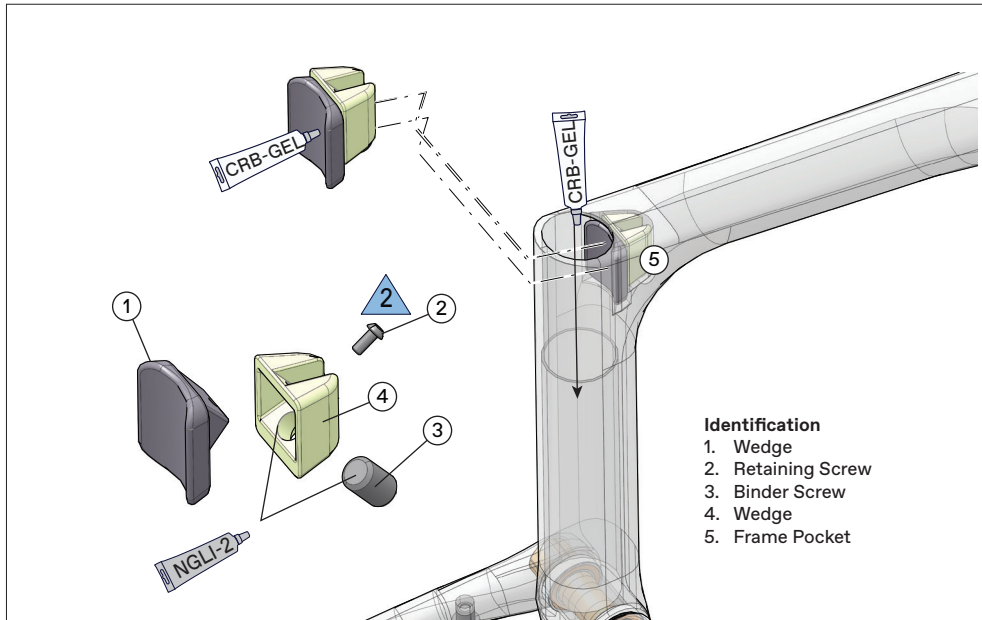

Periodically, to maintain the seat binder assembly, it is recommended to:

1. Remove the seat post.
2. Use a 4mm hex key and your finger to the binder assembly from the frame pocket (5).
3. Disassemble the binder parts. Clean the binder parts to remove any old grease and carbon gel/friction paste. Use only acetone or isopropyl alcohol and a clean shop towel.
4. Apply light grease only to the wedge (1) surface shown above. **Don't grease the wedge surface that faces the seat post.** Reassemble the wedges. Apply Loctite® 242 to the retaining screw (2) threads. Tighten the retaining screw lightly, then back it off one half of a turn so that the wedge parts slide freely.
5. Apply grease to the binder screw (3) and thread 2-3 turns into the wedge (4).
6. Clean the frame pocket and the inside of the seat tube. Use acetone or isopropyl alcohol. Wipe with a dry shop towel. Insert the binder assembly into the frame pocket.
7. Use a 4mm hex key and your finger and return the assembly into the frame pocket.
8. Install the seat post.

### **WARNING**

Wear safety glasses and hand protection when performing any work. Acetone and isopropyl alcohol are flammable liquids. Handle carefully. Wipe up chemical spills immediately.

## Seat Post

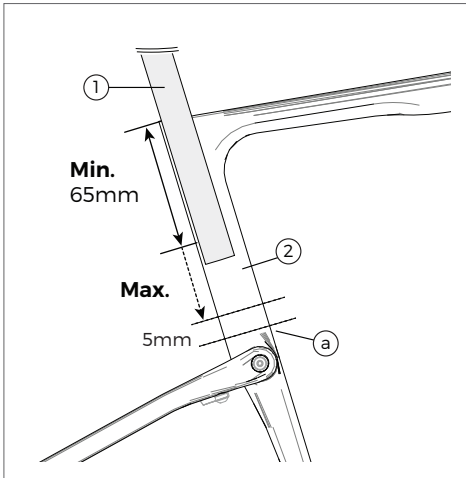

1. Seat Post                      a. Bottom Out limit  
2. Seat Binder

### Minimum Insert

The minimum insert depth the seat post must be inserted into the frame is 65mm.

### Maximum Insert

The total length of seat post that may be inserted will vary with the frame size and should be checked in each frame.

Frame Size (cm)	Maximum Insert (mm)
XS	140
S - XL	188

### NOTICE

Use the correct seat post length shown above. Do not force or bottom-out the seat post inside the frame.

### Removal

To remove the seat post, insert a 4mm hex key into the frame opening under the seat tube top tube junction. Turn the wedge bolt counter-clockwise to loosen it. When bolt is loose simply lift the seat post up out of the seat tube. Then use the hex key and your finger to guide the seat binder of the frame socket.

### Installation

Before inserting the seat post into the frame, use a clean shop towel to wipe out any residual carbon gel paste from the inside the seat tube. Do not use any spray cleaners or solvents.

Apply fresh carbon friction gel to the seat post and place a little bit inside the seat tube. See also "Seat Binder."

Clean the wedge assembly and lightly grease the parts. Apply Loctite (242 (blue)) to the small assembly screw, assemble, tighten finger tight and back off 1/2 turn so the wedge parts move freely. Insert the loosened assembly into the frame, then carefully insert the seat post into the frame.

Set the saddle height, and tighten the clamp bolt to the specified torque with a torque wrench.

### Maintenance

Periodically, remove the seat post and the clamp assembly to clean, inspect for damage and renew the application of grease and/or carbon gel.

For more information about carbon fiber seat posts, see also "Care and Maintenance of Carbon Fiber Seat Posts" in your [Cannondale Bicycle Owner's Manual](#).

## Sizing a seat post

If the seat post must be cut, use the appropriate saw blade for the seat post material, aluminum or carbon. Lightly sand the edges of the cut seat tube with light sandpaper. Re-mark the minimum insert line on the post.

**Be sure to remove any installed battery before cutting a seat post.**



### **WARNING**

**The seat post must only be cut by a professional bike mechanic.** Incorrectly cutting the seat post can result in damage leading to an accident.

## Water Bottle / Fender Mount Fasteners

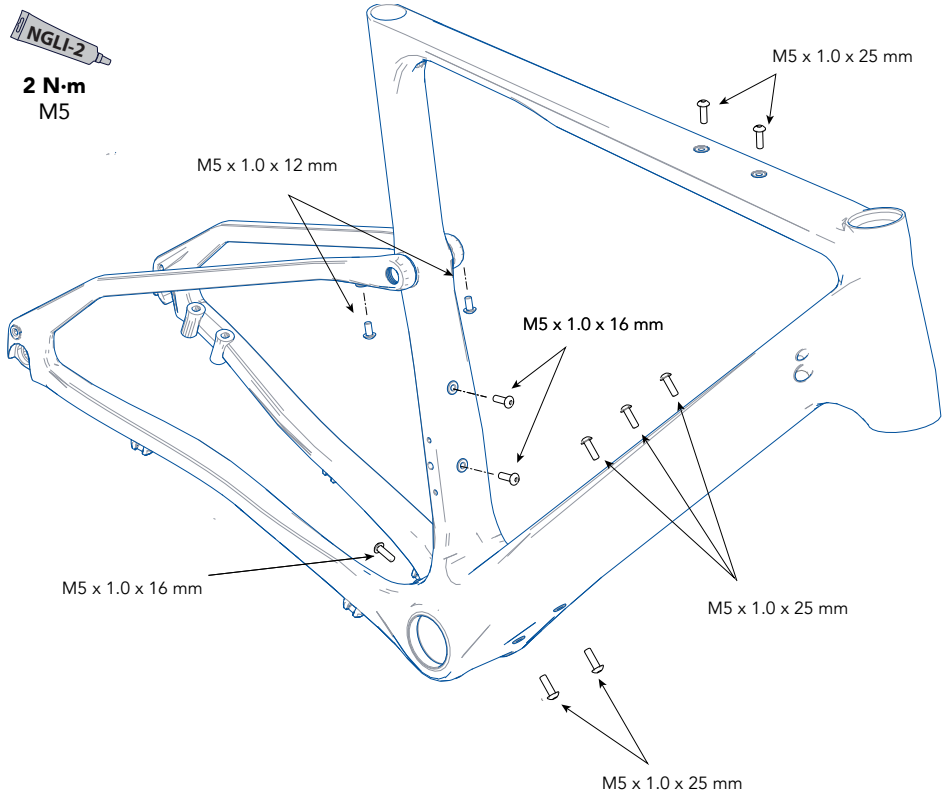

### NOTICE

- Do not use longer screws than the maximum lengths indicated at each location above.
- Clean screw threads and apply lightly grease to the threads before installation into the frame. Tighten to 2 N·m. Do not over-tighten the screws.
- See also "Water Bottles," page 4.

## REPLACEMENT PARTS

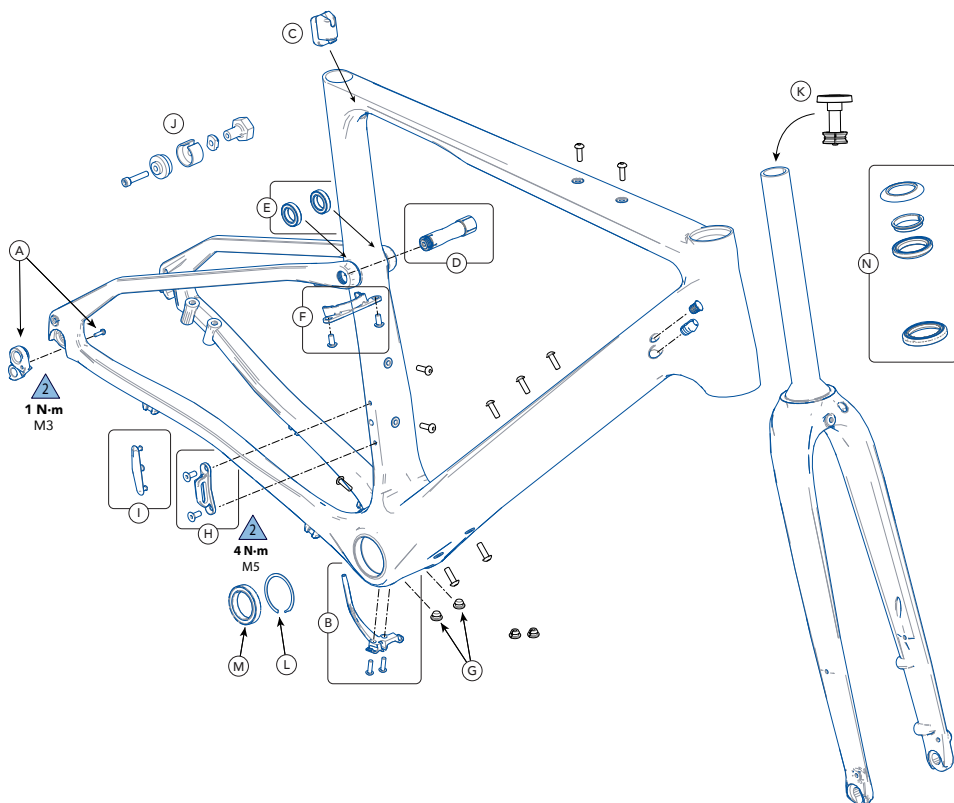

ID	Part Number	Description
A	K33009	Derailleur Hanger TA ST SS 070 *Double Lead
B	K32020	BB Cable Guide E256240
C	K26058	27.2 Internal Seat Binder
D	K91000	LockR Pivot Hardware 65mm
E	K36087	Pivot Bearing 6802 (QTY 2)
F	K11000	Topstone Crb Rear Fender Mount
G	K32079	Blank Frame Plugs (QTY 3)
H	K33000	Topstone Crb Front Derailleur Mount
I	K33010	Topstone Crb Front Derailleur 1X Cover
J	K91010	Kingpin Bearing Install Removal Tool

ID	Part Number	Description
K	K35009	SL Compression Plug with Top Cap
L	QC616/	Circlips (QTY-2)
M	KB6180/	BB30 Bearings
N	K35010	1-1/8-1.5 Int Hdset w/ 36 Deg CR 25/5 TC
--	K83010	Speed Rel TA 142x12 2Lead P1.0 Bolt 165L
--	K83000	Speed Rel TA 100x12 2Lead P1.0 Bolt 119L



WWW.CANNONDALE.COM

© 2019 Cycling Sports Group  
Topstone Owner's Manual Supplement  
134949 Rev. 2

**CANNONDALE USA**

Cycling Sports Group, Inc.  
1 Cannondale Way,  
Wilton CT, 06897, USA  
1-800-726-BIKE (2453)  
[www.cannondale.com](http://www.cannondale.com)

**CANNONDALE EUROPE**

Cycling Sports Group Europe, B.V.  
Mail: Postbus 5100  
Visits: Hanzeport 27  
7575 DB, Oldenzaal Netherlands

**CANNONDALE UK**

Cycling Sports Group  
Vantage Way, The Fulcrum,  
Poole, Dorset, BH12 4NU  
+44 (0)1202732288  
[sales@cyclingsportsgroup.co.uk](mailto:sales@cyclingsportsgroup.co.uk)