

Slice Carbon

CUTTING THE SEAT POST

The seat post will need to be cut to length for some riders. The reflector bracket works well for making a straight perpendicular.

Your shop may want to purchase the Park Tool SG-7 which works with most aero seat posts or aero seat tubes that require cutting. See <http://www.parktool.com/products/>.

1. Calculate the length to cut off and mark the seat post.

IMPORTANT: Measure twice cut once! Be sure that after your proposed cut is complete, the new length allows the minimum 80 mm of seat post length to be inserted into the seat tube.

Slide the reflector bracket to the mark and tighten the bracket very snug. FIGURE 1.

2. Using a fine tooth blade designed for carbon, carefully cut the seat post by hand. FIGURE 2.

When the cut is complete, lightly sand the edges of the cut with 240 grit sandpaper. FIGURE 3.

3. Use a permanent black ink marker to remove the original 'MIN INSERT' indication. FIGURE 4.

Measure 80 mm from the bottom of the cut post to mark a new 'MIN INSERT' line. Use a permanent marker or automotive marking tape to indicate

INSERTING THE SEAT POST

1. Apply carbon gel to the seat post and a little bit inside the seat tube.
2. Insert seat post into the frame without forcing it. In some frames (especially smaller sizes), a seat post will only be able to be inserted into a seat tube to a maximum depth of 100 mm. Below a depth of 100 mm carbon material can interfere with the seat post. The material can not be removed.
3. Tighten the seat binder to 6Nm.

WATER IN THE FRAME FROM THE SEAT POST

Any water that enters through the top of the seat post will exit through a drain hole that is already drilled in the bottom of the BB shell.



FIGURE 1



FIGURE 2

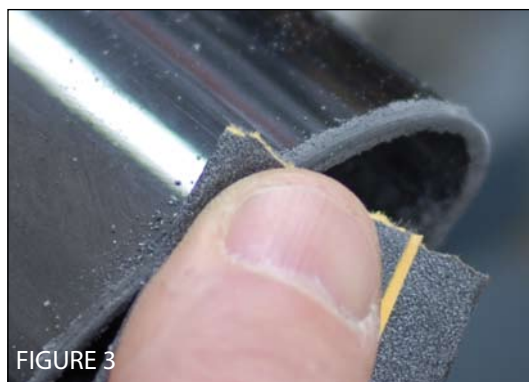

FIGURE 3

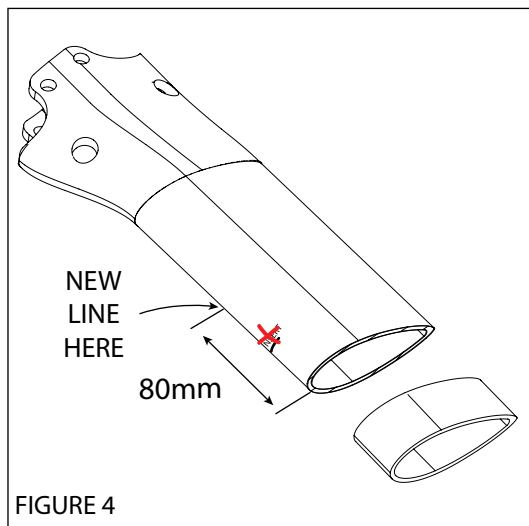
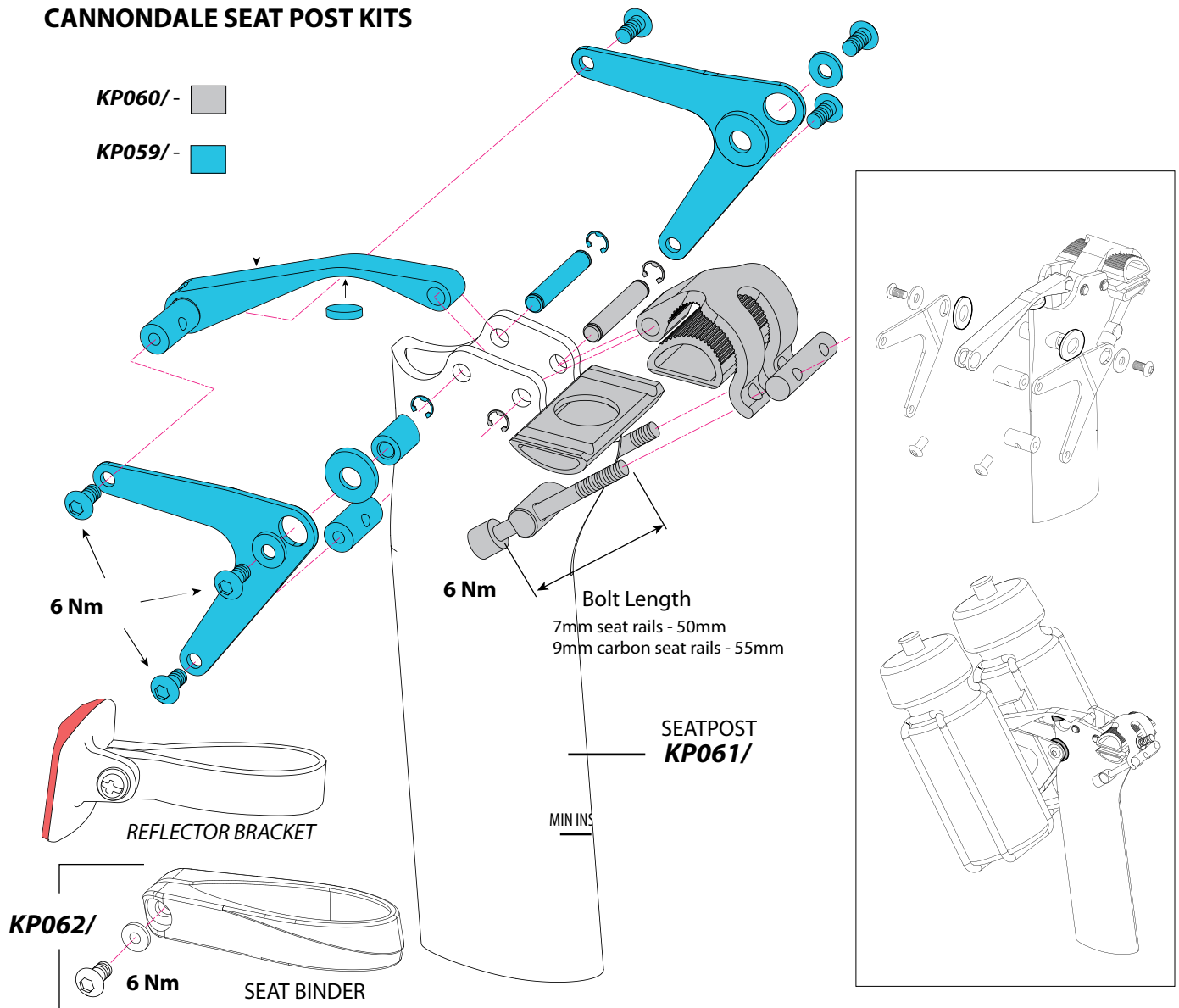

FIGURE 4

CANNONDALE SEAT POST KITS



SEAT POST CONFIGURATIONS

It does take some time to assemble but we wanted to have one post that could be used to achieve a 78-80 degree "triathlete position" or a 73-74 "roadie TT position".

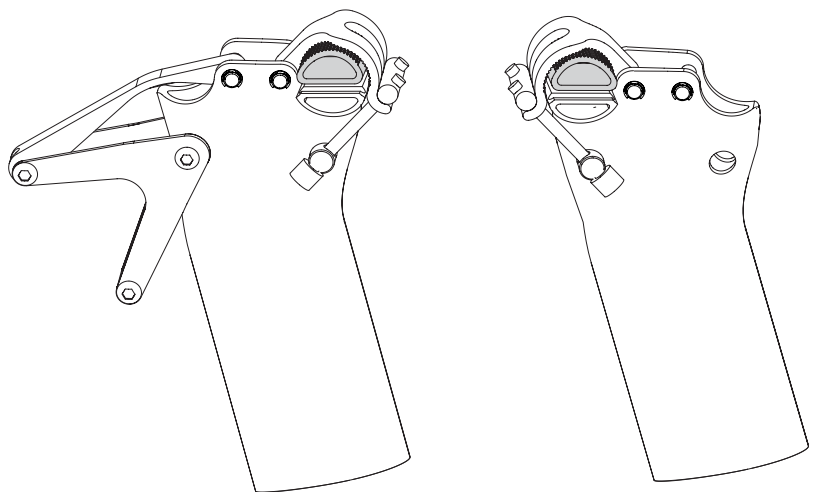

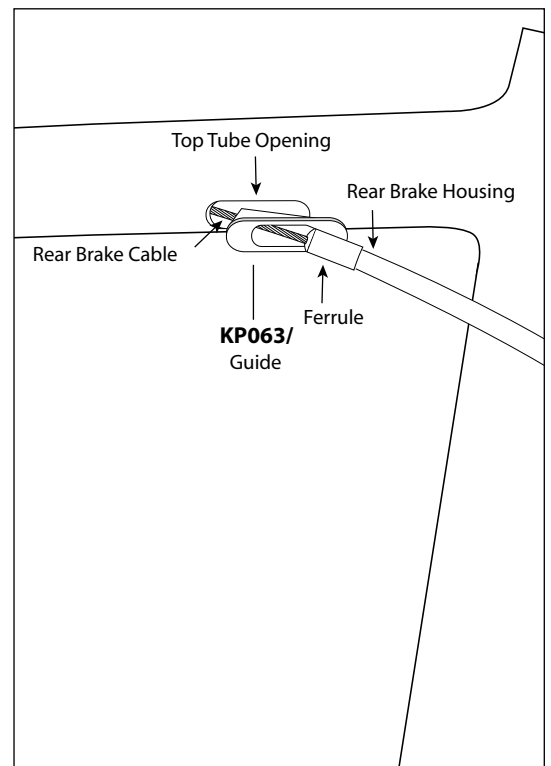
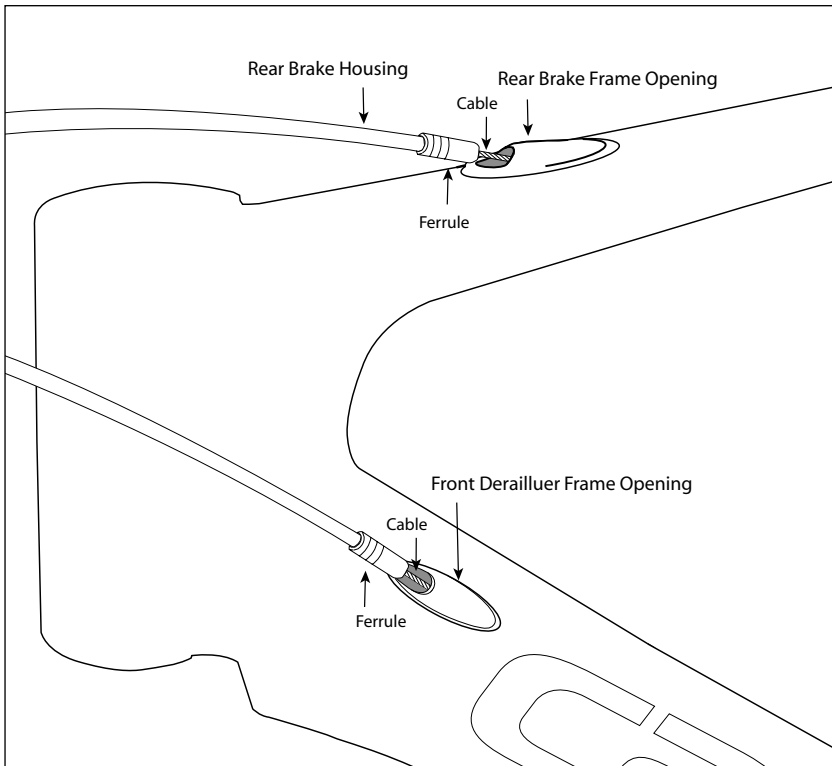
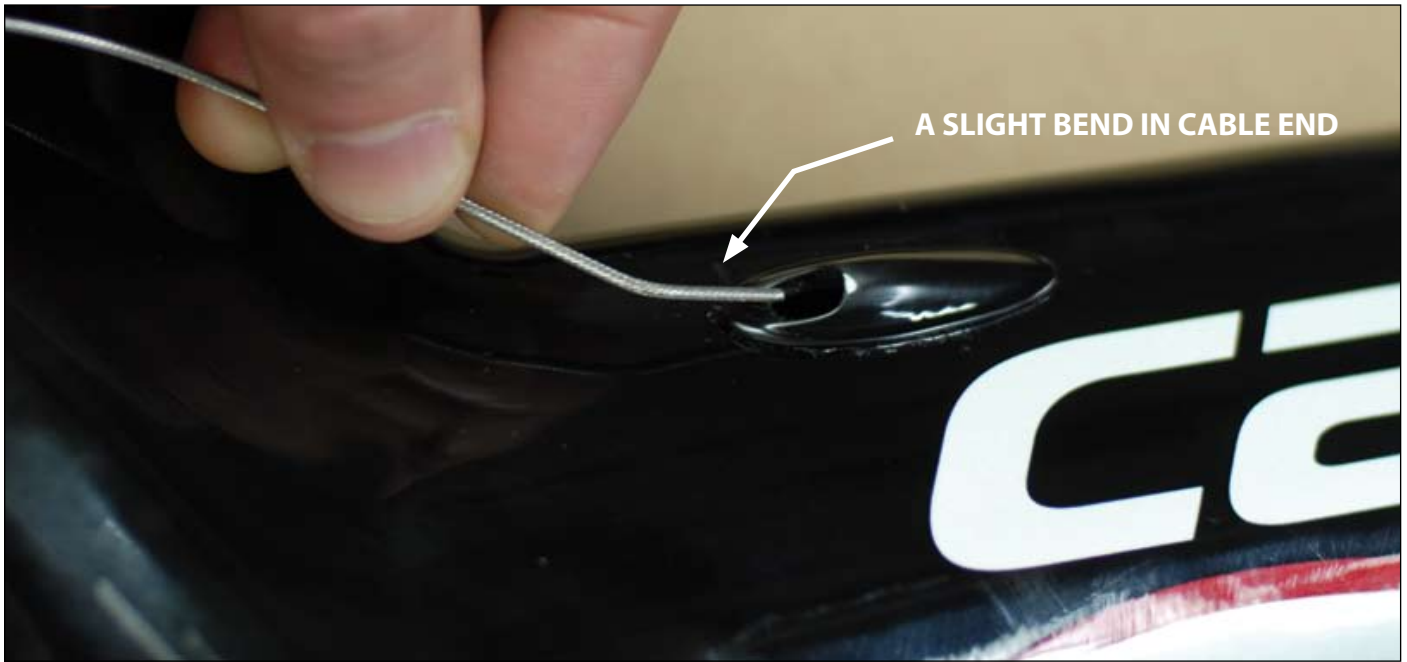

INTERNAL CABLE ROUTING

We made the decision that having internally routed cables was critical for an aero frame. The cable and housing ends enter the integrated cable stops and the bare cables run through the interior of the frame. Inside the frame, the pathways are large enough that cables can easily be fished through. The technique to get the bare cable through is an easy one.

Simply, make a small slight bend in the cable end before sending the cable through the cable stop housing in the frame. Feed in the cable, When cable encounters a edge inside the tube, that seems to stop it, just rotate the cable and push gently. The bend should pass easily. Cables will exit at the bottom of the bottom bracket.

