



CLAYMORE.
OWNER'S MANUAL SUPPLEMENT.

cannondale

CLAYMORE

OWNER'S MANUAL SUPPLEMENT

ENGLISH

ABOUT THIS SUPPLEMENT

Cannondale Owner's Manual Supplements provide important model specific safety, maintenance, and technical information. They are not replacements for your Cannondale Bicycle Owner's Manual.

This supplement may be one of several for your bike. Be sure to obtain and read all of them.

If you need a manual or supplement, or have a question about your bike, please contact your Cannondale Dealer immediately, or call us at one of the telephone numbers listed on the back cover of this manual.

You can download Adobe Acrobat PDF versions of any Cannondale Owner's Manuals or Supplements from our website: <http://www.cannondale.com/>.

YOUR CANNONDALE DEALER

To make sure your bike is serviced and maintained correctly, and that you protect applicable warranties, please coordinate all service and maintenance through your authorized Cannondale Dealer.

NOTICE

Unauthorized service, maintenance, or repair parts can result in serious damage and void your warranty.

SAFETY INFORMATION

INTENDED USE



The intended use of all models is ASTM CONDITION 4, OverMountain.

WARNING

UNDERSTAND YOUR BIKE AND ITS INTENDED USE. USING YOUR BIKE THE WRONG WAY IS DANGEROUS.

Please read your *Cannondale Bicycle Owner's Manual* for more information about Intended Use and Conditions 1-5.

CABLE ROUTING

Identification

1. Rear Derailleur
2. Front Derailleur
3. Rear Brake
4. Shock Remote
5. Seat Post Remote

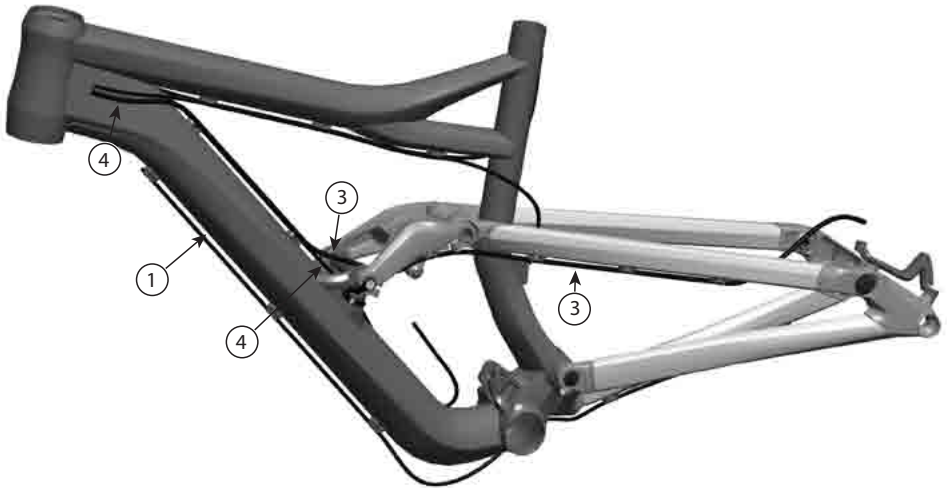
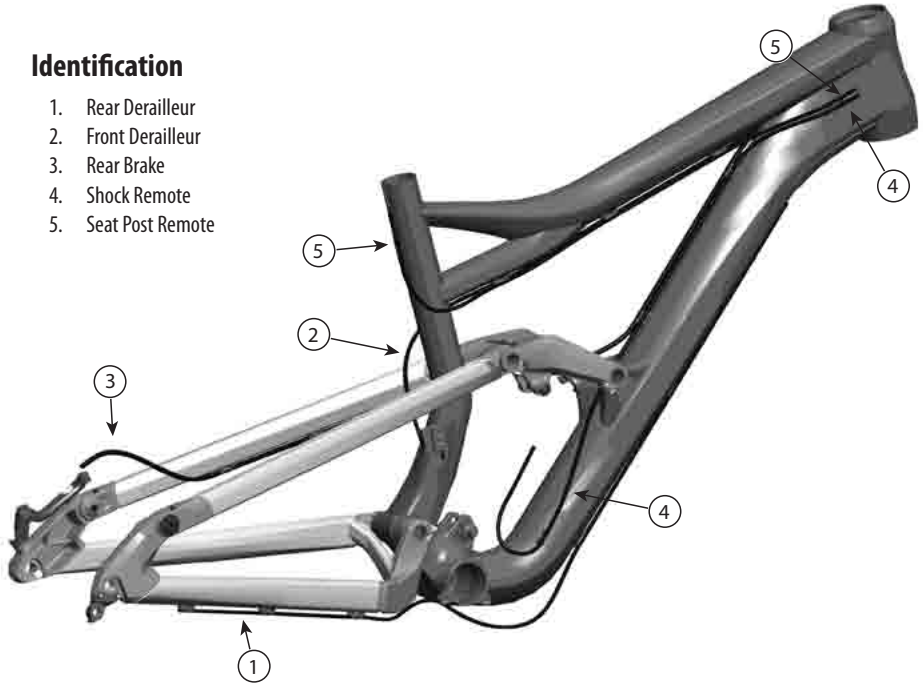

BOTTOM BRACKET

The bottom bracket shell is compatible with the BB30 Standard. See <http://www.bb30standard.com/>.

The SI bottom bracket adapter enables the use of standard English/73mm bottom bracket cranksets.

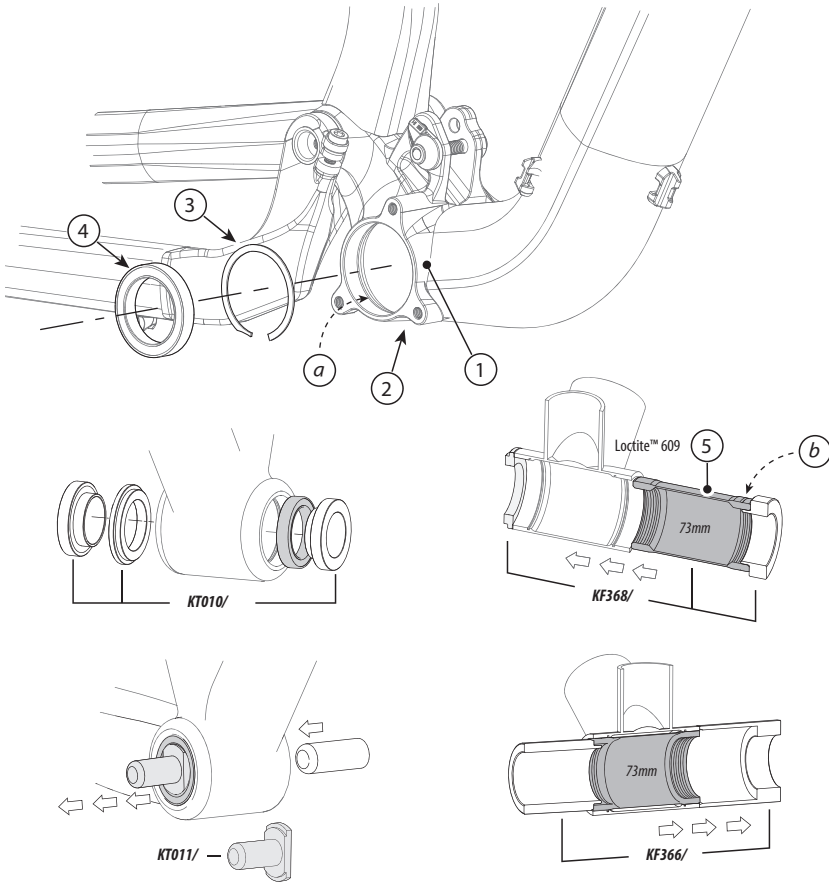

Identification

- | | |
|-------------------------|------------------------------|
| 1. Bottom Bracket Shell | a. Bb Circlip Groove |
| 2. ISCG03 Mount | b. Adapter Drive-Side Groove |
| 3. Circlip | |
| 4. Bearing | |
| 5. 73mm Adapter | |

Bearing Maintenance

Inspect bearing condition annually (at a minimum) and anytime the crankset assembly is disassembled or serviced. With the crankset removed, rotate the inner bearing race of both bearings; rotation should be smooth. No play or movement inside the shell. If the bearing is damaged, replace both bearings with new ones.

Bearing Removal/Installation (Professional Bike Mechanic Only)

Remove the old bearings with the bearing removal tool **KT011/**.

Reinstall bearings with a headset press and tool **KT010/**. Clean inside of shell apply a high-quality bicycle bearing grease to the inside surface. Press bearing one at a time. Press each bearing until seated against the circlip. Following installation, apply a light coating of a high-quality bicycle bearing grease to both sides of each bearing to help repel moisture.

TIP: *Unless a circlip is damaged, removal is unnecessary during bearing removal. Use a small thin-blade screw driver or pick to lift the hooked end up out of the groove and then pushing the circlip out counter-clockwise.*

Adapter Removal/Installation (Professional Bike Mechanic Only)

To install, first remove the bearings and circlips and clean the inside of the BB shell and adapter. Use a clean lint-free shop towel dampened with alcohol. Apply Loctite™ 609 carefully to the bearing seat positions to both shell and adapter. Install the adapter with a headset press and the installation tool **KF368/**. Adapter groove must be located on the BB drive side. Press until the groove side face is flush with the drive side face of shell. Allow at least 12 hours (at 72°F) for the Loctite to cure before installing the standard bottom bracket crankset. Follow Loctite Technical Data Sheet <http://tds.loctite.com/tds5/docs/609-EN.PDF>

To remove, use tool **KF366/** with a headset bearing press with tool arrangement as shown. Following removal, it will be necessary to clean all remaining Loctite residue with a before reinstalling the Si circlips and bearings. Use Loctite 768. Use a dental pick to remove any adhesive from the grooves. **For Loctite clean-up instructions :** <http://tds.loctite.com/>

NOTICE

BEARINGS - Frequent or routine renewal of undamaged bearings is not recommended. Repeated removal and reinstallation can damage the inside BB shell surfaces resulting in poor bearing fit. Do not face, mill or machine the bottom bracket shell for any reason. Doing so can result in serious damage and possibly a ruined bike frame.

ADAPTERS - Use only adapters/tool recommended by Cannondale. Other available adapters /tools may cause damage. See Replacement Parts. An adapter isn't a "repair" part, so the BB shell must be in good condition. Repeated removal and reinstallation of an adapter, or improper tools can cause damage. Therefore it is not recommended.

Loctite 609 - Prolonged contact with the frame finish may result in discoloration or damage. Be sure to immediately wipe up any spills and remove any compound in contact with the painted surfaces.

Do not cut, face, or use abrasives to clean the inside if the BB shell.

We strongly recommend that these procedures be performed by an Authorized Cannondale Dealer. Damage caused by improper installation/removal is not covered under your warranty.

SHOCK LINK

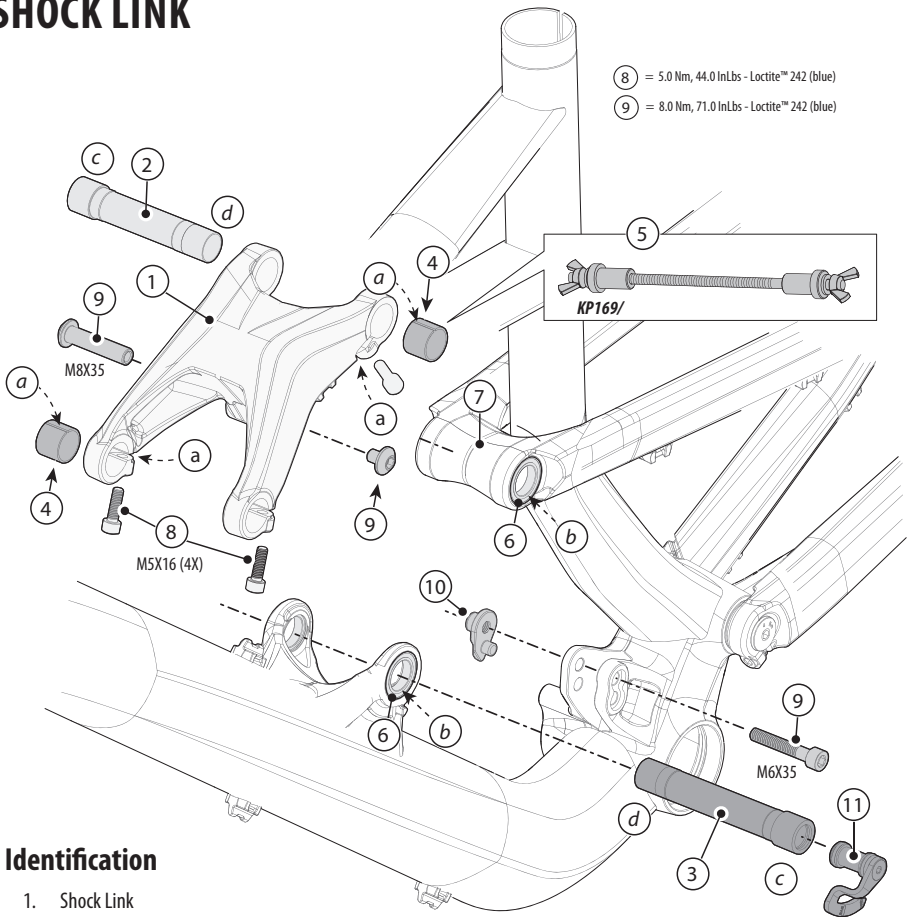

8 = 5.0 Nm, 44.0 InLbs - Loctite™ 242 (blue)

9 = 8.0 Nm, 71.0 InLbs - Loctite™ 242 (blue)

Identification

1. Shock Link
2. SS Lever Axle
3. DT Link Axle
4. Main Shim
5. Link Tool (inc. KP169/)
6. Bearing (61802-2RS, 15X24X5)
7. Seat Stay
8. Pinch bolts
9. Shock Mounting Bolt
10. Gemini Nut
11. SAG Indicator
- a. gap
- b. bearing inner race
- c. large end
- d. small end

Be sure to loosen the pinch bolts of link before assembly.

Before assembly, inspect all bearings for good condition. Replace if necessary.

Clean and apply Loctite 242 (blue) to the pinch bolt threads.
Tighten to 5 Nm, 44 InLbs.

Clean and apply light grease to pivot axles and main shims.

Insert DT Link Axle and SS Lever axles from opposites side of the link as shown.

Route cables correctly around pivot. See **Cable Routing**.

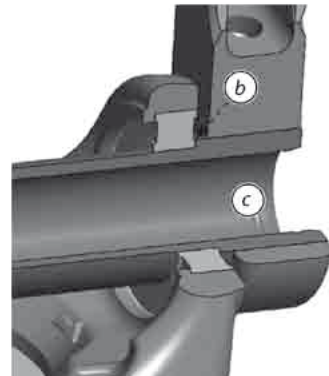
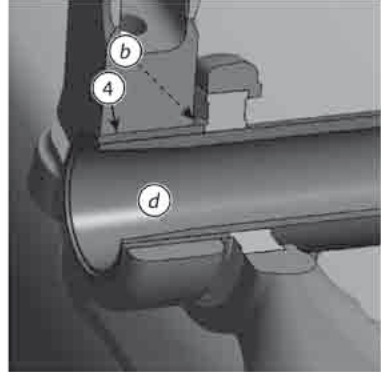
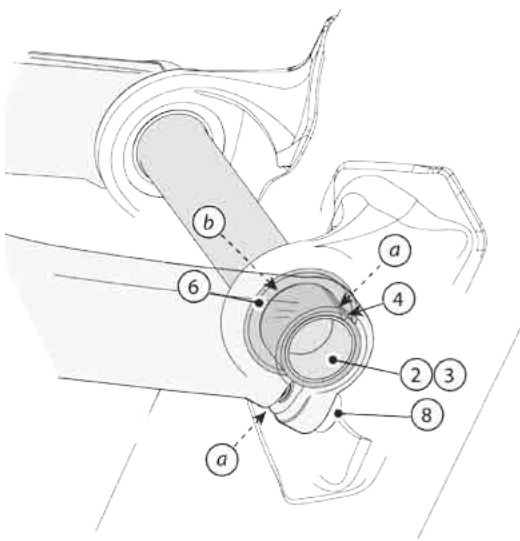

NOTICE

Incorrect assembly (pivot/shim) can result in linkage play, accelerated wear, or damage.

Do not over-tighten. Use a torque wrench.



Use **KP169/to** press link pivot axles and main shim together as shown. Before tightening pinch bolts, make sure both the shim and axle are seated against the bearing inner race (upper), and the gaps (arrows) between bearing and link arm should be the same on each side. You can center the link easily shifting it left or right to do it before the bolts are tightened.

Using the Sag Indicator

The sag indicator is inserted in the left side of the bike in the downtube pivot axle.

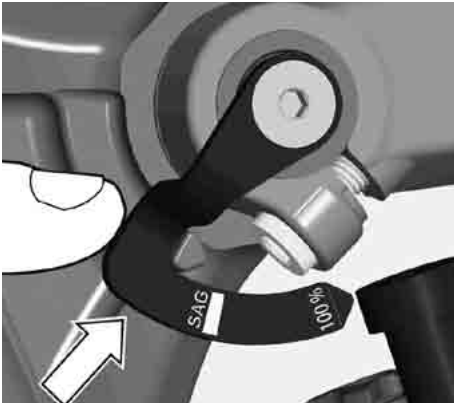

1. Set air pressure. See page 16.
2. Rotate the sag arm to the frame stop, shown above.
3. Sit on saddle, feet on pedals in riding position.

4. Dismount. Check arm travel. If the recommended sag 33-40% sag is present the "SAG" bar will be at the frame stop. See above.



If the arm rotates further beyond the "SAG" mark toward the "100%" mark, it is telling you that more than 33-40% sag is present. See above. For more sag, move down a row in the air pressure chart. For less sag, move up a row.



The sag indicator assembly can be removed from the downtube pivot by simply pulling it out.

Changing Shock Position/Bottom Bracket Height

The height of the bottom bracket is changed by the attachment position of the rear shock to the frame. See the **Geometry** section in this supplement for the resulting change when the lower shock bolt is in the HI or LO position.

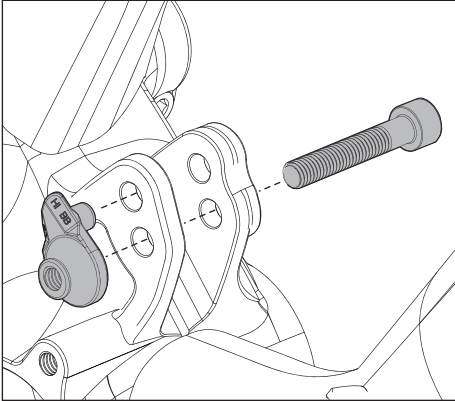

Position the nut like this to raise the bottom bracket.

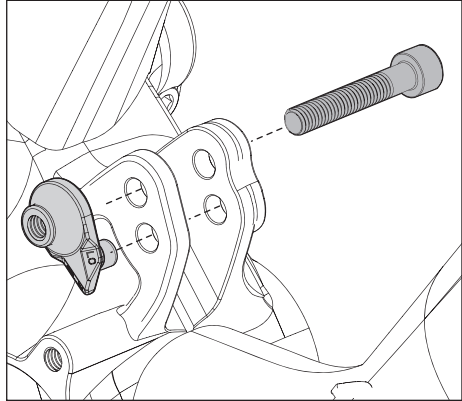

Position the nut like this to lower the bottom bracket.

MAIN PIVOT

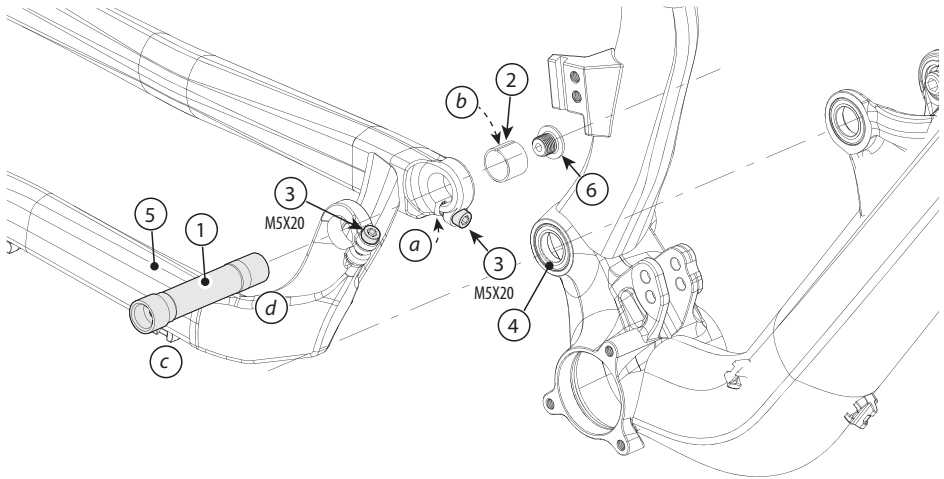

Identification

- | | |
|---------------------------------|-----------------------|
| 1. Main Pivot Axle | 6. Main Pivot Screw |
| 2. Main Shim | a. gap |
| 3. Pinch bolts | b. bearing inner race |
| 4. Bearing (61802-2RS, 15X24X5) | c. large end |
| 5. Chainstay | d. small end |

Always loosen the pinch bolts first.

Before assembly, inspect all bearings for good condition. Replace if necessary.

Always clean and apply Loctite 242 (blue) to the pinch bolt threads.

Always tighten with a torque wrench to 5 Nm, 44 InLbs.

NOTICE

Incorrect installation shims can result in play in the linkage and accelerate wear or damage.

Do not over-tighten the pinch bolts.

DROPOUT

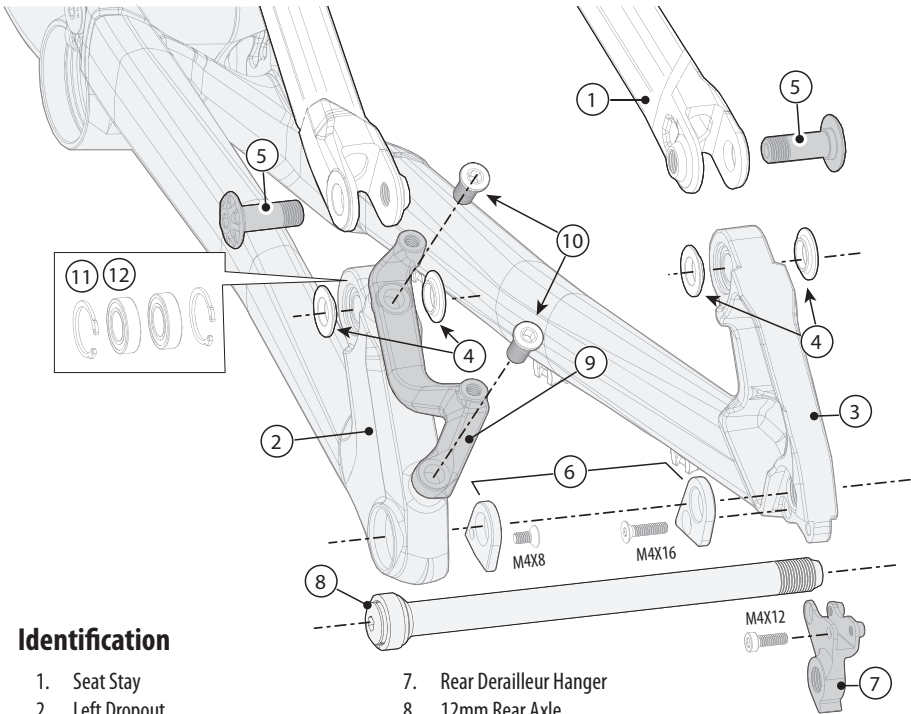

Identification

- | | |
|----------------------|---------------------------|
| 1. Seat Stay | 7. Rear Derailleur Hanger |
| 2. Left Dropout | 8. 12mm Rear Axle |
| 3. Right Dropout | 9. Brake Adapter(s) |
| 4. Pivot Spacers | 10. Chainring Bolts 16mm |
| 5. Pivot Axle Bolts | 11. Circlip |
| 6. 135mm Hub Spacers | 12. Bearing |

Before attachment, inspect the bearings to make sure they are in good condition.

Check the seat stay If the bearings are damaged, remove them and replace them with new ones.

Always insert small end of pivot spacers into the bearings. The flat side of the spacers face out.

Always insert a 5mm hex key completely into the axle bolts to prevent damage when turning the bolt.

Always tighten with a torque wrench to the specified torque.

Install the hub spacers for 135mm spacing, remove for 142mm hub spacing.

GEOMETRY / SPECIFICATION

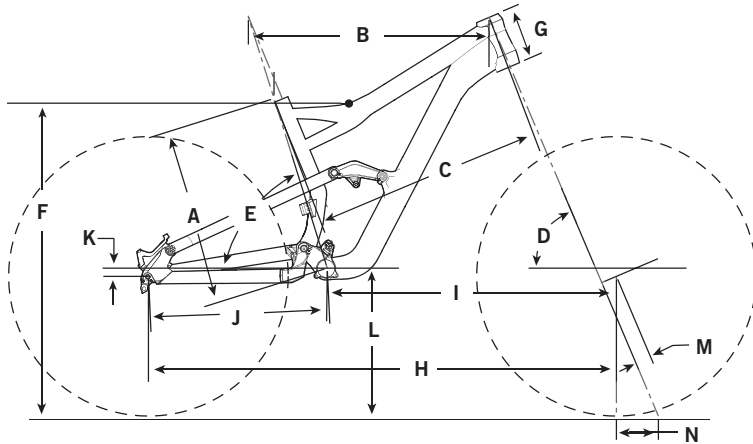

CLAYMORE

Geometry

	SMALL	MEDIUM	LARGE	X-LARGE	
A	Seat Tube Length (cm/in)	39.5/15.6	43.0/16.9	47.0/18.5	51.0/20.1
B	Top Tube Horizontal (cm/in)	54.9/21.6	58.2/22.9	61.1/24.1	64.3/25.3
C	Top Tube Actual (cm/in)	52.9/20.8	55.6/21.9	58.2/22.9	61.3/24.1
D	Head Tube Angle Hi BB	66.5°	67.0°	★	★
D	Head Tube Angle Lo BB	65.5°	66.0°	★	★
E	Seat Tube Angle Effective	73.0°	72.6°	72.1°	71.8°
F	Standover Hi BB (cm/in)	73.7/29.0	75.6/29.8	78.2/30.8	80.7/31.8
F	Standover Lo BB (cm/in)	72.6/28.6	74.5/29.8	77.1/30.3	79.6/31.3
G	Head Tube Length - (cm/in)	11.5/4.5	13.0/5.1	14.0/5.5	15.0/5.9
H	Wheelbase (cm/in)	110.9/43.7	113.2/44.6	115.7/45.6	118.5/46.7
I	Front Center (cm/in)	67.6/26.6	69.9/27.5	72.4/28.5	75.2/29.6
J	Chain Stay Length (cm/in)	43.3/17.0	★	★	★
K	Bottom Bracket Drop Hi BB (cm/in)	2.0/0.8	★	★	★
K	Bottom Bracket Drop Lo BB (cm/in)	0.8/0.3	★	★	★
L	Bottom Bracket Height Hi BB (cm/in)	35.8/14.1	★	★	★
L	Bottom Bracket Height Lo BB (cm/in)	34.6/13.6	★	★	★
M	Fork Rake (cm/in)	3.9/1.5	★	★	★
N	Trail (cm/in)	10.5/4.1	10.2/4.0	10.2/4.0	10.2/4.0

Please note that the specifications and information in this manual are subject to change for product improvement.

For the latest product information, go to <http://www.cannondale.com/>

Specifications

Frame Types	SmartFormed Alloy
Headtube	Integrated SI
Chainline	50 mm
BB Shell Width	BB30 73 mm
Rear Travel Modes (remote lever selectable)	FLOW - 180 mm ELEVATE - 110 mm
Rear Shock	FOX DYAD RT2 Pull Shock
Seat Post Diameter	Use a seat post with a 31.6 mm diameter only. Do not use other size seatposts. Do not use a seat post with a shim or adapter.
Front Derailleur	Shimano Direct Mount
Dropout Spacing	142mm (convertible to 135mm)
Rear Brake	Post Mount Adapters - 160/180/185/203



WARNING

Please read your *Cannondale Bicycle Owner's Manual* for more information on the following specifications:

Intended Use	ASTM Condition 4, All-Mountain OverMountain
Maximum Tire Width	2.5"
Maximum Fork Length	570 mm
Minimum Seat Post Insert	100 mm

Tightening Torques

Correct tightening torque for the fasteners (bolts, screws, nuts) on your bicycle is very important to your safety. The durability and performance of your bicycle. We urge you to have your Dealer correctly torque all fasteners using a torque wrench. If you decide to tighten fasteners yourself always use a good torque wrench!

DESCRIPTION	Nm	In Lbs	Loctite™
Rear Brake Adapter (Maximum)	10.0	88.5	242 (blue)
Shock Mounting Bolts	8.0	71.0	
Dropout Pivot Axle Bolts	7.0	62.0	
Shock Link Pinch Bolts	5.0	44.0	
Main Pivot Pinch Bolts			
Rear Derailleur Hangar Screws	2.5	22.0	

FOX DYAD RT2 PULL SHOCK

The DYAD RT2 rear shock was engineered and manufactured by Fox Racing Shocks in collaboration with Cannondale. This supplement includes safety information, and instructions on how to set-up and operate the shock in the frame. For the manufacturer's specific maintenance and service instructions, you must go to the Fox Racing Shox original equipment (OE) custom products website. Go to http://www.foxracingshox.com/fox_tech_center/owners_manuals/09/custprod/index.html

Identification

1. ELEVATE - 110 mm Rebound
2. FLOW - 180 mm Rebound
3. Negative Air Valve
4. Positive Air Valve
5. Valve Cap
6. Long Travel Chamber
7. Short Travel Chamber
8. Spool Chamber
9. Spool Chamber End Caps
10. Fixed Eyelet
11. Shaft Eyelet
12. Cable Anchor
13. Cable Set Screw
14. Remote Lever Cable
15. Cable End Cap
16. Ferrule
17. Remote Lever Cable Housing
18. Bridge
19. Bushing
20. Reducer

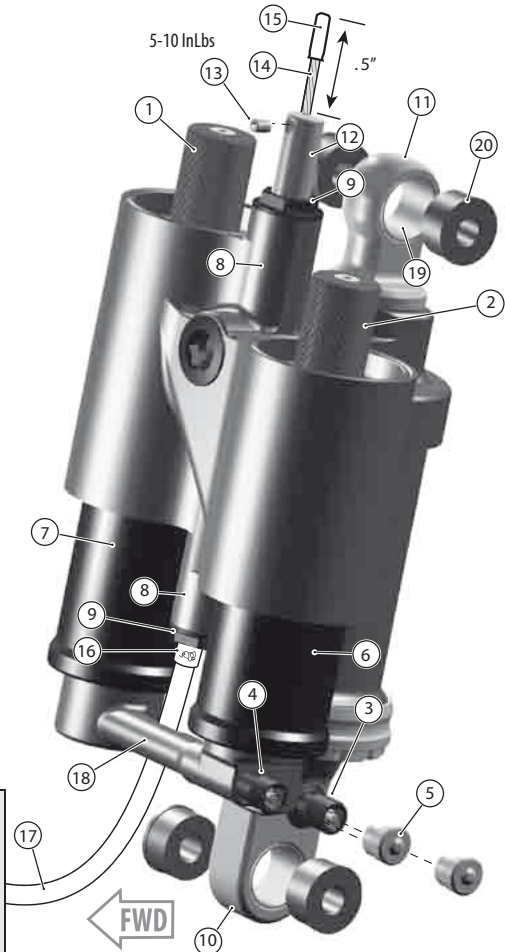

NOTICE

Wash with soap and water only. Never use a high pressure washer to clean.

Mount shock as shown in photo, next page. Do not mount shock in a different position. Severe damage to the frame, link, or shock can result.

Maintenance & Service Information

WARNINGS

HIGH-PRESSURE HAZARD - Do not open, disassemble, modify, or attempt to perform internal service to the shock. The DYAD RT2 shock is not user serviceable. Never attempt to remove the spool chamber end caps for any reason! Attempting to perform any mechanical service procedure on this shock can potentially result in serious injury or death. Remote lever cable installation must be performed by a professional bike mechanic.

All service and repair must only be performed by FOX Racing Shox or an FOX Authorized Service Center.

For more information contact: <http://www.foxracingshox.com/fox/contact>

Frame Installation

Please note that the DYAD RT2 is to be mounted only in the frame in the position shown below.

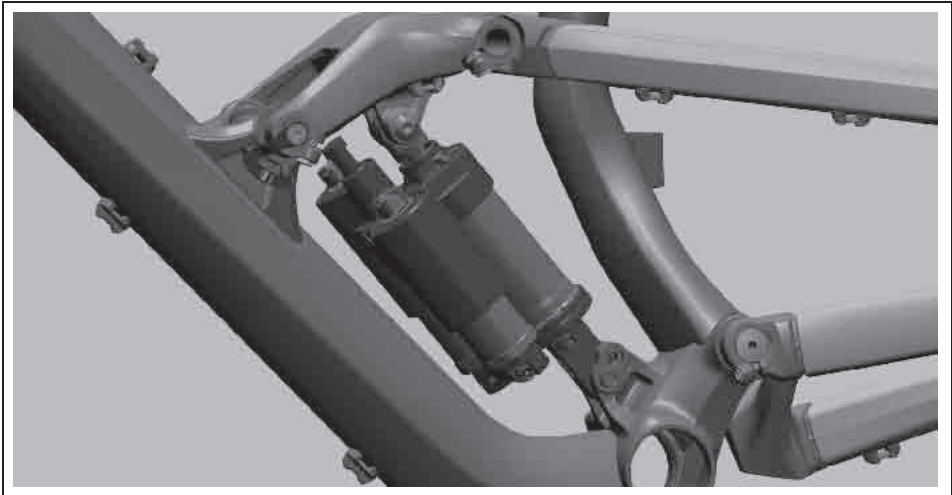

Pre-Ride Checks

1. Clean the outside of your shock with soap and water and wipe dry with a soft dry rag. Inspect the entire exterior of the shock. **DO NOT RIDE THE SHOCK IF YOU FIND DAMAGE.** Please contact FOX Racing Shox for further inspection and repair.
2. Set Sag. See **Setting Sag**.
3. Set Rebound. See **Setting Rebound**.

Setting Sag:

1. **Set shock to the FLOW - 180 mm (long travel) mode with the remote lever.** In this mode, the sag you set will be 100%. When the DYAD RT2 is switched to the ELEVATE - 110mm mode, the sag is automatically reduced to 60%.

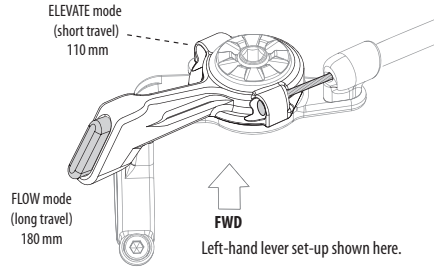

2. **Remove  negative air valve cap.**

Connect the pump (Cannondale 1MP01/SLV) to the negative air pressure valve, press and hold the release button to release all air pressure.
Replace the valve cap.



4. **Remove  positive air valve cap. Attach the pump to positive air valve.**
Set positive air pressure for your weight according to the **DYAD RT2 Recommended Air Pressure** table.
Replace the valve cap.



5. **Again, attach pump to  negative air chamber valve and set negative air pressure for same weight.** Replace the valve cap.

After setting sag, you find that you want more or less sag, choose the next lighter or heavier rider weight range from the table. Repeat steps 1-5 again.



Recommended Air Pressure

DYAD RT2 shock sag best performance range is 33%-40% of total travel. The table below contains values for this target range. After setting sag, you find that you want more or less sag, choose the next lighter or heavier rider weight range from the table. Repeat Sag Setting steps 1-5 again.

TOTAL RIDER WEIGHT		AIR PRESSURE			
		⊕ POSITIVE AIR VALVE		⊖ NEGATIVE AIR VALVE	
<i>lbs</i>	<i>kg</i>	<i>psi</i>	<i>bar</i>	<i>psi</i>	<i>bar</i>
100 - 109	45 - 49	188	13.0	159	11.0
110 - 119	50 - 54	207	14.3	175	12.0
120 - 129	54 - 59	226	15.6	191	13.1
130 - 139	59 - 63	245	16.9	206	14.2
140 - 149	64 - 68	264	18.2	222	15.3
150 - 159	68 - 72	282	19.5	238	16.4
160 - 169	73 - 77	301	20.8	254	17.5
170 - 179	77 - 81	320	22.1	270	18.6
180 - 189	82 - 86	339	23.4	286	19.7
190 - 199	86 - 90	358	24.7	302	20.8
200 - 209	91 - 95	376	26.0	318	21.9
210 - 219	95 - 99	395	27.3	334	23.0
220 - 229	100 - 104	414	28.6	349	24.1
230 - 239	104 - 108	433	29.8	365	25.2
240 - 249	109 - 113	450	31.1	381	26.3
LOW PRESSURE LIMITS:		100	6.9	0	0
HIGH PRESSURE LIMITS:		450	31.1	400	27.6

NOTICE

TO PREVENT DAMAGE TO THE SHOCK: 1. Follow the setting sag step in order. 2. Follow/maintain high and low pressure limits. 3. Make sure the suspension pump and DYAD RT2 valves are clean before attachment.



WARNINGS

USE ONLY HIGH-PRESSURE AIR PUMP - CANNONDALE - 1MP01/SLV TO SET OR READ PRESSURE Use of an incompatible pump (one not designed for the high pressure range of the shock), can result serious personal injury or result in an improper pressure setting or reading which can contribute to a loss of rider control and accident.

Disconnecting the pump results in very small pressure loss. To determine actual loss for your pump, set pressure, disconnect and reconnect. You can compensate by adding the loss to the table values.

Setting Rebound

Rebound controls the rate at which your rear wheel returns after it has been compressed. The proper rebound setting is of personal preference, and varies with rider weight, riding style and conditions. A basic rule of thumb is to set rebound to be as quick as possible, without kicking back and pushing you off the saddle.

To set rebound :

1. The rebound circuits work independently. Make sure the remote travel lever is set to the travel mode you're setting. See Setting Travel..
2. Turn the selected rebound knob clockwise until it stops. Turn it counter-clockwise; counting each click. A good starting point to begin adjustments is 7 clicks out from closed. Each rebound dial has about 13 clicks of adjustment range.

ELEVATE 110 mm



FLOW 180 mm



NOTICE

Do not force rebound dial past stop point.



WARNING

KEEP HANDS AND FINGERS AWAY FROM MOVING LINKAGE. Make adjustments when you are off the saddle, not riding or sitting on bike. Attempting to adjust rebound while sitting or riding in motion on your bicycle can lead to a serious hand/finger injury or a loss of rider control, which can result in serious injury or death.

Setting Travel

The DYAD RT2 has two travel modes, activated by the remote handlebar-mounted lever. Switching between the modes changes the bike's sag and BB height, offering a higher BB and steeper angles for climbing, or a lower BB and slacker angles for descending, keeping the rider in the proper position for the terrain. It is fundamentally like having two different bikes available to you at the flick of a switch.

To operate remote lever :

Push the lever forward until it clicks into place in the ELEVATE 110 mm position.

Press the lever button to release the lever and allow cable tension to return the lever to the FLOW 180 mm position.

ELEVATE 110 mm



A (short travel) mode with low volume air shock for providing a firm, progressive spring rate, XC type damping circuits for trail riding, rolling terrain, and climbing performance.

Spring Rate is Steeper

Sag is cut to 60%

BB is higher / Steep Geometry

FLOW 180 mm



DYAD RT2's L.A.S. (linear airspring technology) provides a spring rate that is virtually identical to a coil spring and mates it with speed sensitive DH style damping circuits tuned for maximum descending performance.

Spring rate is softer.

Sag is 100%

BB is lower / Stable Geometry

Remote Cable Installation

Attach remote cable with shock unmounted from frame.

1. Place bike in a work stand with the rear wheel supported so the linkage does not move and the shock can be positioned and reconnected.
2. Determine cable housing length. Allow sufficient slack for proper shock operation and full handlebar steering rotation. Too much housing can interfere with moving frame parts.
3. Install ferrules at both ends of the cable housing.
4. Set lever to FLOW - 180mm mode. Insert a new derailleur cable (1.2 mm) into lever, housing end through to the shock end.
5. Feed housing/cable under shock bridge, and into the bottom of the shock spool chamber, and out the shock cable anchor. Make sure that you have a new or cleanly snipped cable, or the anchor set screw is backed out far enough. Otherwise, you may have difficulty feeding the cable through the spool chamber and past the anchor set screw.

WARNING

HIGH PRESSURE HAZARD - Do not remove the spool chamber end caps for any reason! Very high-pressure can propel the end caps with extreme force and velocity, potentially resulting in serious injury or death.

6. Pulling the cable taut, tighten the cable anchor 1.5mm set screw firmly (5-10 in-lb torque).
7. Snip the cable 0.5" above the cable anchor, and cap it.



8. Install the Dyad RT2 back into the bicycle frame.
Clean the mounting bolt threads, apply Loctite 242 (blue) and tighten to 8.0 Nm, 71 InLbs.
9. Secure the housing to the DT frame guide.
10. Test the lever for normal operation between the 180mm and 110mm travel modes.

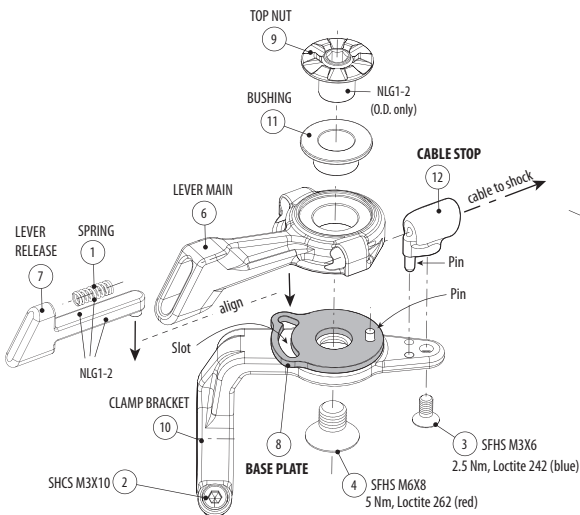

LEFT HANDLEBAR

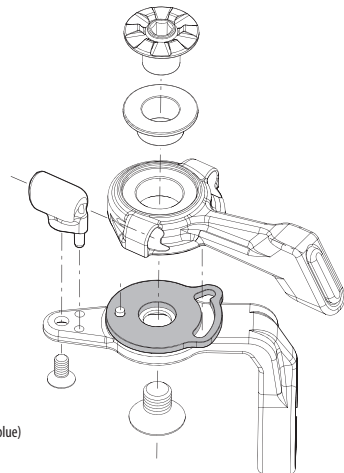

RIGHT HANDLEBAR

REPLACEMENT PARTS

The following replacement part kits are available through a Cannondale Dealer:

KP180/



KP202/ 1.5"

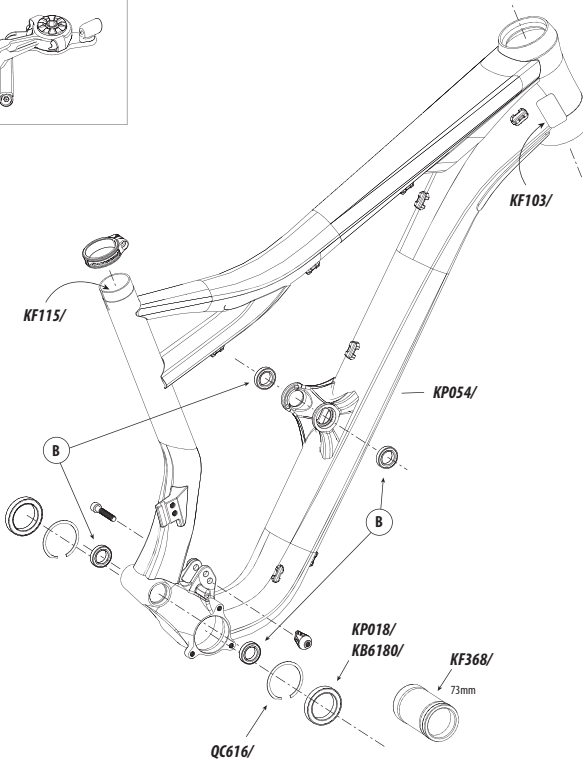
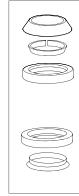

NO. (QTY)	KIT	DESCRIPTION
	KP170/BLK	KIT,SEATBINDER,MTN QR,34.9,BLK
	KP170/RED	KIT,SEATBINDER,MTN QR,34.9,RED
	KP180/	KIT,LEVER,TRAVEL ADJUST
	KP183/	KIT,ZIP TIES, CABLEGUIDE /25
	KP189/	KIT,GUIDE,HOUSING,BOLT-ON 3
	KP054/	KIT,GUARD,SCUFFGUARD,DWN TBE
	KF103/	KIT,GUARD,SCUFFGUARD-8PK

NO. (QTY)	KIT	DESCRIPTION
	KP202/	KIT,HEADSET,INT HSHOK TO 1.5
	KP018/	KIT,BEARING,BB-SI,CERAMIC,2PCS
	KB6180/	KIT,BEARING,BB-SI,2PCS
	QC616/	KIT,CIRCLIPS (2) BB-SI
	KP010/	KIT,ADAPTER,SIBB TO 73MM TAP
	KF368/	KIT,TOOL,SIBB/73 ADP.INSTALL
	KF366/	KIT,TOOL,SIBB ADAPTER EXTRACT

KP169/

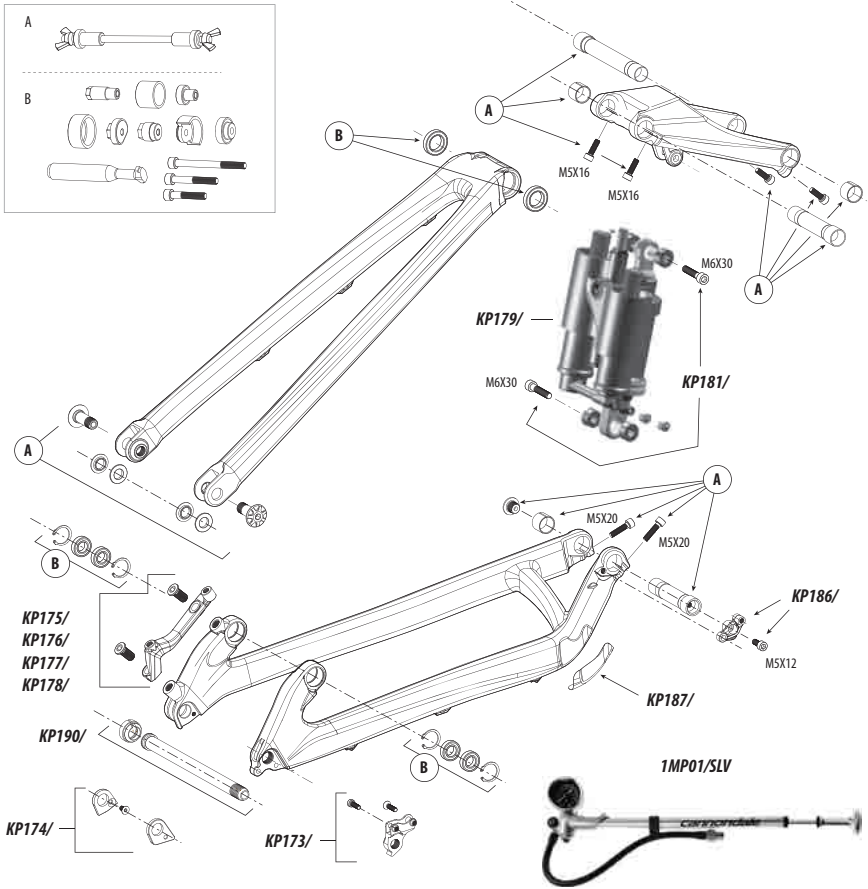

NO. (QTY)	KIT	DESCRIPTION
	KP173/	KIT, DER. HANGER, SI12
	KP174/	KIT, SPACER, SI12, 142 TO 135MM
	KP175/	KIT, ADAPTER, SI12 PM/160
	KP176/	KIT, ADAPTER, SI12 PM/180
	KP177/	KIT, ADAPTER, SI12 PM/185
	KP178/	KIT, ADAPTER, SI12 PM/203
	KP190/	KIT, AXLE, SYNTACE, X12, 142X12MM

NO. (QTY)	KIT	DESCRIPTION
	KP198/	KIT, SHOCK, CLAYMORE DYAD RT2
	KP199/	KIT, SHOCK MOUNT HWARE, CLAYMORE
A	KP201/	KIT, LINK, HWARE, CLAYMORE --- BEARINGS SOLD SEPERATELY---
B	KP185/	KIT, BEARINGS, PIVOT, JEKYLL W/ CIR-CLIPS
	1MP01/SLV	KIT, PUMP, HP DYAD RT2
	KP169/	KIT, TOOL, JEKYLL PIVOT

MAINTENANCE

The following table lists only supplemental maintenance items. Please consult your Cannondale Bicycle Owner's Manual for more information on basic bike maintenance. Consult with your Cannondale Dealer to create a complete maintenance program for your riding style, components, and conditions of use. Follow the maintenance recommendations given by the component manufacturers for the various non-Cannondale parts of your bike.

ITEM	FREQUENCY
<p>HOUSING AND CABLES - Your bike has been supplied with small adhesive frame protectors. Place this material on the the frame between where cables and housing rub due to movement. Overtime, cable rubbing can wear into the frame itself causing very serious frame damage.</p> <p>NOTE: <i>Damage to your bike caused by cable rubbing is not a condition covered under your warranty. Also, adhesive frame guards are not a fix for incorrectly installed or routed cables or lines. If you find that applied guards are wearing out very quickly, consult with your Cannondale Dealer about the routing on your bike.</i></p>	BEFORE FIRST RIDE
<p>DAMAGE INSPECTION Clean and visually inspect entire bike frame/swingarm/linkage assembly for cracks or damage. See "Inspect For Safety" in your Cannondale Bicycle Owner's Manual.</p>	BEFORE AND AFTER EACH RIDE
<p>CHECK TIGHTENING TORQUES - In addition to other component specific tightening torques for your bike. Tighten according to the TIGHTENING TORQUES information listed in this supplement.</p>	EVERY FEW RIDES
<p>CHAIN PLATE - Replace this protector if it becomes damaged. See Replacement Parts, KP187/.</p>	
<p>INSPECT BEARINGS, REPLACE WORN OR DAMAGED PARTS :</p> <ul style="list-style-type: none"> • SHOCK LINK ASSEMBLY • SEAT STAY • DROPOUT PIVOT • CHAIN STAY • FRAME 	<p>IN WET, MUDDY, SANDY CONDITIONS EVERY 25 HRS.</p> <p>IN DRY, CONDITIONS EVERY 50 HRS.</p>
<p>FORK - Please consult the manufacturer's owner's manual for maintenance information for your fork .</p>	
<p>DYAD RT2 Rear Pull Shock - See page 14.</p>	



WARNING

ANY PART OF A POORLY MAINTAINED BIKE CAN BREAK OR MALFUNCTION LEADING TO AN ACCIDENT WHERE YOU CAN BE KILLED, SEVERELY INJURED OR PARALYZED. Please ask your Cannondale Dealer to help you develop a complete maintenance program, a program which includes a list of the parts on your bike for YOU to check regularly. Frequent checks are necessary to identify the problems that can lead to an accident.



WARNING

READ THIS SUPPLEMENT AND YOUR CANNONDALE BICYCLE OWNER'S MANUAL.
Both contain important safety information. Keep both for future reference.

cannondale

CANNONDALE USA

Cycling Sports Group, Inc.
172 Friendship Road,
Bedford, Pennsylvania, 15522-6600, USA
(Voice): 1-800-BIKE-USA
(Fax): 814-623-6173
custserv@cyclingsportsgroup.com

CANNONDALE EUROPE

Cycling Sports Group Europe, B.V.
mail: Postbus 5100
visits: Hanzepoort 27
7570 GC, Oldenzaal, Netherlands
(Voice): +41 61.4879380
(Fax): 31-5415-14240
servicedeskeurope@cyclingsportsgroup.com

CANNONDALE UK

Cycling Sports Group
Vantage Way, The Fulcrum,
Poole, Dorset, BH12 4NU
(Voice): +44 (0)1202 732288
(Fax): +44 (0)1202 723366
sales@cyclingsportsgroup.co.uk

CANNONDALE AUSTRALIA

Cycling Sports Group
Unit 8, 31-41 Bridge Road
Stanmore NSW 2048
Phone: +61 (0)2 8595 4444
Fax: +61 (0) 8595 4499
askus@cyclingsportsgroup.com.au

CANNONDALE JAPAN

Namba Sumiso Building 9F,
4-19, Minami Horie 1-chome,
Nishi-ku, Osaka 550-0015, Japan
(Voice): 06-6110-9390
(Fax): 06-6110-9361
cjcustserv@cannondale.com

WWW.CANNONDALE.COM

© 2011 Cycling Sports Group
126585 (03/11)